

Features

- Output Current up to 0.5A
- Output Voltages of 5, 6, 8, 9, 12, 15, 18, 24V
- Thermal Overload Protection Short Circuit Protection
- Output Transistor Safe Operating area (SOA)Protection

Description

The 78MXX three-terminal positive regulators are available in the TO-252 package with several fixed output voltages making it useful in a wide range of applications.

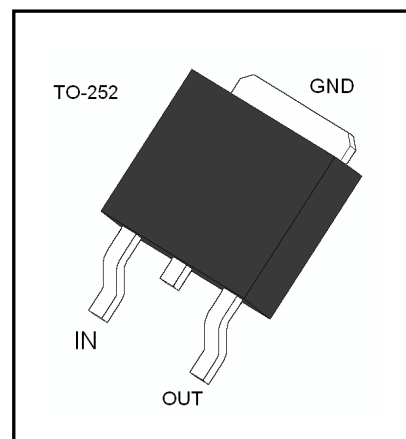

Internal Block Diagram

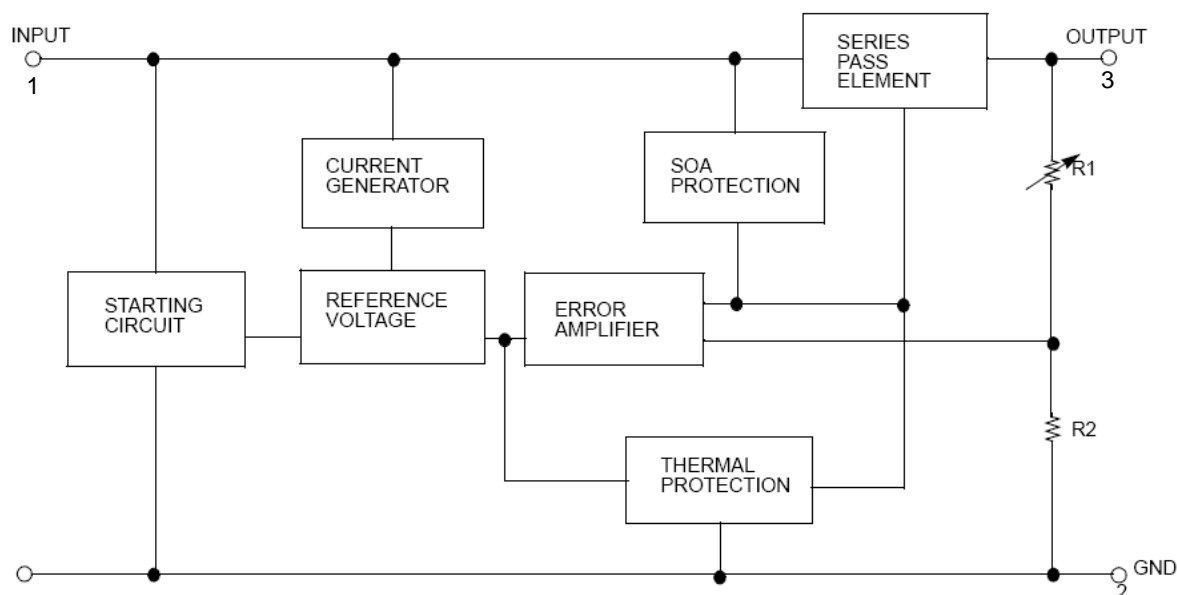

Absolute Maximum Ratings

Parameter	Symbol	Value	Unit
Input Voltage (for $V_O = 5V$ to $18V$) (for $V_O = 24V$)	V_{IN}	35 40	V
Thermal Resistance Junction-Case	$R_{\theta JC}$	2.5	$^{\circ}C/W$
Thermal Resistance Junction-Air ($T_a = +25^{\circ}C$)	$R_{\theta JA}$	92	$^{\circ}C/W$
Operating Junction Temperature Range	T_{OPR}	0 ~ 150	$^{\circ}C$
Storage Temperature Range	T_{STG}	-55 ~ + 150	$^{\circ}C$

Electrical Characteristics (78M05A)

(Refer to the test circuits, $0 < T_J < +125^{\circ}\text{C}$, $I_O=350\text{mA}$, $V_I=10\text{V}$, unless otherwise specified, $C_I = 0.33\mu\text{F}$, $C_O=0.1\mu\text{F}$)

Parameter	Symbol	Conditions	Value			Unit
			Min	Typ	Max	
Output Voltage	V_O	$I_O = 5\text{mA} \sim 350\text{mA}$ $V_I = 7 \sim 20\text{V}$	4.75	5	5.25	V
Line Regulation(Note)	ΔV_O	$I_O = 200\text{mA}$ $T_J = 25^{\circ}\text{C}$	$V_I = 7\text{V} \sim 25\text{V}$		100	mV
			$V_I = 8\text{V} \sim 25\text{V}$		50	
Load Regulation(Note)	ΔV_O	$T_J = 25^{\circ}\text{C}$	$I_O = 5\text{mA} \sim 500\text{mA}$		100	mV
			$I_O = 5\text{mA} \sim 200\text{mA}$		50	
Quiescent Current	I_Q	$T_J = 25^{\circ}\text{C}$			8.0	mA
Quiescent Current Change	ΔI_Q	$I_O = 5\text{mA} \sim 350\text{mA}$			0.5	mA
		$I_O = 200\text{mA}$, $V_I = 8 \sim 25\text{V}$			0.8	
Output Voltage Drift	$\Delta V / \Delta T$	$I_O = 5\text{mA}$, $T_J = 0 \sim 125^{\circ}\text{C}$		-0.5		mV/ $^{\circ}\text{C}$
Output Noise Voltage	V_N	$f = 10\text{Hz} \sim 100\text{KHz}$		40		μV
Ripple Rejection	RR	$f = 120\text{Hz}$, $V_I = 8 \sim 18\text{V}$		80		dB
Dropout Voltage	V_D	$T_J = 25^{\circ}\text{C}$, $I_O = 500\text{mA}$		2		V
Short Circuit Current	I_{SC}	$T_J = 25^{\circ}\text{C}$, $V_I = 35\text{V}$		300		mA
Peak Current	I_{PK}	$T_J = 25^{\circ}\text{C}$		700		mA

Notes:

Load and line regulation are specified at constant junction temperature. Change in V_O due to heating effects must be taken into account separately. Pulse testing with low duty is used.

Electrical Characteristics (78M06A)

(Refer to the test circuits, $0 < T_j < +125^{\circ}\text{C}$, $I_o=350\text{mA}$, $V_i=11\text{V}$, unless otherwise specified, $C_i = 0.33\mu\text{F}$, $C_o=0.1\mu\text{F}$)

Parameter	Symbol	Conditions	Value			Unit	
			Min	Typ	Max		
Output Voltage	V_o	$I_o = 5\text{mA} \sim 350\text{mA}$ $V_i = 8 \sim 21\text{V}$	5.7	6	6.3	V	
Line Regulation(Note)	ΔV_o	$I_o = 200\text{mA}$ $T_j = 25^{\circ}\text{C}$	$V_i = 8\text{V} \sim 25\text{V}$			100	mV
			$V_i = 9\text{V} \sim 25\text{V}$			50	
Load Regulation(Note)	ΔV_o	$T_j = 25^{\circ}\text{C}$	$I_o = 5\text{mA} \sim 500\text{mA}$			120	mV
			$I_o = 5\text{mA} \sim 200\text{mA}$			60	
Quiescent Current	I_Q	$T_j = 25^{\circ}\text{C}$				8.0	mA
Quiescent Current Change	ΔI_Q	$I_o = 5\text{mA} \sim 350\text{mA}$				0.5	mA
		$I_o = 200\text{mA}$, $V_i = 9 \sim 25\text{V}$				0.8	
Output Voltage Drift	$\Delta V / \Delta T$	$I_o = 5\text{mA}$, $T_j = 0 \sim 125^{\circ}\text{C}$		-0.5			mV/ $^{\circ}\text{C}$
Output Noise Voltage	V_N	$f = 10\text{Hz} \sim 100\text{KHz}$		45			μV
Ripple Rejection	RR	$f = 120\text{Hz}$, $V_i = 9 \sim 19\text{V}$		80			dB
Dropout Voltage	V_D	$T_j = 25^{\circ}\text{C}$, $I_o = 500\text{mA}$		2			V
Short Circuit Current	I_{SC}	$T_j = 25^{\circ}\text{C}$, $V_i = 35\text{V}$		300			mA
Peak Current	I_{PK}	$T_j = 25^{\circ}\text{C}$		700			mA

Notes:

Load and line regulation are specified at constant junction temperature. Change in V_o due to heating effects must be taken into account separately. Pulse testing with low duty is used.

Electrical Characteristics (78M08A)

(Refer to the test circuits, $0 < T_j < +125^{\circ}\text{C}$, $I_o=350\text{mA}$, $V_i=14\text{V}$, unless otherwise specified, $C_i = 0.33\mu\text{F}$, $C_o=0.1\mu\text{F}$)

Parameter	Symbol	Conditions	Value			Unit
			Min	Typ	Max	
Output Voltage	V_o	$I_o = 5\text{mA} \sim 350\text{mA}$ $V_i = 10.5 \sim 23\text{V}$	7.6	8	8.4	V
Line Regulation(Note)	ΔV_o	$I_o = 200\text{mA}$ $T_j = 25^{\circ}\text{C}$	$V_i = 10.5\text{V} \sim 25\text{V}$		100	mV
			$V_i = 11\text{V} \sim 25\text{V}$		50	
Load Regulation(Note)	ΔV_o	$T_j = 25^{\circ}\text{C}$	$I_o = 5\text{mA} \sim 500\text{mA}$		160	mV
			$I_o = 5\text{mA} \sim 200\text{mA}$		80	
Quiescent Current	I_q	$T_j = 25^{\circ}\text{C}$			8.0	mA
Quiescent Current Change	ΔI_q	$I_o = 5\text{mA} \sim 350\text{mA}$			0.5	mA
		$I_o = 200\text{mA}$, $V_i = 10.5 \sim 25\text{V}$			0.8	
Output Voltage Drift	$\Delta V / \Delta T$	$I_o = 5\text{mA}$, $T_j = 0 \sim 125^{\circ}\text{C}$		-0.8		mV/ $^{\circ}\text{C}$
Output Noise Voltage	V_N	$f = 10\text{Hz} \sim 100\text{KHz}$		52		μV
Ripple Rejection	RR	$f = 120\text{Hz}$, $V_i = 11.5 \sim 21.5\text{V}$		80		dB
Dropout Voltage	V_D	$T_j = 25^{\circ}\text{C}$, $I_o = 500\text{mA}$		2		V
Short Circuit Current	I_{SC}	$T_j = 25$, $V_i = 35\text{V}$		300		mA
Peak Current	I_{PK}	$T_j = 25^{\circ}\text{C}$		700		mA

Notes:

Load and line regulation are specified at constant junction temperature. Change in V_o due to heating effects must be taken into account separately. Pulse testing with low duty is used.

Electrical Characteristics (78M09A)

(Refer to the test circuits, $0 < T_j < +125^{\circ}\text{C}$, $I_o=350\text{mA}$, $V_i=15\text{V}$, unless otherwise specified, $C_i = 0.33\mu\text{F}$, $C_o=0.1\mu\text{F}$)

Parameter	Symbol	Conditions	Value			Unit
			Min	Typ	Max	
Output Voltage	V_o	$I_o = 5\text{mA} \sim 350\text{mA}$ $V_i = 11.5 \sim 24\text{V}$	8.45	9	9.55	V
Line Regulation(Note)	ΔV_o	$I_o = 200\text{mA}$ $T_j = 25^{\circ}\text{C}$	$V_i = 11.5\text{V} \sim 25\text{V}$		100	mV
			$V_i = 12\text{V} \sim 25\text{V}$		50	
Load Regulation(Note)	ΔV_o	$T_j = 25^{\circ}\text{C}$	$I_o = 5\text{mA} \sim 500\text{mA}$		180	mV
			$I_o = 5\text{mA} \sim 200\text{mA}$		90	
Quiescent Current	I_q	$T_j = 25^{\circ}\text{C}$			8.0	mA
Quiescent Current Change	ΔI_q	$I_o = 5\text{mA} \sim 350\text{mA}$			0.5	mA
		$I_o = 200\text{mA}$, $V_i = 11.5 \sim 25\text{V}$			0.8	
Output Voltage Drift	$\Delta V / \Delta T$	$I_o = 5\text{mA}$, $T_j = 0 \sim 125^{\circ}\text{C}$		-0.8		mV/ $^{\circ}\text{C}$
Output Noise Voltage	V_N	$f = 10\text{Hz} \sim 100\text{KHz}$		52		μV
Ripple Rejection	RR	$f = 120\text{Hz}$, $V_i = 12.5 \sim 22.5\text{V}$		80		dB
Dropout Voltage	V_D	$T_j = 25^{\circ}\text{C}$, $I_o = 500\text{mA}$		2		V
Short Circuit Current	I_{SC}	$T_j = 25$, $V_i = 35\text{V}$		300		mA
Peak Current	I_{PK}	$T_j = 25^{\circ}\text{C}$		700		mA

Notes:

Load and line regulation are specified at constant junction temperature. Change in V_o due to heating effects must be taken into account separately. Pulse testing with low duty is used.

Electrical Characteristics (78M12A)

(Refer to the test circuits, $0 < T_j < +125^{\circ}\text{C}$, $I_o=350\text{mA}$, $V_i=19\text{V}$, unless otherwise specified, $C_i = 0.33\mu\text{F}$, $C_o=0.1\mu\text{F}$)

Parameter	Symbol	Conditions	Value			Unit
			Min	Typ	Max	
Output Voltage	V_o	$I_o = 5\text{mA} \sim 350\text{mA}$ $V_i = 14.5 \sim 27\text{V}$	11.4	12	12.6	V
Line Regulation(Note)	ΔV_o	$I_o = 200\text{mA}$ $T_j = 25^{\circ}\text{C}$	$V_i = 14.5\text{V} \sim 30\text{V}$		100	mV
			$V_i = 16\text{V} \sim 30\text{V}$		50	
Load Regulation(Note)	ΔV_o	$T_j = 25^{\circ}\text{C}$	$I_o = 5\text{mA} \sim 500\text{mA}$		240	mV
			$I_o = 5\text{mA} \sim 200\text{mA}$		120	
Quiescent Current	I_Q	$T_j = 25^{\circ}\text{C}$			8.0	mA
Quiescent Current Change	ΔI_Q	$I_o = 5\text{mA} \sim 350\text{mA}$			0.5	mA
		$I_o = 200\text{mA}$, $V_i = 14.5 \sim 30\text{V}$			0.8	
Output Voltage Drift	$\Delta V / \Delta T$	$I_o = 5\text{mA}$, $T_j = 0 \sim 125^{\circ}\text{C}$		-0.8		mV/ $^{\circ}\text{C}$
Output Noise Voltage	V_N	$f = 10\text{Hz} \sim 100\text{KHz}$		75		μV
Ripple Rejection	RR	$f = 120\text{Hz}$, $V_i = 15 \sim 25\text{V}$		80		dB
Dropout Voltage	V_D	$T_j = 25^{\circ}\text{C}$, $I_o = 500\text{mA}$		2		V
Short Circuit Current	I_{SC}	$T_j = 25$, $V_i = 35\text{V}$		300		mA
Peak Current	I_{PK}	$T_j = 25^{\circ}\text{C}$		700		mA

Notes:

Load and line regulation are specified at constant junction temperature. Change in V_o due to heating effects must be taken into account separately. Pulse testing with low duty is used.

Electrical Characteristics (78M15A)

(Refer to the test circuits, $0 < T_j < +125^{\circ}\text{C}$, $I_o=350\text{mA}$, $V_i=23\text{V}$, unless otherwise specified, $C_i = 0.33\mu\text{F}$, $C_o=0.1\mu\text{F}$)

Parameter	Symbol	Conditions	Value			Unit	
			Min	Typ	Max		
Output Voltage	V_o	$I_o = 5\text{mA} \sim 350\text{mA}$ $V_i = 17.5 \sim 30\text{V}$	14.25	15	15.75	V	
Line Regulation(Note)	ΔV_o	$I_o = 200\text{mA}$ $T_j = 25^{\circ}\text{C}$	$V_i = 17.5\text{V} \sim 30\text{V}$			100	mV
			$V_i = 20\text{V} \sim 30\text{V}$			50	
Load Regulation(Note)	ΔV_o	$T_j = 25^{\circ}\text{C}$	$I_o = 5\text{mA} \sim 500\text{mA}$			300	mV
			$I_o = 5\text{mA} \sim 200\text{mA}$			150	
Quiescent Current	I_q	$T_j = 25^{\circ}\text{C}$				8.0	mA
Quiescent Current Change	ΔI_q	$I_o = 5\text{mA} \sim 350\text{mA}$				0.5	mA
		$I_o = 200\text{mA}$, $V_i = 17.5 \sim 30\text{V}$				0.8	
Output Voltage Drift	$\Delta V / \Delta T$	$I_o = 5\text{mA}$, $T_j = 0 \sim 125^{\circ}\text{C}$		-1.0			mV/ $^{\circ}\text{C}$
Output Noise Voltage	V_N	$f = 10\text{Hz} \sim 100\text{KHz}$		100			μV
Ripple Rejection	RR	$f = 120\text{Hz}$, $V_i = 18.5 \sim 28.5\text{V}$		70			dB
Dropout Voltage	V_D	$T_j = 25^{\circ}\text{C}$, $I_o = 500\text{mA}$		2			V
Short Circuit Current	I_{SC}	$T_j = 25^{\circ}\text{C}$, $V_i = 35\text{V}$		300			mA
Peak Current	I_{PK}	$T_j = 25^{\circ}\text{C}$		700			mA

Notes:

Load and line regulation are specified at constant junction temperature. Change in V_o due to heating effects must be taken into account separately. Pulse testing with low duty is used.

Electrical Characteristics (78M18A)

(Refer to the test circuits, $0 < T_j < +125^{\circ}\text{C}$, $I_o=350\text{mA}$, $V_i=26\text{V}$, unless otherwise specified, $C_i = 0.33\mu\text{F}$, $C_o=0.1\mu\text{F}$)

Parameter	Symbol	Conditions	Value			Unit
			Min	Typ	Max	
Output Voltage	V_o	$I_o = 5\text{mA} \sim 350\text{mA}$ $V_i = 20.5 \sim 33\text{V}$	17.1	18	18.9	V
Line Regulation(Note)	ΔV_o	$I_o = 200\text{mA}$ $T_j = 25^{\circ}\text{C}$	$V_i = 21\text{V} \sim 33\text{V}$		100	mV
			$V_i = 24\text{V} \sim 33\text{V}$		50	
Load Regulation(Note)	ΔV_o	$T_j = 25^{\circ}\text{C}$	$I_o = 5\text{mA} \sim 500\text{mA}$		360	mV
			$I_o = 5\text{mA} \sim 200\text{mA}$		180	
Quiescent Current	I_q	$T_j = 25^{\circ}\text{C}$			8.0	mA
Quiescent Current Change	ΔI_q	$I_o = 5\text{mA} \sim 350\text{mA}$			0.5	mA
		$I_o = 200\text{mA}$, $V_i = 21 \sim 33\text{V}$			0.8	
Output Voltage Drift	$\Delta V / \Delta T$	$I_o = 5\text{mA}$, $T_j = 0 \sim 125^{\circ}\text{C}$		-1.2		mV/ $^{\circ}\text{C}$
Output Noise Voltage	V_N	$f = 10\text{Hz} \sim 100\text{KHz}$		100		μV
Ripple Rejection	RR	$f = 120\text{Hz}$, $V_i = 22 \sim 32\text{V}$		70		dB
Dropout Voltage	V_D	$T_j = 25^{\circ}\text{C}$, $I_o = 500\text{mA}$		2		V
Short Circuit Current	I_{SC}	$T_j = 25$, $V_i = 35\text{V}$		300		mA
Peak Current	I_{PK}	$T_j = 25^{\circ}\text{C}$		700		mA

Notes:

Load and line regulation are specified at constant junction temperature. Change in V_o due to heating effects must be taken into account separately. Pulse testing with low duty is used.

Electrical Characteristics (78M24A)

(Refer to the test circuits, $0 < T_j < +125^{\circ}\text{C}$, $I_o=350\text{mA}$, $V_i=33\text{V}$, unless otherwise specified, $C_1 = 0.33\mu\text{F}$, $C_o=0.1\mu\text{F}$)

Parameter	Symbol	Conditions	Value			Unit
			Min	Typ	Max	
Output Voltage	V_o	$I_o = 5\text{mA} \sim 350\text{mA}$ $V_i = 27 \sim 38\text{V}$	22.8	24	25.2	V
Line Regulation(Note)	ΔV_o	$I_o = 200\text{mA}$ $T_j = 25^{\circ}\text{C}$	$V_i = 27\text{V} \sim 38\text{V}$		100	mV
			$V_i = 28\text{V} \sim 38\text{V}$		50	
Load Regulation(Note)	ΔV_o	$T_j = 25^{\circ}\text{C}$	$I_o = 5\text{mA} \sim 500\text{mA}$		480	mV
			$I_o = 5\text{mA} \sim 200\text{mA}$		240	
Quiescent Current	I_q	$T_j = 25^{\circ}\text{C}$			8.0	mA
Quiescent Current Change	ΔI_q	$I_o = 5\text{mA} \sim 350\text{mA}$			0.5	mA
		$I_o = 200\text{mA}$, $V_i = 27 \sim 38\text{V}$			0.8	
Output Voltage Drift	$\Delta V / \Delta T$	$I_o = 5\text{mA}$, $T_j = 0 \sim 125^{\circ}\text{C}$		-1.2		mV/ $^{\circ}\text{C}$
Output Noise Voltage	V_N	$f = 10\text{Hz} \sim 100\text{KHz}$		170		μV
Ripple Rejection	RR	$f = 120\text{Hz}$, $V_i = 28 \sim 38\text{V}$		70		dB
Dropout Voltage	V_D	$T_j = 25^{\circ}\text{C}$, $I_o = 500\text{mA}$		2		V
Short Circuit Current	I_{SC}	$T_j = 25$, $V_i = 35\text{V}$		300		mA
Peak Current	I_{PK}	$T_j = 25^{\circ}\text{C}$		700		mA

Notes:

Load and line regulation are specified at constant junction temperature. Change in V_o due to heating effects must be taken into account separately. Pulse testing with low duty is used.

Package Mechanical Data TO-252

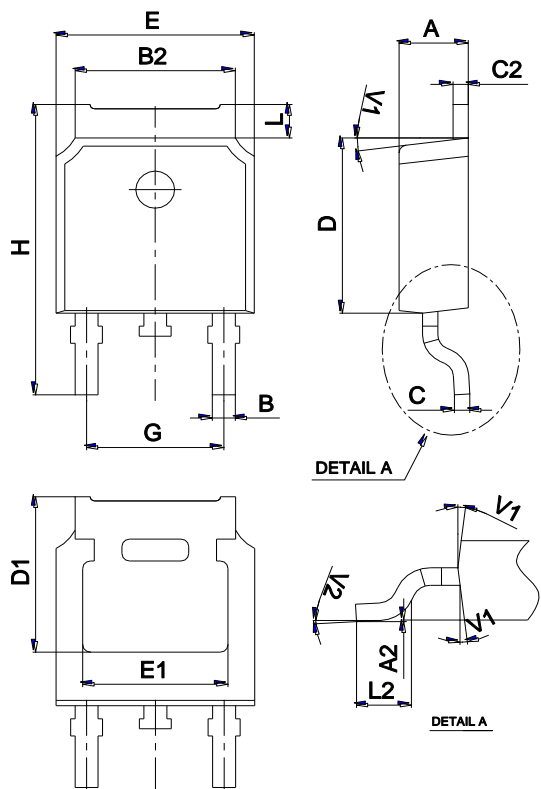

Ref.	Dimensions					
	Millimeters			Inches		
	Min.	Typ.	Max.	Min.	Typ.	Max.
A	2.10		2.50	0.083		0.098
A2	0		0.10	0		0.004
B	0.66		0.86	0.026		0.034
B2	5.18		5.48	0.202		0.216
C	0.40		0.60	0.016		0.024
C2	0.44		0.58	0.017		0.023
D	5.90		6.30	0.232		0.248
D1	5.30REF			0.209REF		
E	6.40		6.80	0.252		0.268
E1	4.63			0.182		
G	4.47		4.67	0.176		0.184
H	9.50		10.70	0.374		0.421
L	1.09		1.21	0.043		0.048
L2	1.35		1.65	0.053		0.065
V1		7°			7°	
V2	0°		6°	0°		6°

Ordering information

Order code	Package	Baseqty	Deliverymode
UMW 78MxxA	TO-252	2500	Tape and reel