

BNUBT32A05L02

ESD Protection Diode

Features

- 72W Peak pulse power per line (tp = 8/20µs)
- Unidirectional configurations
- Solid-state silicon-avalanche technology
- Low clamping voltage
- Low leakage current
- IEC 61000-4-2 ±15kV contact ; ±20kV air
- IEC 61000-4-4 (EFT) 40A (5/50ns)
- IEC 61000-4-5 (Lightning) 4.0A(8/20µs)

Package

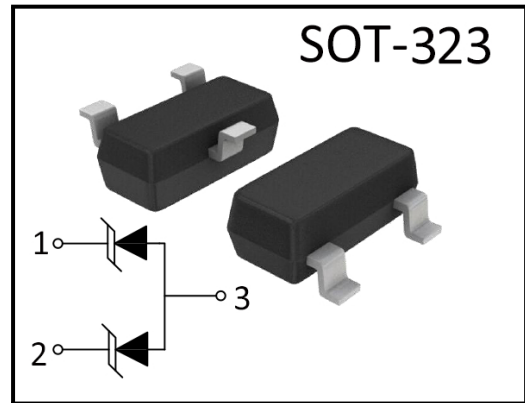

Mechanical Characteristics

- Dataline
- Automatic Teller Machines
- Net works
- Power line

Applications

- SOT-323 package
- Molding compound flammability rating: UL 94V-0
- Packaging: Tape and Reel
- RoHS/WEEE Compliant

Marking

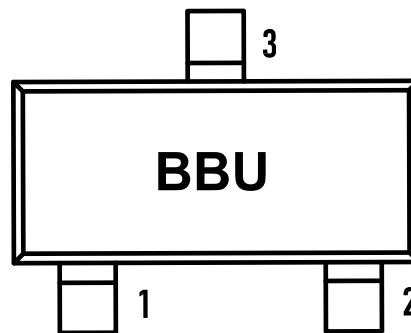

Ordering information

Order code	Package	Base qty	Delivery mode
BNUBT32A05L02	SOT-323	3K	Tape and reel



Electrical Parameters ($T_A = 25^\circ\text{C}$ unless otherwise noted)

Symbol	Parameter
V_{RWM}	Peak Reverse Working Voltage
I_R	Reverse Leakage Current @ V_{RWM}
V_{BR}	Breakdown Voltage @ I_T
I_T	Test Current
I_{PP}	Maximum Reverse Peak Pulse Current
V_C	Clamping Voltage @ I_{PP}

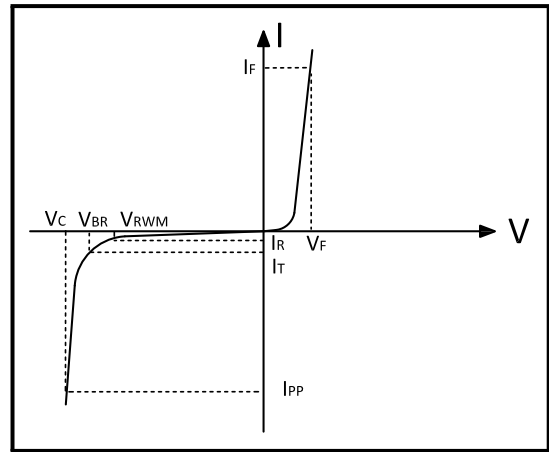

Absolute Maximum Rating

Rating	Symler	Value	Units
Peak Pulse Power ($t_p = 8/20\mu\text{s}$)	P_{PP}	72	Watts
Peak Pulse Current ($t_p = 8/20\mu\text{s}$)	I_{PP}	4.0	A
ESD per IEC 61000-4-2 (Air)	V_{ESD}	20	KV
ESD per IEC 61000-4-2 (Contact)		15	
Lead Soldering Temperature	T_L	260(10seconds)	$^\circ\text{C}$
Junction Temperature	T_J	-55 to + 150	$^\circ\text{C}$
Storage Temperature	T_{stg}	-55 to + 150	$^\circ\text{C}$

Electrical Characteristics

Parameter	Symler	Conditions	Min	Typical	Max	Units
Reverse Stand-Off Voltage	V_{RWM}	-	-	-	5.0	V
Reverse Breakdown Voltage	V_{BR}	$I_T = 1\text{mA}$	6.0	7.5	9.5	V
Reverse Leakage Current	I_R	$V_{RWM} = 5\text{V}, T = 25^\circ\text{C}$	-	-	0.5	μA
Peak Pulse Current	I_{PP}	$t_p = 8/20\mu\text{s}$	-	-	4.0	A
Clamping Voltage	V_C	$I_{PP} = 4.0\text{A}, t_p = 8/20\mu\text{s}$	-	15	18	V
Junction Capacitance	C_j	$V_R = 0\text{V}, T = 25^\circ\text{C}, f = 1\text{MHz}$	-	0.3	0.5	pF





BNUBT32A05L02

ESD Protection Diode

Typical Characteristics

Figure 1: Peak Pulse Power vs. Pulse Time

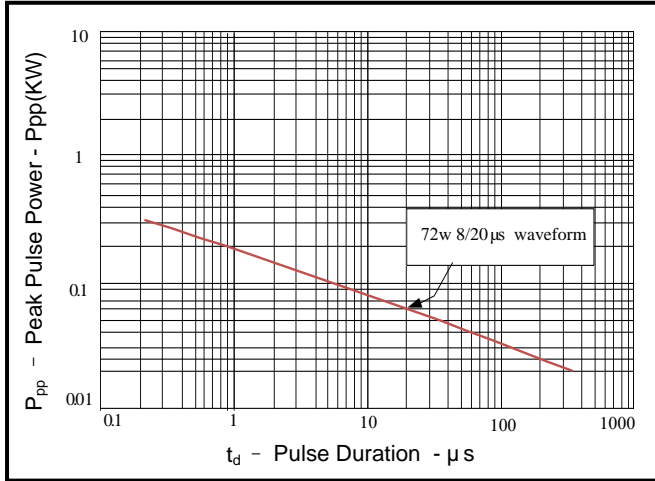

Figure 2: Power Derating Curve

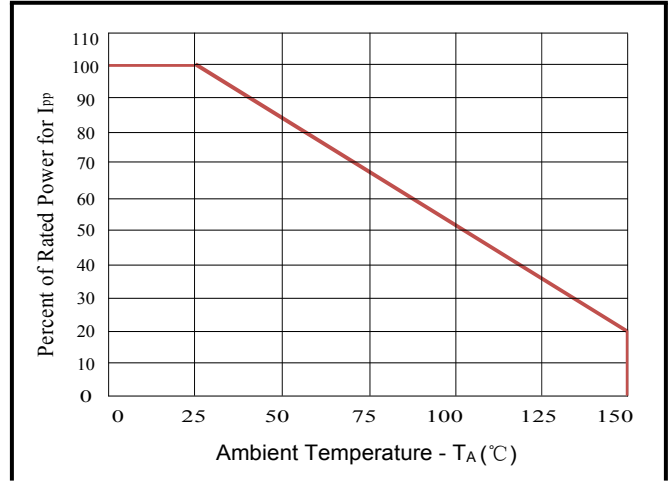

Figure 3: Pulse Waveform

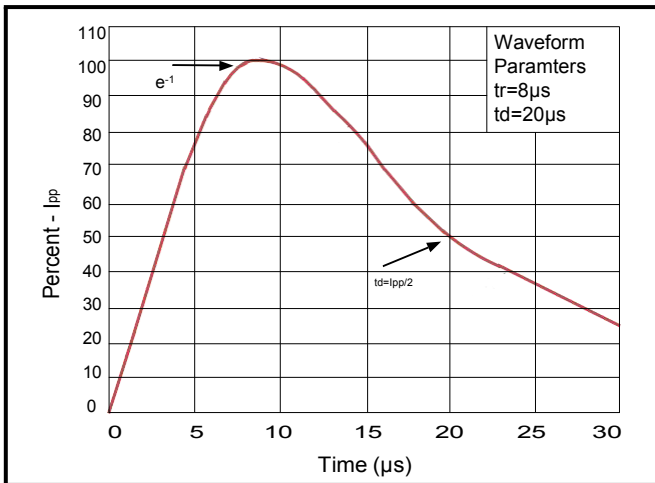
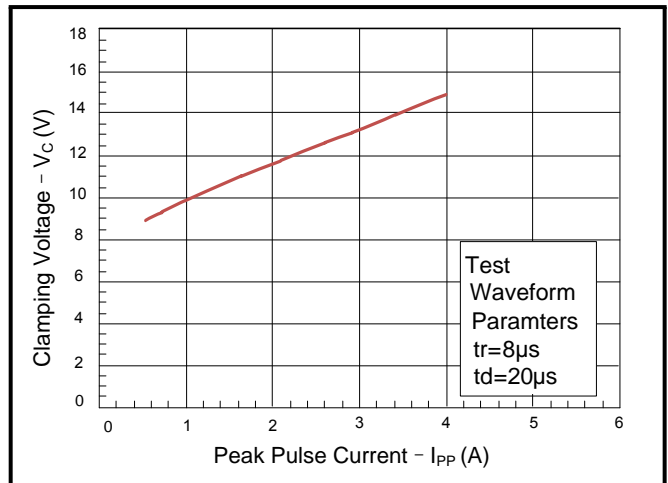

Figure 4: Clamping Voltage vs. I_PP



BNUBT32A05L02

ESD Protection Diode

Outline Drawing – SOT-323

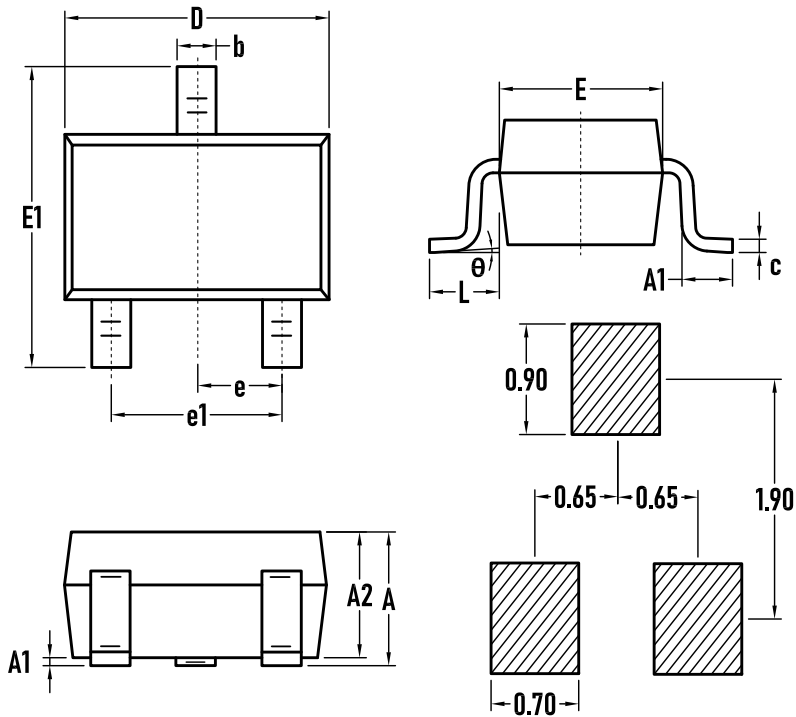

SYMBOL	MILLIMETER		
	MIN.	Typ.	MAX.
A	0.90	1.00	1.10
A1	0.00	0.05	0.10
A2	0.90	0.95	1.00
b	0.20	0.30	0.40
c	0.08	0.12	0.15
D	2.00	2.10	2.20
E1	2.15	2.30	2.45
E	1.15	1.25	1.35
e	0.650Typ.		
e1	1.20	1.30	1.40
L	0.26	0.36	0.46
θ	0	4°	8°

