

■ Features

- Ultra low profile.
- Magnetic shielded for low radiation.
- Bobbin ferrite core and compact size.
- Low core loss for high frequency power application.
- Large terminal surface for good PCB bonding.
- Operating temperature: -40°C ~ +125°C.

■ Applications

- Portable communication equipment.
- Notebook PC, digital camera, LCD television set.
- Power supply for VTR, OA equipment.
- DC/DC converters.

■ Product Identification

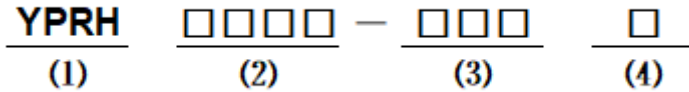

(1) : Type

(2) : Dimensions

(3) : Inductance value

(4) : Inductance Tolerance; N=±30%, M=±20%, K=±10%

■ Shapes and Dimensions (Unit: mm)

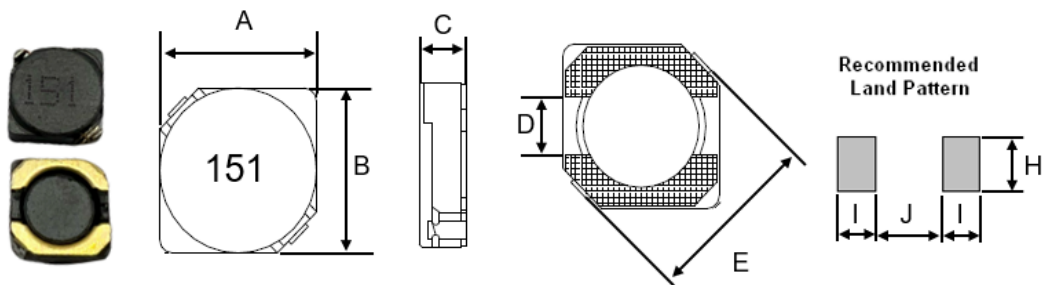

TYPE	A	B	C Max.	D Ref.	E Max.	H Ref.	I Ref.	J Ref.
YPRH6D28	6.7±0.3	6.7±0.3	3.2	2.00	9.5	7.3	2.65	2.0

■ Electrical Characteristics

Part Number	Inductance	Test Frequency	DCR Max.(Ω)	Isat Max.(A)
YPRH6D28-151M	150uH±20%	100KHz/0.25V	0.75	0.40

- ※ The saturation current value is the DC current value having inductance decrease down to 30%.(at 25°C)
- ※ The temperature rise current value is the DC current value having temperature increase up to 40°C. (at 25°C)
- ※ The rated current is the DC current value that satisfies both of current value saturation current value and temperature rise current value.

■ Material List

NO.	ITEM	MATERIAL DESCRIPTION	SUPPLIER	REMARK
1	CORE	DL5	TAK	or Equivalent
2	WIRE	2UEWH	PACIFIC	or Equivalent
3	BASE	6D28	HUIGAO	or Equivalent
4	EPOXY	S9001	WELLS	or Equivalent
5	SOLDER	SN99.3CU0.7	XINJINCHUN	or Equivalent
6	MARKING	151 Black	SENUON TRADING	or Equivalent

■ Taping Dimensions(Unit:mm)

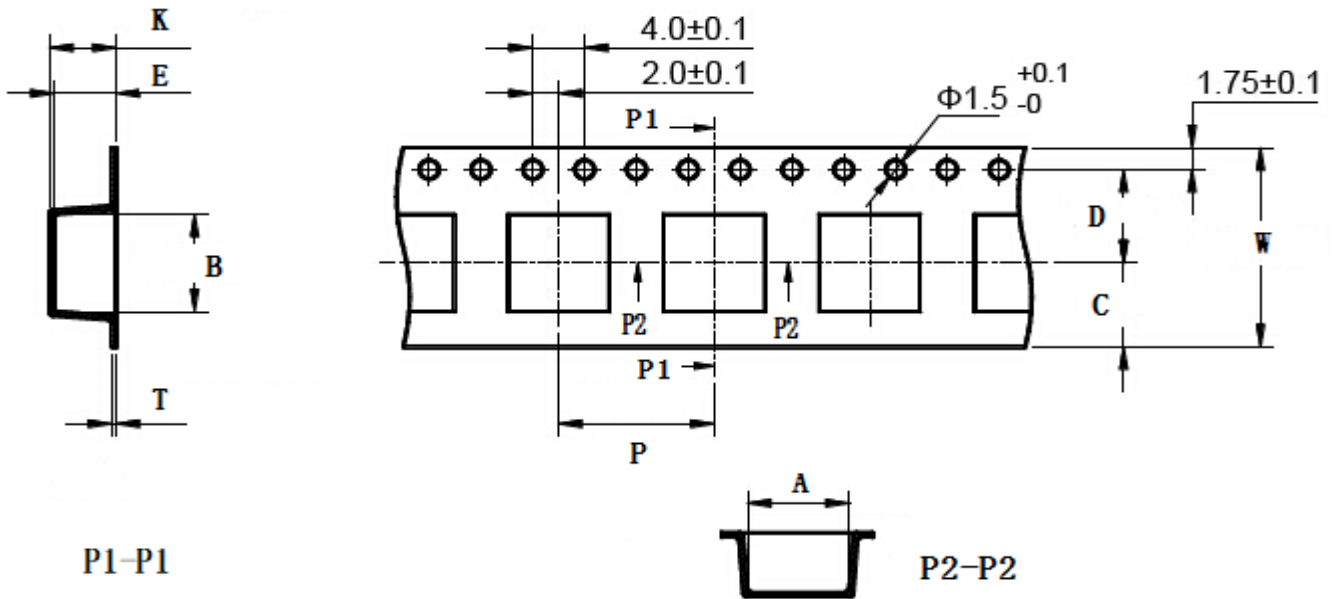

TYPE	W	A	B	C	D	E	P	K Ref	T	MPQ
YPRH6D28	16±0.3	8.85±0.1	7.10±0.1	6.75	7.5±0.1	2.95±0.1	12±0.1	3.15	0.30±0.05	1500

■ Reel Dimensions(Unit:mm)

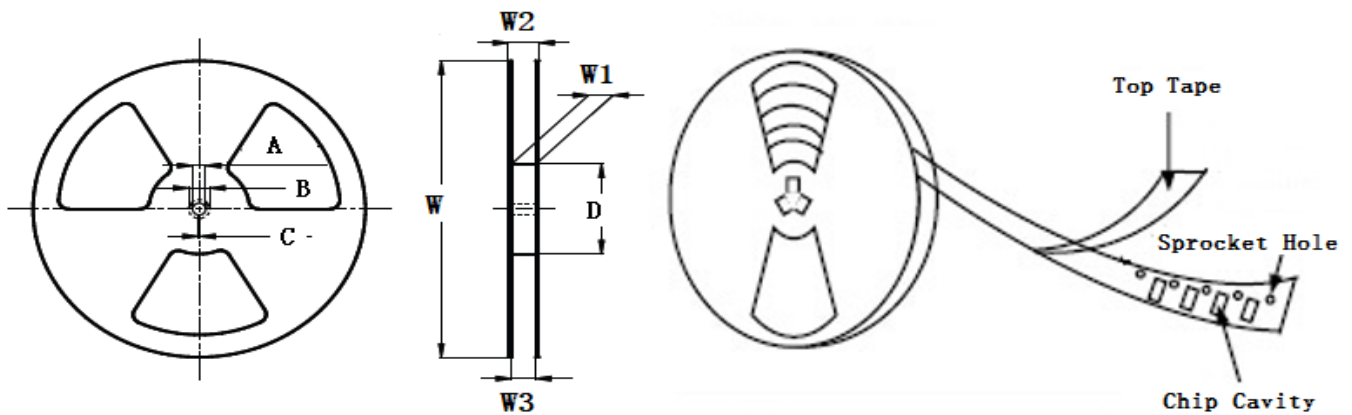

TYPE	W	W1	W2	W3	A	B	C	D
YPRH6D28	330±2.0	16.4±2.0	22.4 Max	15.9 Min	13.0±0.50	21.0±0.80	2.0±0.50	100 Min

Direction of rolling

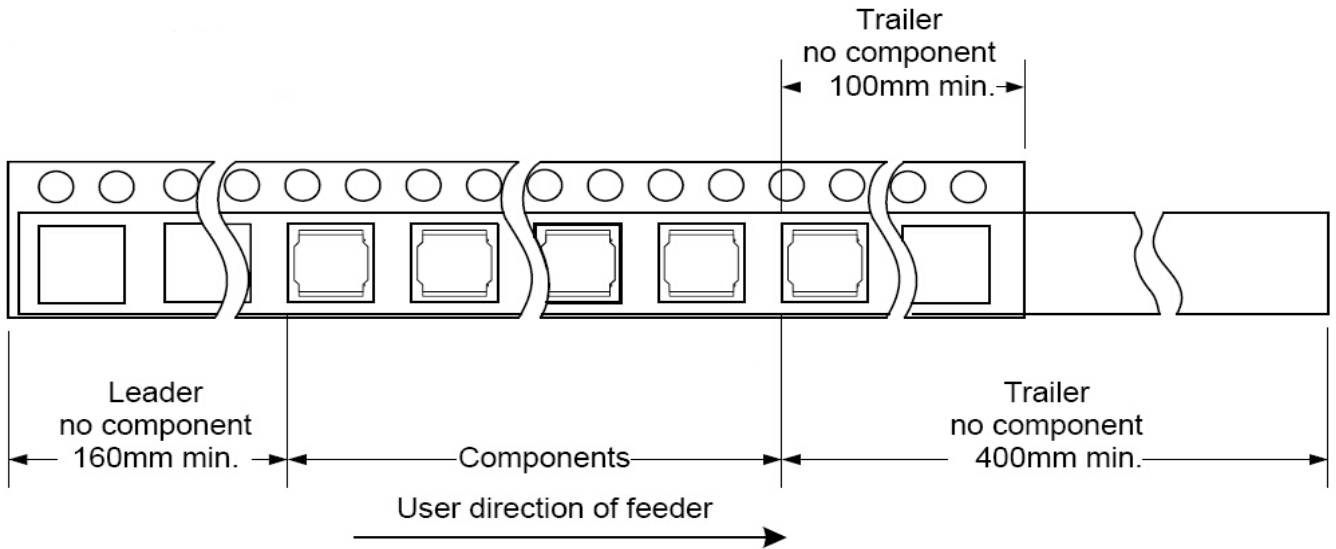

Cover tape peel off condition

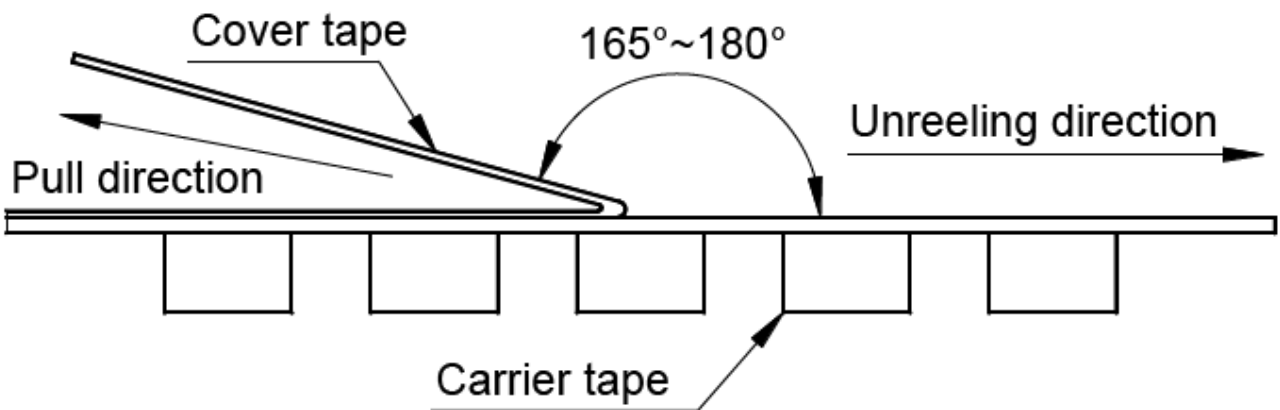

Cover tape peel force shall be 0.1N to 1.3N.

Reference peel speed 300±10mm/min.