

REV	MARK	DESCRIPTION	DRAFTED. BY	DATE

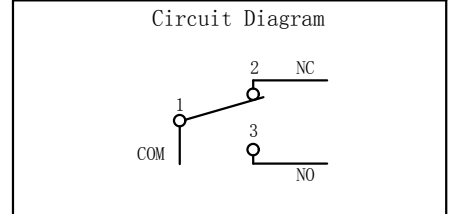
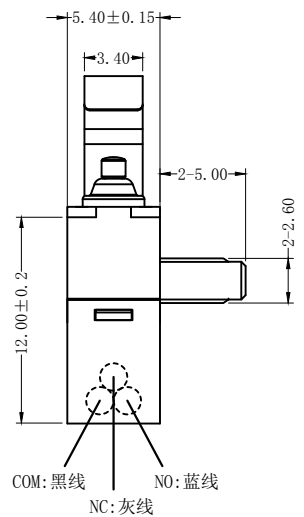
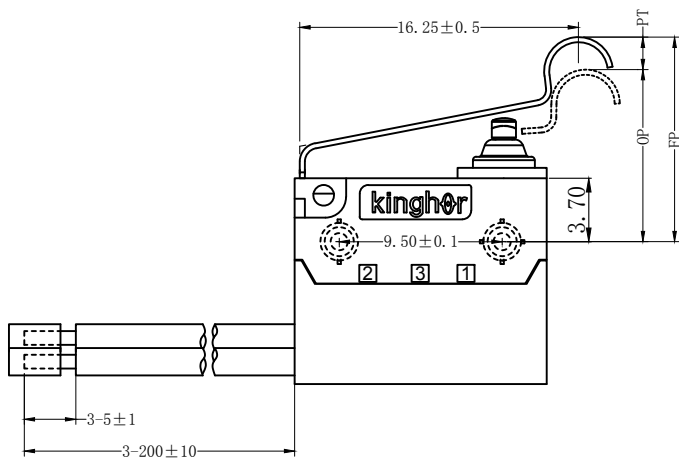
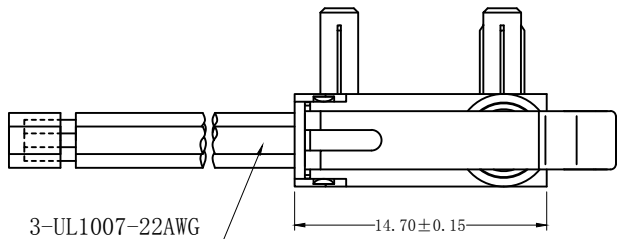

CHARACTERISTICS	
OPERATING FORCE (OF):	180gf Max.
RELEASE FORCE (RF):	20gf Min.
OPERATING POSITION:	10.7 ± 0.7 mm.
PRE TRAVEL:	3.80mm Max.
DIFFERENTIAL TRAVEL:	0.70mm Max.
FREE POSITION:	13.5mm Max.

ELECTRICAL DATA	
RATING	OPERATING LIFE
3A 12VDC	100,000 CYCLES
0.1A 48VDC 125/250VAC	100,000 CYCLES

MECHANICAL LIFE	500,000 CYCLES
GAP TYPE	MICRO
OPERATING TEMP	-25°C ~ +85°C
WATERPROOF	IP67

OUTLINE DRAWING			
TITLE	H3 SERIES MICRO SWITCH		
MODEL	H3-A3		
PART NO.	H3-A3-1D05W2-2-200		
DRAFTED BY	Bing Wang	DATE	2023-12-29
CHECKED BY	Shigang You	DATE	2023-12-29
APPROVED BY	Henghua Dai	DATE	2023-12-29

TOLERANCE UNLESS OTHERWISE SPECIFIED							
≤3	1~3	3~10	10~30	30~100	100~200	ANGLE	
±0.2	±0.3	±0.4	±0.6	±1.0	±1.5	±3.0°	
						SCALE	
						UNIT	
						VERSION	REV
						A1	A1

**KINGHOR**  
SWITCH AND CONTROL EXPERT