



## 2.1A,40V Synchronous Rectifier

### Description

NDP7821KC is a synchronous rectifier for switch mode power supplies, which combines an N-Channel MOSFET and a driver circuit designed for synchronous rectification in DCM, QR and CCM operation

The synchronous rectification can effectively reduce the secondary side rectifier power dissipation and provide high performance solution. By sensing MOSFET SW-to-source voltage, NDP7821KC can output ideal drive signal with less external components. It can provide high performance solution for 5V output voltage application.

### Features

- Supports CCM, DCM and Quasi-Resonant Topologies
- Supports Low-side Rectification
- Max 150kHz Switching Frequency
- Fast Turn-off Total Delay of 30ns
- Compatible with Energy Star
- ~150uA Low Quiescent Current
- Available in SOP8 Package

### Applications

- Chargers for Cell Phones
- AC/DC adapter
- Industrial Power Systems
- Flyback Converters

### Typical Application

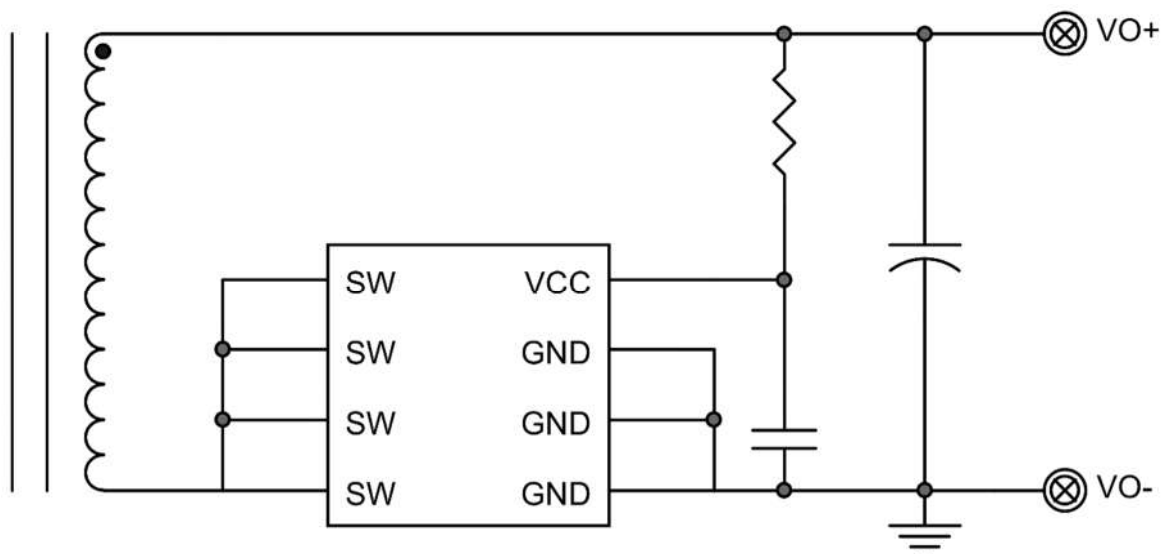

**Absolute Maximum Ratings (at TA = 25°C)**

Characteristics	Symbol	Rating	Unit
VCC to GND		-0.3 to 6.5	V
SW to GND		-0.3 to 45	V
Operating Junction Temperature		-40 to 150	°C
Storage Junction Temperature		-55 to 150	°C
Thermal Resistance from Junction to case	$\theta_{JC}$	80	°C/W
Thermal Resistance from Junction to ambient	$\theta_{JA}$	160	°C/W

**Pin Function And Descriptions**

PIN	NAME	Description
1,2,3	GND	Ground
4	VCC	Power supply
5,6,7,8	SW	Drain of internal N-MOS

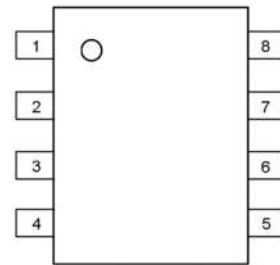
**Order information**

Order Information	Top Marking
<p>NDP7821 K C</p> <p>Pin NO. C:8 Package K: SOP Product Number</p>	<p>DY: Year (D8=2018, D9=2019,...) WW: Weekly (01-53) X : Internal ID Code</p>



## Electrical Characteristics

T<sub>J</sub> = 25°C. V<sub>CC</sub> = 5V, unless otherwise noted

Characteristics	Symbol	Conditions	Min	Typ	Max	Units
Input Voltage	V <sub>CC</sub>		3.6	-	6.0	V
UVLO Voltage	V <sub>UVLO</sub>			2.3		V
UVLO Hysteresis				0.2		V
V <sub>CC</sub> voltage clamp	V <sub>ovp</sub>			6.2		V
Quiescent Current	I <sub>CCQ</sub>	no switch	-	150	-	uA
Turn on Threshold	V <sub>TH_ON</sub>			-170		mV
Driver Voltage Regulator	V <sub>reg</sub>			-37		mV
Turn OFF Threshold	V <sub>TH_OFF</sub>			-20		mV
Turn-off Total Delay	T <sub>off_delay</sub>			30		nS
Minimum on time	T <sub>min</sub>			1.7		uS
NMOS R <sub>DS(on)</sub>	R <sub>DS</sub>			24		mΩ
Breakdown Voltage	B <sub>VDSS</sub>		45			V
Thermal shutdown Temp	T <sub>SD</sub>		-	150	-	°C
Thermal Shutdown Hysteresis	T <sub>SH</sub>		-	30	-	°C

## Block Diagram

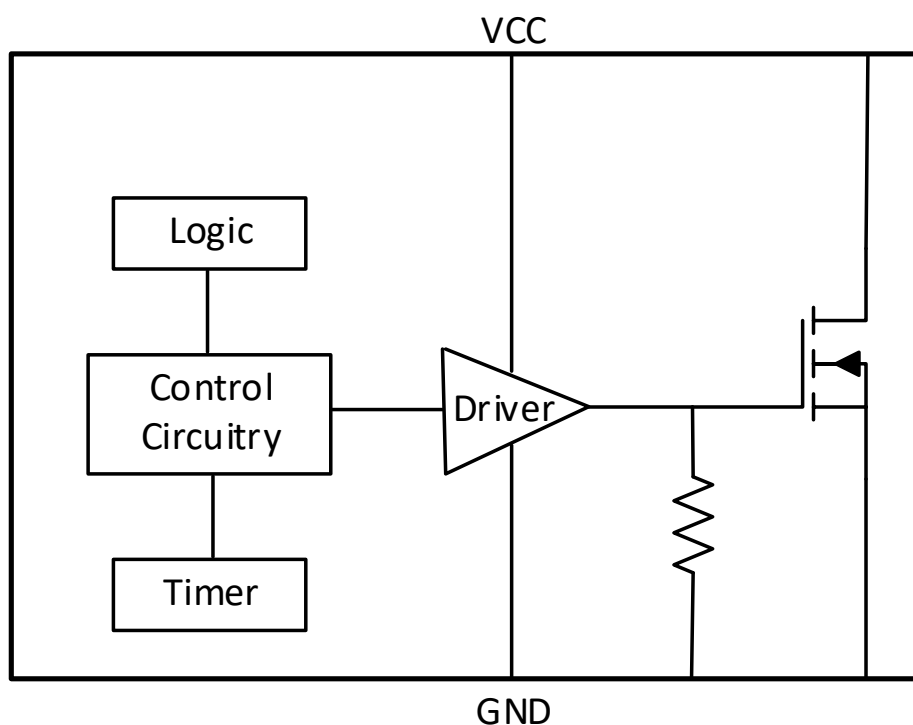



## Operation

The NDP7821KC supports operation in CCM, DCM and Quasi-Resonant topologies. Operating in either a DCM or Quasi-Resonant topology, the control circuitry controls the gate in forward mode and will turn the gate off when the MOSFET current is fairly low. In CCM operation, the control circuitry turns off the gate when very fast transients occur.

### VCC Under voltage lockout(UVLO)

When the Vcc is below UVLO threshold, the part is in sleep mode and the internal N-MOS will be turn off.

### Turn ON phase

When the synchronous MOSFET is conducting, current will flow through its body diode which generates a negative Vds across it. Because this body diode voltage drop is much smaller than the turn on threshold of the control circuitry (-170mV), which will then turn on the N-MOS.

### Conducting Phase

When the synchronous N-MOS is turned on, Vds becomes to rise according to its on resistance, as the current become smaller Vds rises above the Driver Voltage Regulator (-37mV), the circuitry starts pulling down the gate driver which leads to the VDS be regulated to a fixed voltage (the internal reference).

### Turn OFF phase

When the Vds rises to trigger the turn off threshold(-20mV), the N-MOS gate voltage is pulled to low after about 30nS delay by the control circuitry, a 1.7uS blanking time is added after the synchronous N-MOS is turn off to avoid error trigger because of the ringing.

## Blanking

The NDP7821KC control circuitry contains a blanking function. When it pulls the MOSFET OFF, it makes sure that the OFF state at least lasts for about ~1.7us, so it is not recommended to set the synchronous period less than 1.6us at CCM condition in flyback converter, otherwise shoot through may occur During normal operation.

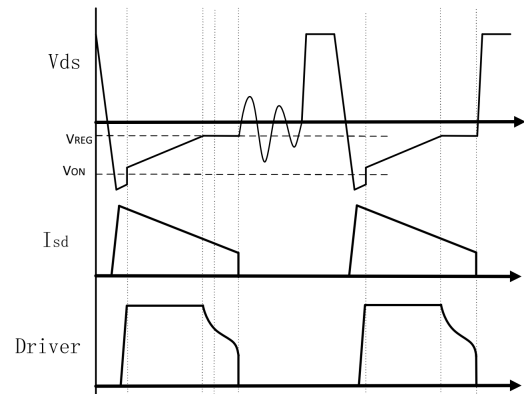

Figure 1

### Operation in DCM mode

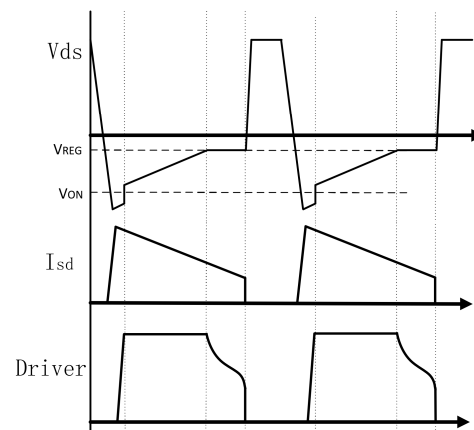

Figure 2

### Operation in CCM mode



## Package Description

8-Lead Standard Small Outline Package [SOP-8]

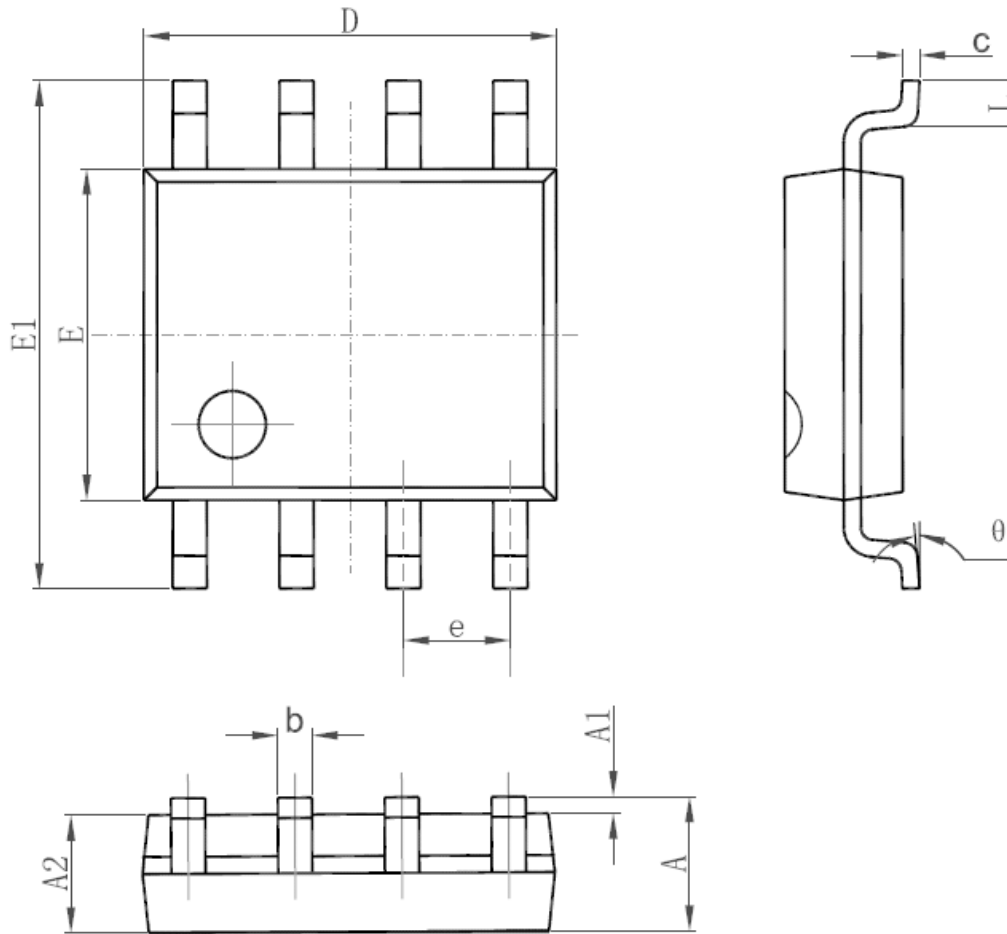

Symbol	Dimensions In Millimeters		Dimensions In Inches	
	Min	Max	Min	Max
A	1.350	1.750	0.053	0.069
A1	0.050	0.250	0.002	0.010
A2	1.250	1.650	0.049	0.065
b	0.310	0.510	0.012	0.020
c	0.170	0.250	0.006	0.010
D	4.700	5.150	0.185	0.203
E	3.800	4.000	0.15	0.157
E1	5.800	6.200	0.228	0.244
e	1.270 (BSC)		0.05 (BSC)	
L	0.400	1.270	0.016	0.050
$\theta$	0°	8°	0°	8°