

## General Description

The LM1117 is a series of low dropout three-terminal regulators with a dropout of 1.15V at 1A output current.

The LM1117 series provides current limiting and thermal shutdown. Its circuit includes an immed bandgap reference to assure output voltage accuracy to be within 1% for 1.5V, 1.8V, 2.5V, 2.85V, 3.3V, 5.0V and adjustable versions or 2% for 1.2V version. Current limit is immed to ensure specified output current and conolled short-circuit current. On-chip thermal shutdown provides protection against any combination of overload and ambient temperature that would create excessive junction temperature.

The LM1117 has an adjustable version, that can provide the output voltage from 1.25V to 12V with only 2 external resistors.

The LM1117 series is available in the indusy standard SOT-223, SOT-89-3, TO-220-3, TO-252-2 and TO-263-3 power packages.

## Features

- Low Dropout Voltage: 1.15V at 1A Output Current
- immed Current Limit
- On-chip Thermal Shutdown
- Three-terminal Adjustable or Fixed 1.2V, 1.5V, 1.8V, 2.5V, 2.85V, 3.3V, 5.0V
- Operation Junction Temperature: -40 to 125°C

## Applications

- PC Motherboard
- LCD Monitor
- Graphic Card
- DVD-video Player
- NIC/Switch
- Telecom Equipment
- ADSL Modem
- Printer and other Peripheral Equipment

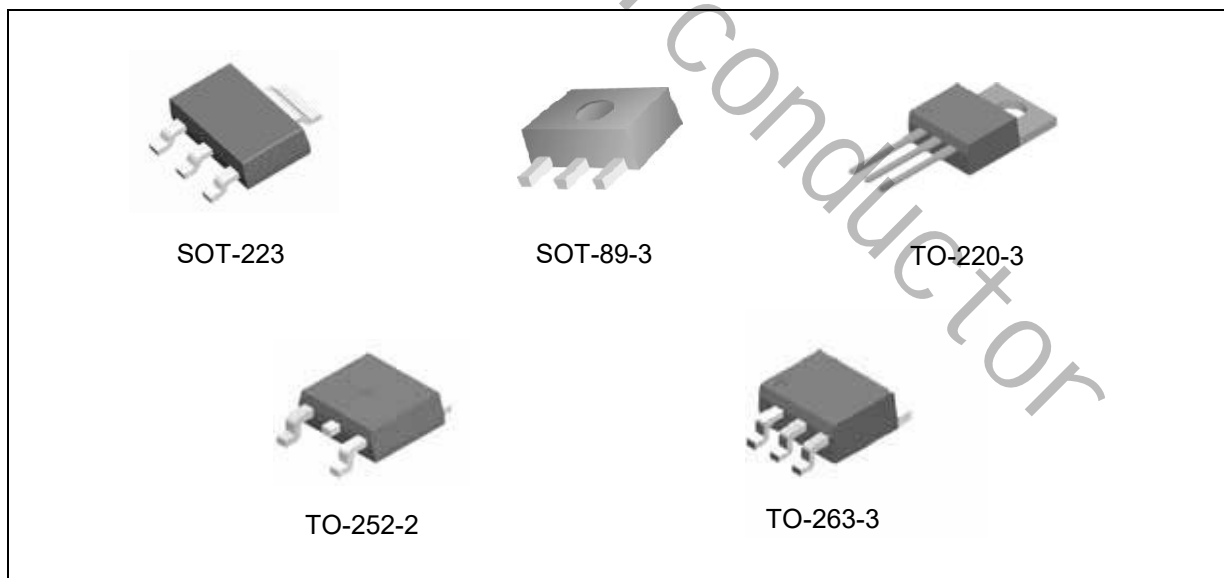

Figure 1. Package Types of LM1117

**Pin Configuration**

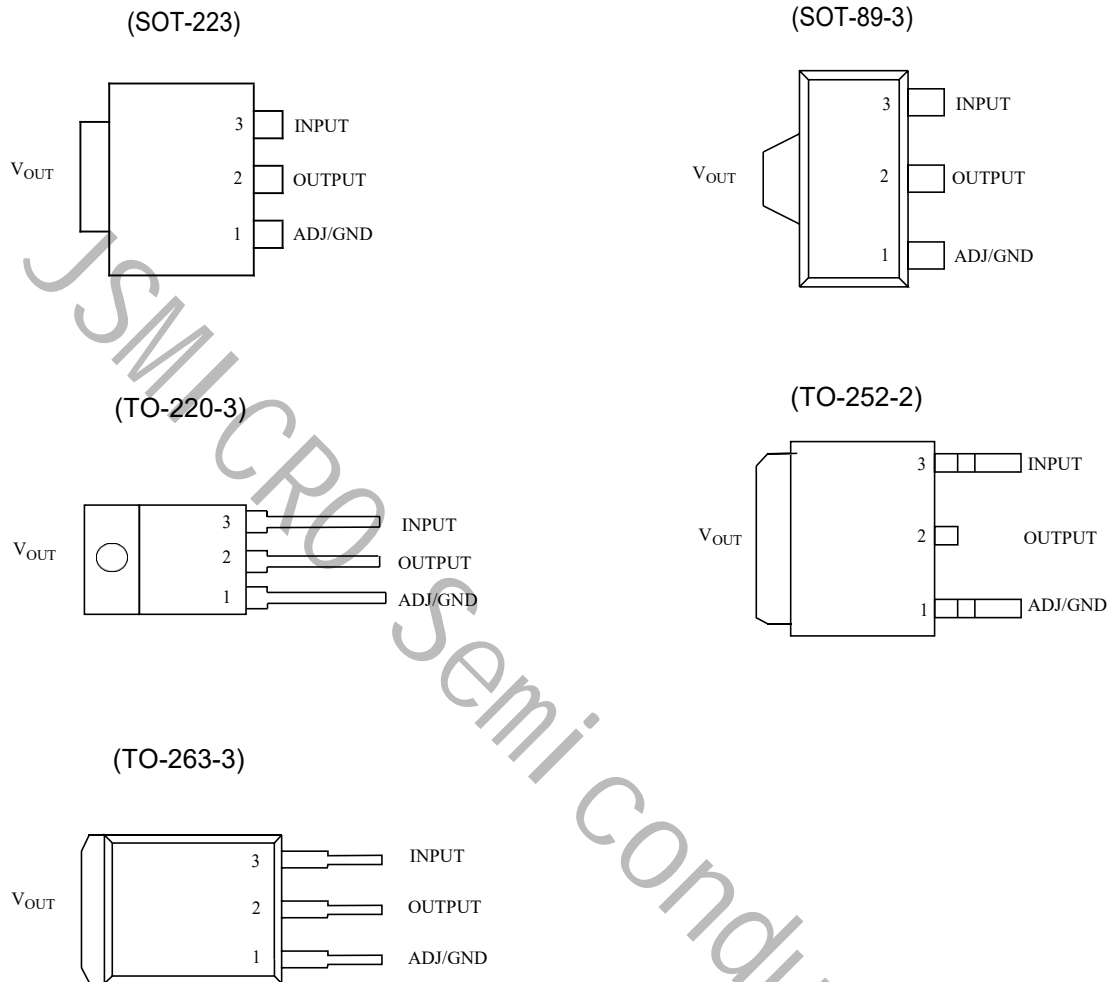

Figure 2. Pin Configuration of LM1117

**Functional Block Diagram**

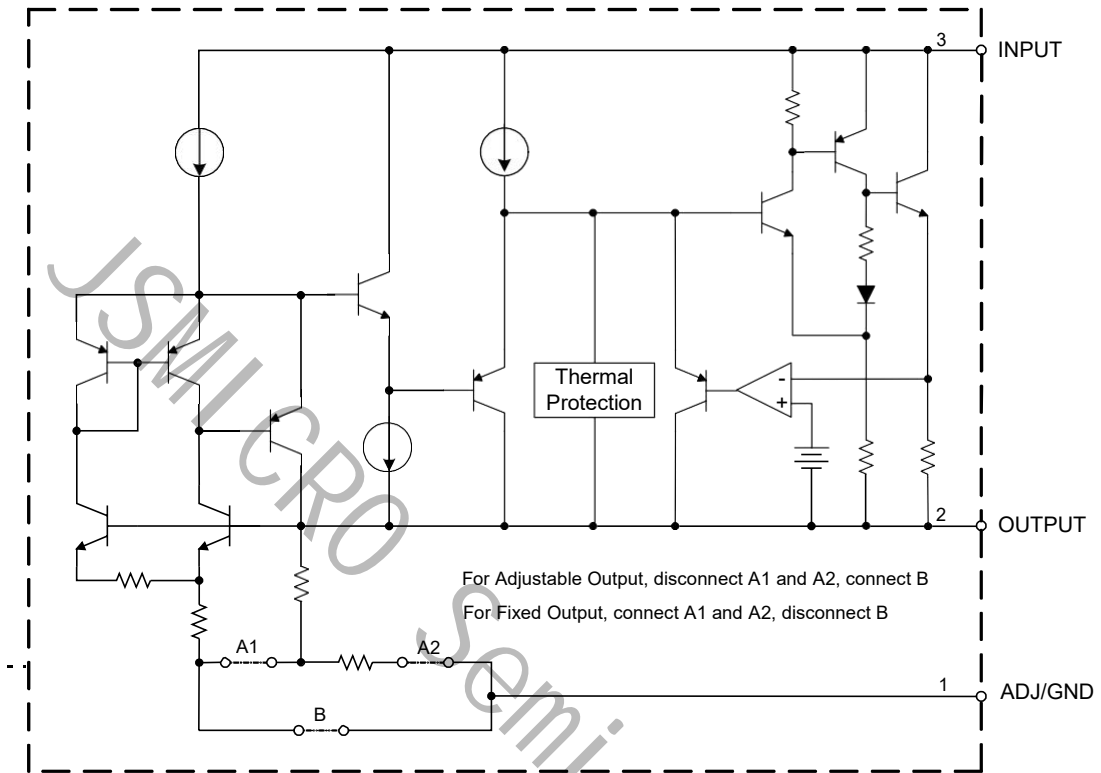
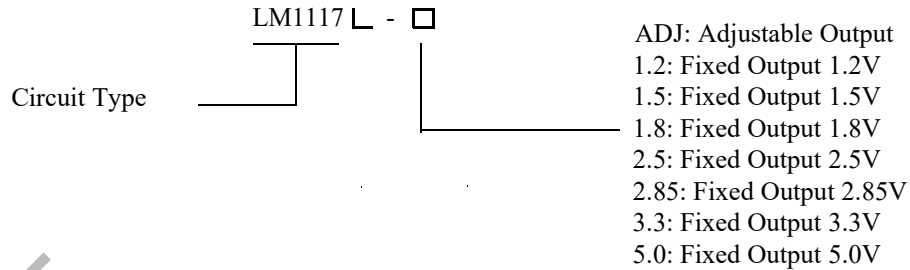

Figure 3. Functional Block Diagram of LM1117

**Ordering Information**

Package	Temperature Range	Part No.	Marking ID	Packing Type
		Tin Lead	Tin Lead	
SOT-223	-40 to 125°C	LM1117-ADJ	1117-ADJ	Tape & Reel
		LM1117-1.2	1117-1.2	Tape & Reel
		LM1117-1.5	1117-1.5	Tape & Reel
		LM1117-1.8	1117-1.8	Tape & Reel
		LM1117-2.5	1117-2.5	Tape & Reel
		LM1117-2.85	1117-2.85	Tape & Reel
		LM1117-3.3	1117-3.3	Tape & Reel
		LM1117-5.0	1117-5.0	Tape & Reel
SOT-89-3	-40 to 125°C	LM1117-ADJ	1117-ADJ	Tape & Reel
		LM1117-1.2	1117-1.2	Tape & Reel
		LM1117-1.5	1117-1.5	Tape & Reel
		LM1117-1.8	1117-1.8	Tape & Reel
		LM1117-2.5	1117-2.5	Tape & Reel
		LM1117-2.85	1117-2.85	Tape & Reel
		LM1117-3.3	1117-3.3	Tape & Reel
		LM1117-5.0	1117-5.0	Tape & Reel
TO-220-3	-40 to 125°C	LM1117T-ADJ	LM1117T-ADJ	Tube
		LM1117T-1.2	LM1117T-1.2	Tube
		LM1117T-1.5	LM1117T-1.5	Tube
		LM1117T-1.8	LM1117T-1.8	Tube
		LM1117T-2.5	LM1117T-2.5	Tube
		LM1117T-2.85	LM1117T-2.85	Tube
		LM1117T-3.3	LM1117T-3.3	Tube
		LM1117T-5.0	LM1117T-5.0	Tube

**Ordering Information (Continued)**

Package	Temperature Range	Part Number	Marking ID	Packing Type
		<b>Tin Lead</b>	<b>Tin Lead</b>	
TO-252-2	-40 to 125°C	LM1117-ADJ	LM1117-ADJ	Tube
		LM1117-ADJ	LM1117-ADJ	Tape & Reel
		LM1117-1.2	LM1117-1.2	Tube
		LM1117-1.2	LM1117-1.2	Tape & Reel
		LM1117-1.5	LM1117-1.5	Tube
		LM1117-1.5	LM1117-1.5	Tape & Reel
		LM1117-1.8	LM1117-1.8	Tube
		LM1117-1.8	LM1117-1.8	Tape & Reel
		LM1117-2.5	LM1117-2.5	Tube
		LM1117-2.5	LM1117-2.5	Tape & Reel
		LM1117-2.85	LM1117-2.85	Tube
		LM1117-2.85	LM1117-2.85	Tape & Reel
		LM1117-3.3	LM1117-3.3	Tube
		LM1117-3.3	LM1117-3.3	Tape & Reel
		LM1117-5.0	LM1117-5.0	Tube
		LM1117-5.0	LM1117-5.0	Tape & Reel
TO-263-3	-40 to 125°C	LM1117-ADJ	LM1117-ADJ	Tube
		LM1117-ADJ	LM1117-ADJ	Tape & Reel
		LM1117-1.2	LM1117-1.2	Tube
		LM1117-1.2	LM1117-1.2	Tape & Reel
		LM1117-1.5	LM1117-1.5	Tube
		LM1117-1.5	LM1117-1.5	Tape & Reel
		LM1117-1.8	LM1117-1.8	Tube
		LM1117-1.8	LM1117-1.8	Tape & Reel
		LM1117-2.5	LM1117-2.5	Tube
		LM1117-2.5	LM1117-2.5	Tape & Reel
		LM1117-2.85	LM1117-2.85	Tube
		LM1117-2.85	LM1117-2.85	Tape & Reel
		LM1117-3.3	LM1117-3.3	Tube
		LM1117-3.3	LM1117-3.3	Tape & Reel
		LM1117-5.0	LM1117-5.0	Tube
		LM1117-5.0	LM1117-5.0	Tape & Reel

**Absolute Maximum Ratings (Note 1)**

Parameter	Symbol	Min	Max	Unit
Input Voltage	$V_{IN}$		20	V
Maximum Junction Temperature	$T_J$		150	°C
Storage Temperature	$T_S$	-65	150	°C
Lead Temperature (Soldering, 10sec)	$T_{LEAD}$		300	°C
ESD (Machine Model)	ESD		600	V

**Recommended Operating Conditions**

Parameter	Symbol	Min	Max	Unit
Input Voltage	$V_{IN}$		15	V
Operating Junction Temperature Range	$T_J$	-40	125	°C

## Electrical Characteristics

### LM1117-ADJ Electrical Characteristics

Operating Conditions:  $V_{IN} \leq 10V$ ,  $T_J = 25^\circ C$ , unless otherwise specified.

Parameter	Symbol	Conditions	Min	Typ	Max	Unit
Reference Voltage	$V_{REF}$	$I_{OUT} = 10mA$ , $V_{IN} - V_{OUT} = 2V$ $10mA \leq I_{OUT} \leq 1A$ , $1.4V \leq V_{IN} - V_{OUT} \leq 8V$ , $P \leq$ Maximum Power Dissipation	1.238 1.225	1.250 1.250	1.262 1.270	V
Line Regulation	$\Delta V_{OUT}$	$I_{OUT} = 10mA$ , $1.5V \leq V_{IN} - V_{OUT} \leq 10V$		0.035	0.2	%
Load Regulation	$\Delta V_{OUT}$	$V_{IN} - V_{OUT} = 2V$ , $10mA \leq I_{OUT} \leq 1A$		0.2	0.4	%
Dropout Voltage		$\Delta V_{REF} = 1\%$ , $I_{OUT} = 0.1A$		1.00	1.1	V
		$\Delta V_{REF} = 1\%$ , $I_{OUT} = 0.5A$		1.08	1.18	V
		$\Delta V_{REF} = 1\%$ , $I_{OUT} = 1.0A$		1.15	1.25	V
Current Limit	$I_{LIMIT}$	$V_{IN} - V_{OUT} = 2V$	1.25	1.35		A
Adjust Pin Current				60	120	$\mu A$
Adjust Pin Current Change		$1.4V \leq V_{IN} - V_{OUT} \leq 10V$ , $10mA \leq I_{OUT} \leq 1A$		0.2	5	$\mu A$
Minimum Load Current (ADJ)		$1.5V \leq V_{IN} - V_{OUT} \leq 10V$ (ADJ only)		1.7	5	mA
Quiescent Current		$V_{IN} = V_{OUT} + 1.25V$		5	10	mA
Ripple Rejection		$f = 120Hz$ , $C_{OUT} = 22\mu F$ Tantalum, $V_{IN} - V_{OUT} = 3V$ , $I_{OUT} = 1A$	60	75		dB
Temperature Stability				0.5		%
Long -Term Stability		$T_A = 125^\circ C$ , 1000hrs		0.3		%
RMS Output Noise (% of $V_{OUT}$ )		$T_A = 25^\circ C$ , $10Hz \leq f \leq 10kHz$		0.003		%
Thermal Resistance, Junction to Case	$\theta_{JC}$	SOT-223 SOT-89-3 TO-252-2 TO-220-3 TO-263-3		15 75 10 4.5 4		$^\circ C/W$
Thermal Shutdown		Junction Temperature		150		$^\circ C$
Thermal Shutdown Hysteresis				25		$^\circ C$

**Electrical Characteristics (Continued)**
**LM1117-1.2V Electrical Characteristics**

Operating Conditions:  $V_{IN} \leq 10V$ ,  $T_J = 25^\circ C$ , unless otherwise specified.

Parameter	Symbol	Conditions	Min	Typ	Max	Unit
Output Voltage	$V_{OUT}$	$I_{OUT} = 10mA$ , $V_{IN} = 3.2V$ $10mA \leq I_{OUT} \leq 1A$ , $3.0V \leq V_{IN} \leq 10V$	1.176 1.152	1.2 1.2	1.224 1.248	V
Line Regulation	$\Delta V_{OUT}$	$I_{OUT} = 10mA$ , $1.5V \leq V_{IN} - V_{OUT} \leq 10V$		1	6	mV
Load Regulation	$\Delta V_{OUT}$	$V_{IN} - V_{OUT} = 2V$ , $10mA \leq I_{OUT} \leq 1A$		1	10	mV
Dropout Voltage		$\Delta V_{OUT} = 1\%$ , $I_{OUT} = 0.1A$		1.00	1.1	V
		$\Delta V_{OUT} = 1\%$ , $I_{OUT} = 0.5A$		1.08	1.18	V
		$\Delta V_{OUT} = 1\%$ , $I_{OUT} = 1.0A$		1.15	1.25	V
Current Limit	$I_{LIMIT}$	$V_{IN} - V_{OUT} = 2V$	1.25	1.35		A
Quiescent Current		$V_{IN} = V_{OUT} + 1.25V$		5	10	mA
Ripple Rejection		$f = 120Hz$ , $C_{OUT} = 22\mu F$ Tantalum, $V_{IN} - V_{OUT} = 3V$ , $I_{OUT} = 1A$	60	75		dB
Temperature Stability				0.5		%
Long -Term Stability		$T_A = 125^\circ C$ , 1000hrs		0.3		%
RMS Output Noise (% of $V_{OUT}$ )		$T_A = 25^\circ C$ , $10Hz \leq f \leq 10kHz$		0.003		%
Thermal Resistance, Junction to Case	$\theta_{JC}$	SOT-223 SOT-89-3 TO-252-2 TO-220-3 TO-263-3		15 75 10 4.5 4		$^\circ C/W$
Thermal Shutdown		Junction Temperature		150		$^\circ C$
Thermal Shutdown Hysteresis				25		$^\circ C$



**Electrical Characteristics (Continued)**  
**LM1117-1.5V Electrical Characteristics**

 Operating Conditions:  $V_{IN} \leq 10V$ ,  $T_J = 25^\circ C$ , unless otherwise specified.

Parameter	Symbol	Conditions	Min	Typ	Max	Unit
Output Voltage	$V_{OUT}$	$I_{OUT} = 10mA$ , $V_{IN} = 3.5V$ $10mA \leq I_{OUT} \leq 1A$ , $3.0V \leq V_{IN} \leq 10V$	1.485 1.470	1.5 1.5	1.515 1.530	V
Line Regulation	$\Delta V_{OUT}$	$I_{OUT} = 10mA$ , $1.5V \leq V_{IN} - V_{OUT} \leq 10V$		1	6	mV
Load Regulation	$\Delta V_{OUT}$	$V_{IN} - V_{OUT} = 2V$ , $10mA \leq I_{OUT} \leq 1A$		1	10	mV
Dropout Voltage		$\Delta V_{OUT} = 1\%$ , $I_{OUT} = 0.1A$		1.00	1.1	V
		$\Delta V_{OUT} = 1\%$ , $I_{OUT} = 0.5A$		1.08	1.18	V
		$\Delta V_{OUT} = 1\%$ , $I_{OUT} = 1.0A$		1.15	1.25	V
Current Limit	$I_{LIMIT}$	$V_{IN} - V_{OUT} = 2V$	1.25	1.35		A
Quiescent Current		$V_{IN} = V_{OUT} + 1.25V$		5	10	mA
Ripple Rejection		$f = 120Hz$ , $C_{OUT} = 22\mu F$ Tantalum, $V_{IN} - V_{OUT} = 3V$ , $I_{OUT} = 1A$	60	75		dB
Temperature Stability				0.5		%
Long -Term Stability		$T_A = 125^\circ C$ , 1000hrs		0.3		%
RMS Output Noise (% of $V_{OUT}$ )		$T_A = 25^\circ C$ , $10Hz \leq f \leq 10kHz$		0.003		%
Thermal Resistance, Junction to Case	$\theta_{JC}$	SOT-223 SOT-89-3 TO-252-2 TO-220-3 TO-263-3		15 75 10 4.5 4		$^\circ C/W$
Thermal Shutdown		Junction Temperature		150		$^\circ C$
Thermal Shutdown Hysteresis				25		$^\circ C$

**Electrical Characteristics (Continued)**  
**LM1117-1.8V Electrical Characteristics**

 Operating Conditions:  $V_{IN} \leq 10V$ ,  $T_J = 25^\circ C$ , unless otherwise specified.

Parameter	Symbol	Conditions	Min	Typ	Max	Unit
Output Voltage	$V_{OUT}$	$I_{OUT} = 10mA$ , $V_{IN} = 3.8V$ $10mA \leq I_{OUT} \leq 1A$ , $3.2V \leq V_{IN} \leq 10V$	1.782 1.746	1.8 1.8	1.818 1.854	V
Line Regulation	$\Delta V_{OUT}$	$I_{OUT} = 10mA$ , $1.5V \leq V_{IN} - V_{OUT} \leq 10V$		1	6	mV
Load Regulation	$\Delta V_{OUT}$	$V_{IN} - V_{OUT} = 2V$ , $10mA \leq I_{OUT} \leq 1A$		1	10	mV
Dropout Voltage		$\Delta V_{OUT} = 1\%$ , $I_{OUT} = 0.1A$		1.00	1.1	V
		$\Delta V_{OUT} = 1\%$ , $I_{OUT} = 0.5A$		1.08	1.18	V
		$\Delta V_{OUT} = 1\%$ , $I_{OUT} = 1.0A$		1.15	1.25	V
Current Limit	$I_{LIMIT}$	$V_{IN} - V_{OUT} = 2V$	1.25	1.35		A
Quiescent Current		$V_{IN} = V_{OUT} + 1.25V$		5	10	mA
Ripple Rejection		$f = 120Hz$ , $C_{OUT} = 22\mu F$ Tantalum, $V_{IN} - V_{OUT} = 3V$ , $I_{OUT} = 1A$	60	75		dB
Temperature Stability				0.5		%
Long -Term Stability		$T_A = 125^\circ C$ , 1000hrs		0.3		%
RMS Output Noise (% of $V_{OUT}$ )		$T_A = 25^\circ C$ , $10Hz \leq f \leq 10kHz$		0.003		%
Thermal Resistance, Junction to Case	$\theta_{JC}$	SOT-223 SOT-89-3 TO-252-2 TO-220-3 TO-263-3		15 75 10 4.5 4		$^\circ C/W$
Thermal Shutdown		Junction Temperature		150		$^\circ C$
Thermal Shutdown Hysteresis				25		$^\circ C$

**Electrical Characteristics (Continued)**  
**LM1117-2.5V Electrical Characteristics**

 Operating Conditions:  $V_{IN} \leq 10V$ ,  $T_J = 25^\circ C$ , unless otherwise specified.

Parameter	Symbol	Conditions	Min	Typ	Max	Unit
Output Voltage	$V_{OUT}$	$I_{OUT} = 10mA$ , $V_{IN} = 4.5V$ $10mA \leq I_{OUT} \leq 1A$ , $3.9V \leq V_{IN} \leq 10V$	2.475 2.450	2.5 2.5	2.525 2.550	V
Line Regulation	$\Delta V_{OUT}$	$I_{OUT} = 10mA$ , $1.5V \leq V_{IN} - V_{OUT} \leq 10V$		1	6	mV
Load Regulation	$\Delta V_{OUT}$	$V_{IN} - V_{OUT} = 2V$ , $10mA \leq I_{OUT} \leq 1A$		1	10	mV
Dropout Voltage		$\Delta V_{OUT} = 1\%$ , $I_{OUT} = 0.1A$		1.00	1.1	V
		$\Delta V_{OUT} = 1\%$ , $I_{OUT} = 0.5A$		1.08	1.18	V
		$\Delta V_{OUT} = 1\%$ , $I_{OUT} = 1.0A$		1.15	1.25	V
Current Limit	$I_{LIMIT}$	$V_{IN} - V_{OUT} = 2V$	1.25	1.35		A
Quiescent Current		$V_{IN} = V_{OUT} + 1.25V$		5	10	mA
Ripple Rejection		$f = 120Hz$ , $C_{OUT} = 22\mu F$ Tantalum, $V_{IN} - V_{OUT} = 3V$ , $I_{OUT} = 1A$	60	75		dB
Temperature Stability				0.5		%
Long -Term Stability		$T_A = 125^\circ C$ , 1000hrs		0.3		%
RMS Output Noise (% of $V_{OUT}$ )		$T_A = 25^\circ C$ , $10Hz \leq f \leq 10kHz$		0.003		%
Thermal Resistance, Junction to Case	$\theta_{JC}$	SOT-223 SOT-89-3 TO-252-2 TO-220-3 TO-263-3		15 75 10 4.5 4		$^\circ C/W$
Thermal Shutdown		Junction Temperature		150		$^\circ C$
Thermal Shutdown Hysteresis				25		$^\circ C$

**Electrical Characteristics (Continued)**  
**LM1117-2.85V Electrical Characteristics**

 Operating Conditions:  $V_{IN} \leq 10V$ ,  $T_J = 25^\circ C$ , unless otherwise specified.

Parameter	Symbol	Conditions	Min	Typ	Max	Unit
Output Voltage	$V_{OUT}$	$I_{OUT} = 10mA$ , $V_{IN} = 4.85V$ $10mA \leq I_{OUT} \leq 1A$ , $4.25V \leq V_{IN} \leq 10V$	2.822 2.793	2.85 2.85	2.878 2.907	V
Line Regulation	$\Delta V_{OUT}$	$I_{OUT} = 10mA$ , $1.5V \leq V_{IN} - V_{OUT} \leq 10V$		1	6	mV
Load Regulation	$\Delta V_{OUT}$	$V_{IN} - V_{OUT} = 2V$ , $10mA \leq I_{OUT} \leq 1A$		1	10	mV
Dropout Voltage		$\Delta V_{REF} = 1\%$ , $I_{OUT} = 0.1A$		1.00	1.1	V
		$\Delta V_{REF} = 1\%$ , $I_{OUT} = 0.5A$		1.08	1.18	V
		$\Delta V_{REF} = 1\%$ , $I_{OUT} = 1.0A$		1.15	1.25	V
Current Limit	$I_{LIMIT}$	$V_{IN} - V_{OUT} = 2V$	1.25	1.35		A
Quiescent Current		$V_{IN} = V_{OUT} + 1.25V$		5	10	mA
Ripple Rejection		$f = 120Hz$ , $C_{OUT} = 22\mu F$ Tantalum, $V_{IN} - V_{OUT} = 3V$ , $I_{OUT} = 1A$	60	75		dB
Temperature Stability				0.5		%
Long -Term Stability		$T_A = 125^\circ C$ , 1000hrs		0.3		%
RMS Output Noise (% of $V_{OUT}$ )		$T_A = 25^\circ C$ , $10Hz \leq f \leq 10kHz$		0.003		%
Thermal Resistance, Junction to Case	$\theta_{JC}$	SOT-223		15		$^\circ C/W$
		SOT-89-3		75		
		TO-252-2		10		
		TO-220-3		4.5		
		TO-263-3		4		
Thermal Shutdown		Junction Temperature		150		$^\circ C$
Thermal Shutdown Hysteresis				25		$^\circ C$

**Electrical Characteristics (Continued)**  
**LM1117-3.3V Electrical Characteristics**

 Operating Conditions:  $V_{IN} \leq 10V$ ,  $T_J = 25^\circ C$ , unless otherwise specified.

Parameter	Symbol	Conditions	Min	Typ	Max	Unit
Output Voltage	$V_{OUT}$	$I_{OUT} = 10mA$ , $V_{IN} = 5.0V$ $10mA \leq I_{OUT} \leq 1A$ , $4.75V \leq V_{IN} \leq 10V$	3.267 3.235	3.3 3.3	3.333 3.365	V
Line Regulation	$\Delta V_{OUT}$	$I_{OUT} = 10mA$ , $1.5V \leq V_{IN} - V_{OUT} \leq 10V$		1	6	mV
Load Regulation	$\Delta V_{OUT}$	$V_{IN} - V_{OUT} = 2V$ , $10mA \leq I_{OUT} \leq 1A$		1	10	mV
Dropout Voltage		$\Delta V_{OUT} = 1\%$ , $I_{OUT} = 0.1A$		1.00	1.1	V
		$\Delta V_{OUT} = 1\%$ , $I_{OUT} = 0.5A$		1.08	1.18	V
		$\Delta V_{OUT} = 1\%$ , $I_{OUT} = 1.0A$		1.15	1.25	V
Current Limit	$I_{LIMIT}$	$V_{IN} - V_{OUT} = 2V$	1.25	1.35		A
Quiescent Current		$V_{IN} = V_{OUT} + 1.25V$		5	10	mA
Ripple Rejection		$f = 120Hz$ , $C_{OUT} = 22\mu F$ Tantalum, $V_{IN} - V_{OUT} = 3V$ , $I_{OUT} = 1A$	60	75		dB
Temperature Stability				0.5		%
Long -Term Stability		$T_A = 125^\circ C$ , 1000hrs		0.3		%
RMS Output Noise (% of $V_{OUT}$ )		$T_A = 25^\circ C$ , $10Hz \leq f \leq 10kHz$		0.003		%
Thermal Resistance, Junction to Case	$\theta_{JC}$	SOT-223 SOT-89-3 TO-252-2 TO-220-3 TO-263-3		15 75 10 4.5 4		$^\circ C/W$
Thermal Shutdown		Junction Temperature		150		$^\circ C$
Thermal Shutdown Hysteresis				25		$^\circ C$

**Electrical Characteristics (Continued)**  
**LM1117-5.0V Electrical Characteristics**

Operating Conditions:  $V_{IN} \leq 10V$ ,  $T_J = 25^\circ C$ , unless otherwise specified.

Parameter	Symbol	Conditions	Min	Typ	Max	Unit
Output Voltage	$V_{OUT}$	$I_{OUT} = 10mA$ , $V_{IN} = 7.0V$ $10mA \leq I_{OUT} \leq 1A$ , $6.5V \leq V_{IN} \leq 12V$	4.950 4.900	5.0 5.0	5.050 5.100	V
Line Regulation	$\Delta V_{OUT}$	$I_{OUT} = 10mA$ , $1.5V \leq V_{IN} - V_{OUT} \leq 10V$		1	10	mV
Load Regulation	$\Delta V_{OUT}$	$V_{IN} - V_{OUT} = 2V$ , $10mA \leq I_{OUT} \leq 1A$		1	15	mV
Dropout Voltage		$\Delta V_{OUT} = 1\%$ , $I_{OUT} = 0.1A$		1.00	1.1	V
		$\Delta V_{OUT} = 1\%$ , $I_{OUT} = 0.5A$		1.08	1.18	V
		$\Delta V_{OUT} = 1\%$ , $I_{OUT} = 1.0A$		1.15	1.25	V
Current Limit	$I_{LIMIT}$	$V_{IN} - V_{OUT} = 2V$	1.25	1.35		A
Quiescent Current		$V_{IN} = V_{OUT} + 1.25V$		5	10	mA
Ripple Rejection		$f = 120Hz$ , $C_{OUT} = 22\mu F$ Tantalum, $V_{IN} - V_{OUT} = 3V$ , $I_{OUT} = 1A$	60	75		dB
Temperature Stability				0.5		%
Long -Term Stability		$T_A = 125^\circ C$ , 1000hrs		0.3		%
RMS Output Noise (% of $V_{OUT}$ )		$T_A = 25^\circ C$ , $10Hz \leq f \leq 10kHz$		0.003		%
Thermal Resistance, Junction to Case	$\theta_{JC}$	SOT-223 SOT-89-3 TO-252-2 TO-220-3 TO-263-3		15 75 10 4.5 4		$^\circ C/W$
Thermal Shutdown		Junction Temperature		150		$^\circ C$
Thermal Shutdown Hysteresis				25		$^\circ C$

Typical Performance Characteristics

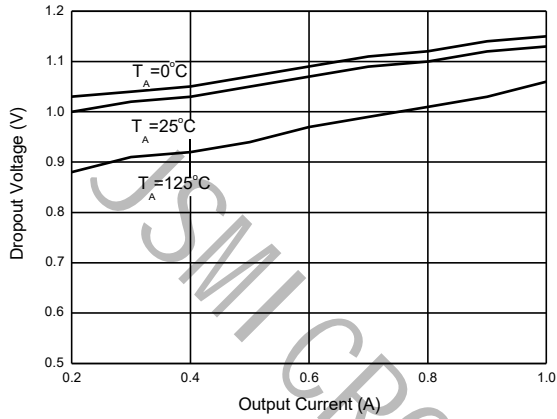

Figure 4. Dropout Voltage vs. Output Current

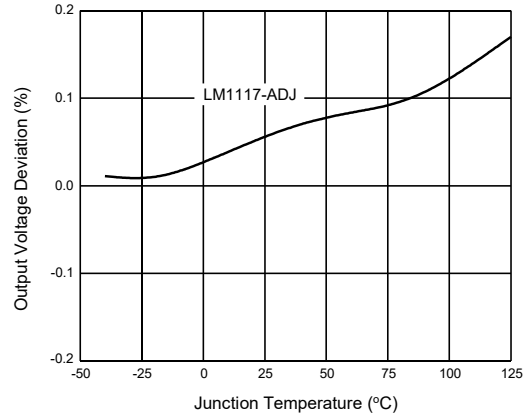

Figure 5. Load Regulation vs. Junction Temperature

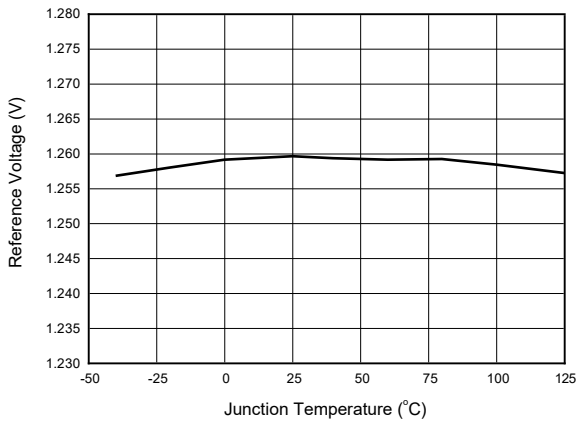

Figure 6. Reference Voltage vs. Junction Temperature

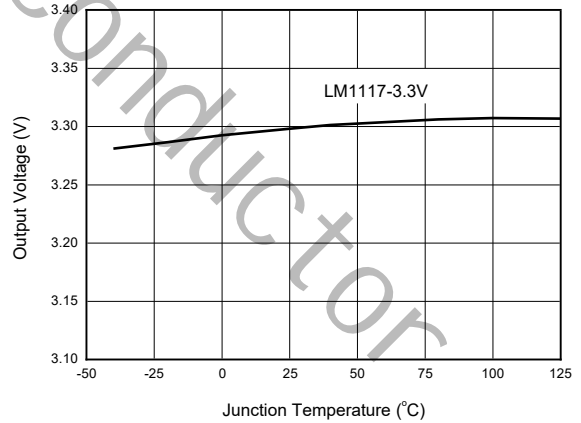

Figure 7. Output Voltage vs. Junction Temperature

Typical Performance Characteristics (Continued)

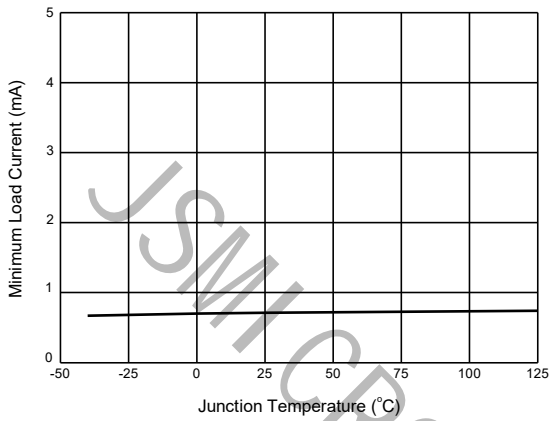

Figure 8. Minimum Load Current vs. Junction Temperature

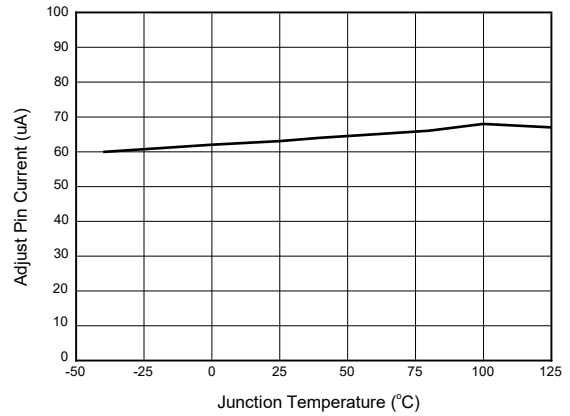

Figure 9. Adjust Pin Current vs. Temperature

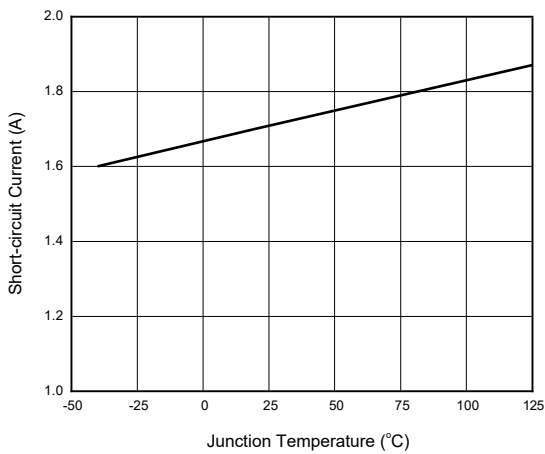

Figure 10. Short-Circuit Current vs. Junction Temperature

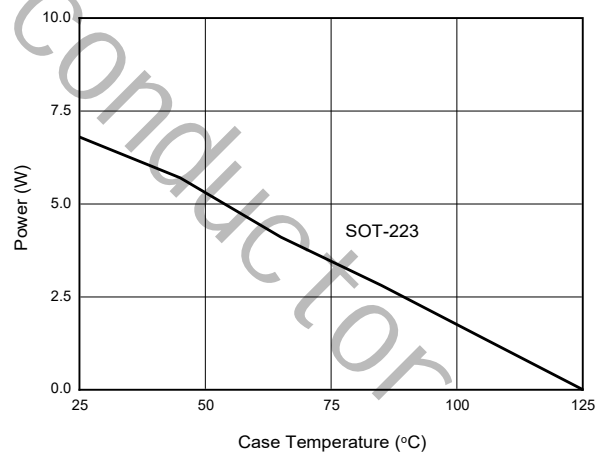

Figure 11. Maximum Power Dissipation



Typical Performance Characteristics (Continued)

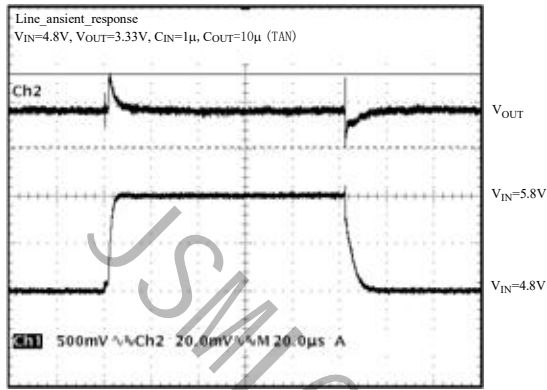

Figure 12. Line transient Response

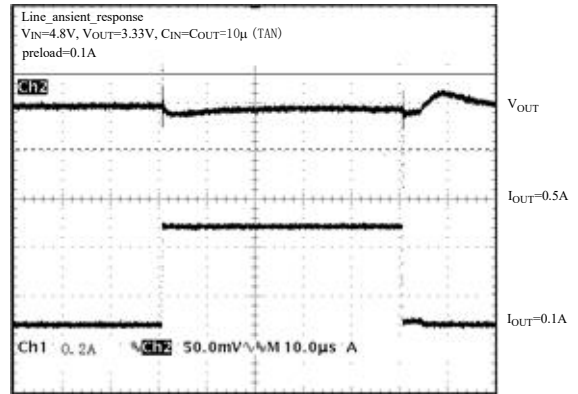

Figure 13. Load transient Response

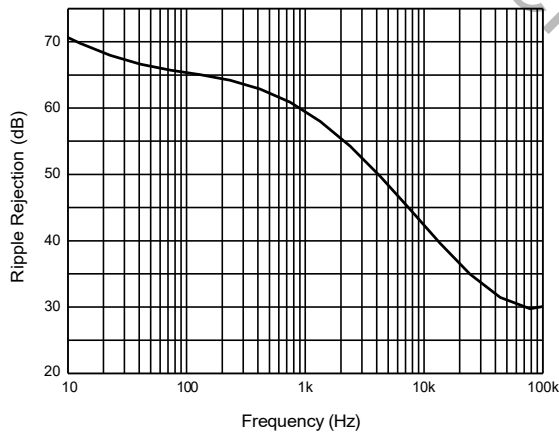

Figure 14. Ripple Rejection vs. Frequency

Typical Applications

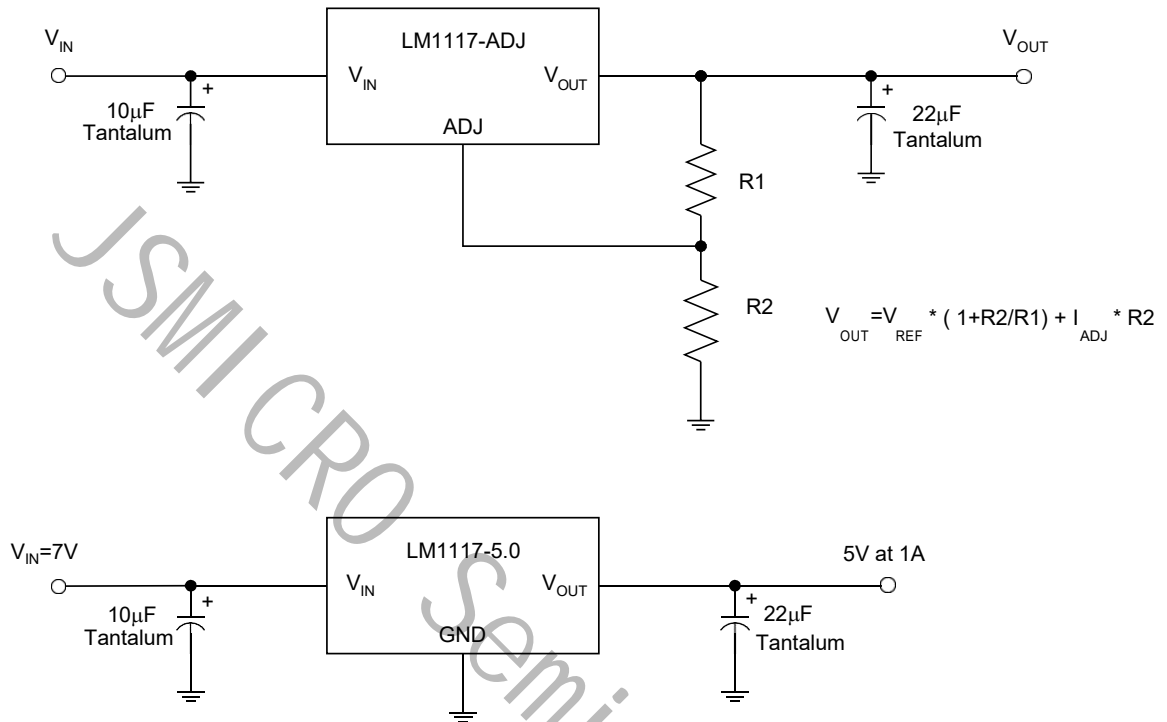
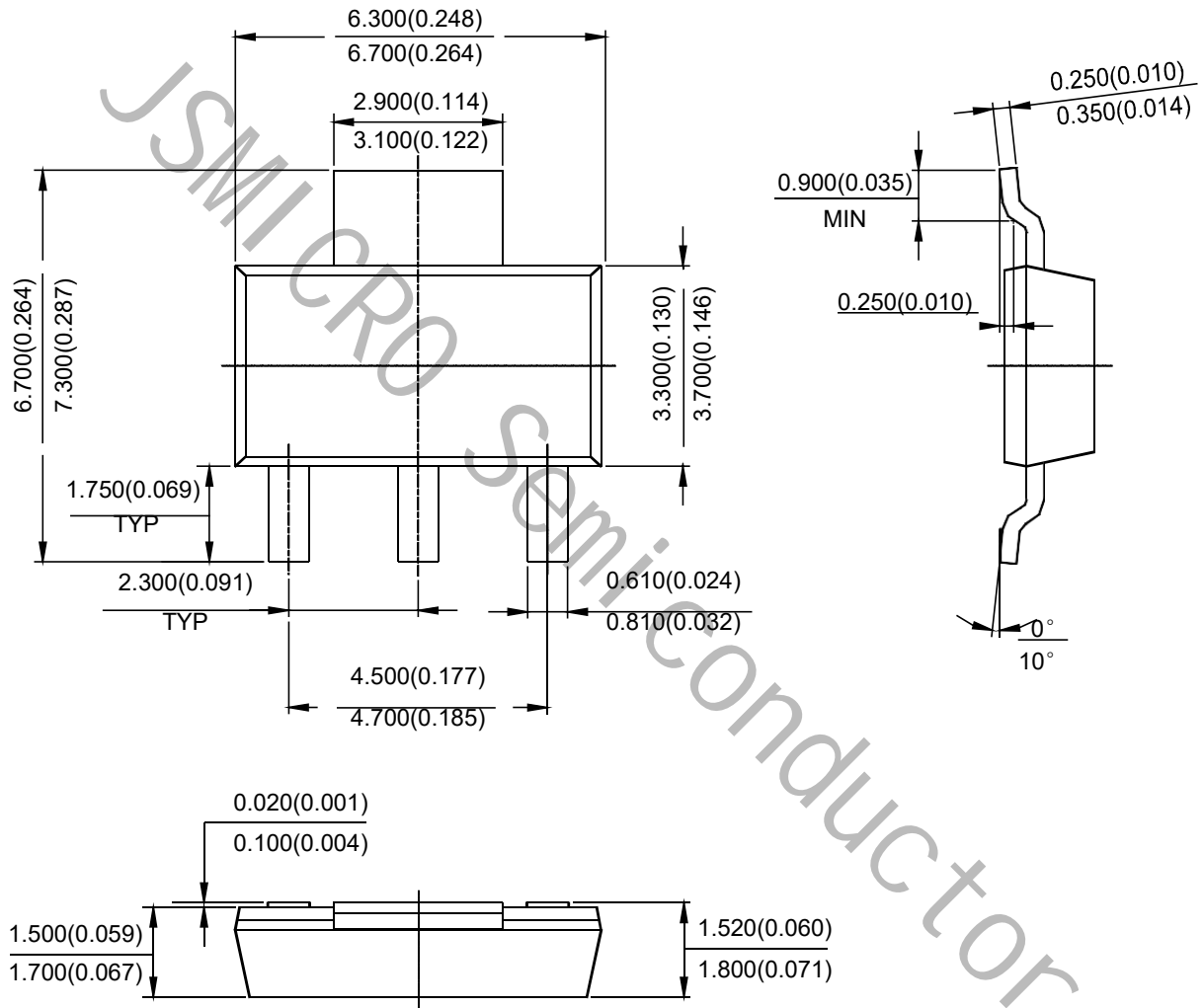

Figure 15. Typical Applications of LM1117

**Mechanical Dimensions**

**SOT-223**

**Unit: mm(inch)**



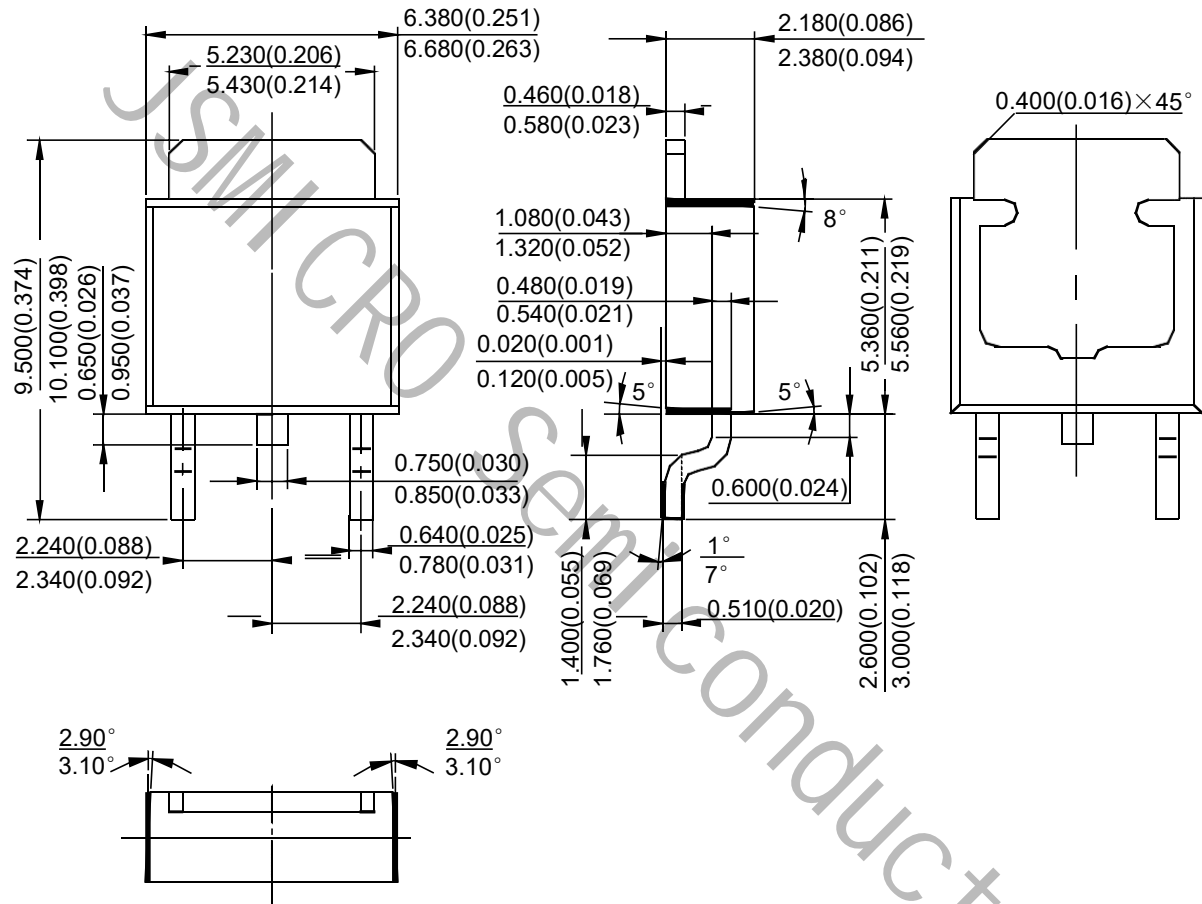

**Mechanical Dimensions (Continued)**
**TO-252-2**
**Unit: mm(inch)**

Mechanical Dimensions (Continued)

TO-220-3

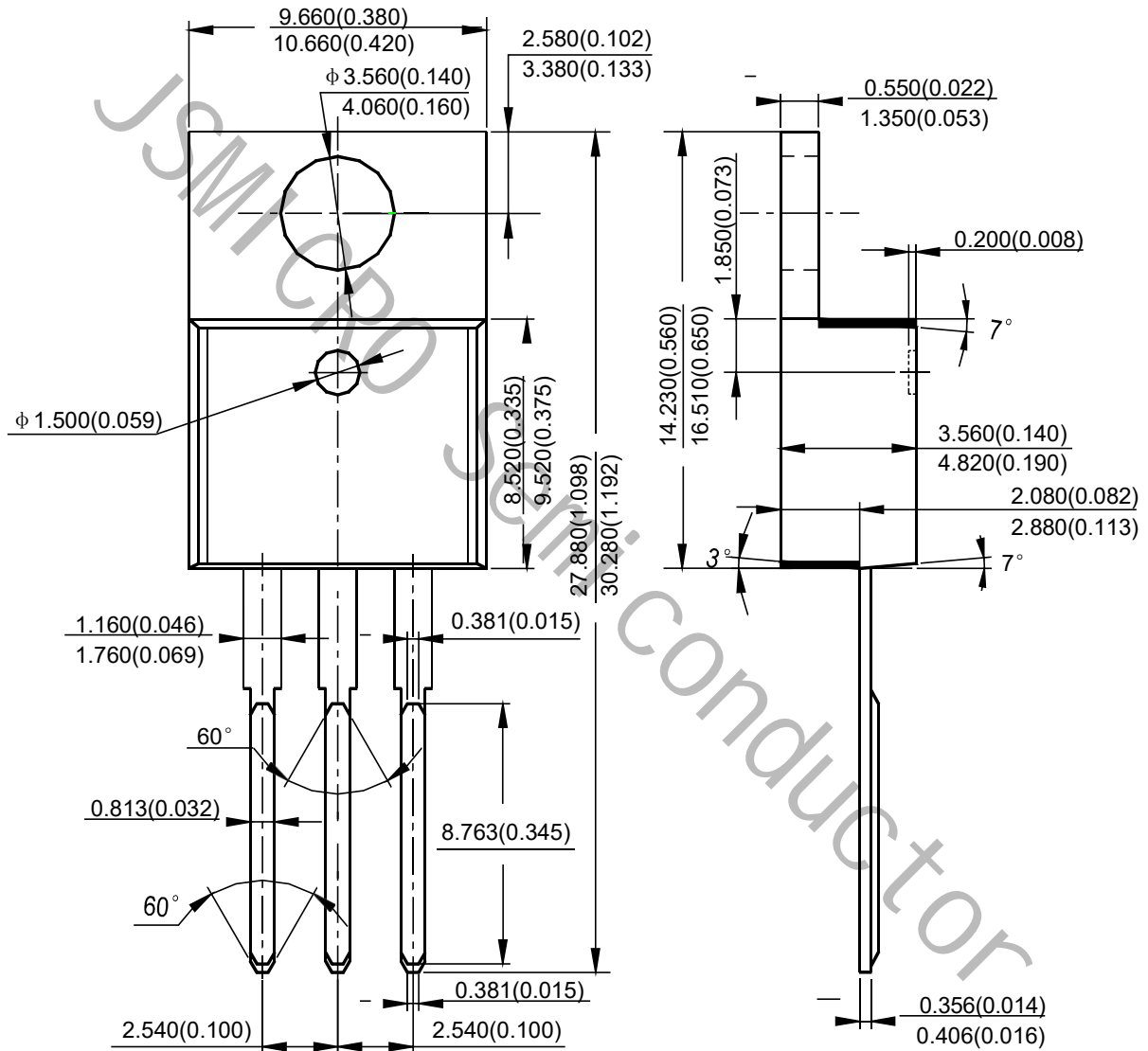

**Mechanical Dimensions (Continued)**

**TO-263-3**

**Unit: mm(inch)**

