

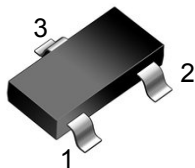
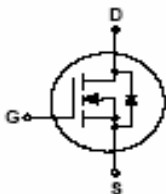

SOT-23

MARKING: A2sHB

Features

Advanced trench process technology
 High density cell design for Ultra Low On-Resistance
 Halogen free and RoHS compliant

Mechanical Data

SOT-23 Small Outline Plastic Package
 EpoxyUL:94V-0

Summary of Packing Options

Package	Packing Description	Packing Quantity	Industry Standard
SOT-23	Tape/Reel, 7" reel	3000	EIA-481-1

Maximum Ratings & Thermal Characteristics

(Ratings at 25°C ambient temperature unless otherwise specified.)

Parameter	Symbol	Limit	Unit	
Drain-Source Voltage	V_{DS}	20	V	
Gate-Source Voltage	V_{GS}	±10		
Continuous Drain Current	I_D	3	A	
Pulsed Drain Current ¹⁾	I_{DM}	12		
Maximum Power Dissipation ²⁾	P_D	TA = 25°	1.25	W
		TA = 75°C	0.8	
Operating Junction and Storage Temperature Range	T_J, T_{stg}	-55 to 150	°C	
Junction-to-Ambient Thermal Resistance (PCB mounted) ²⁾	R_{thJA}	100	°C/W	
Junction-to-Ambient Thermal Resistance (PCB mounted) ³⁾		166		

 Notes ¹⁾ Pulse width limited by maximum junction temperature.

²⁾ Surface Mounted on FR4 Board, $t \leq 5$ sec.

³⁾ Surface Mounted on FR4 Board.

Electrical Characteristics

(Ratings at 25°C ambient temperature unless otherwise specified).

Parameter	Symbol	Test Condition	Min.	Typ.	Max.	Unit
Static						
Drain-Source Breakdown Voltage	BV_{DSS}	$V_{GS} = 0V, I_D = 250\mu A$	20			V
Drain-Source On-State Resistance ¹⁾	$R_{DS(on)}$	$V_{GS} = 4.5V, I_D = 3A$		30	45	mΩ
		$V_{GS} = 2.5V, I_D = 2.5A$		37	59	
Gate Threshold Voltage	$V_{GS(th)}$	$V_{DS} = V_{GS}, I_D = 250\mu A$	0.6		1.5	V
Zero Gate Voltage Drain Current I_0	I_{DSS}	$V_{DS} = 16V, V_{GS} = 0V$		1		μA
		$V_{DS} = 16V, V_{GS} = 0V, T_J = 55^\circ C$			10	
Gate Body Leakage	I_{GSS}	$V_{GS} = \pm 10V, V_{DS} = 0V$			±100	nA
Forward Transconductance ¹⁾	g_{fs}	$V_{DS} = 5V, I_D = 3A$		10	—	S



Electrical Characteristics

(Ratings at 25°C ambient temperature unless otherwise specified).

Parameter	Symbol	Test Condition	Min.	Typ.	Max.	Unit
Dynamic						
Total Gate Charge	Q_g	$V_{DS} = 10V, I_D = 3A$ $V_{GS} = 4.5V$		5.4	10	nC
Gate-Source Charge	Q_{gs}			0.65		
Gate-Drain Charge	Q_{gd}			1.6		
Turn-On Delay Time	$t_{d(on)}$	$V_{DD} = 10V, R_L = 5.5\Omega$ $I_b \cong 3A, V_{GEN} = 4.5V$ $R_G = 6\Omega$		12		ns
Turn-On Rise Time	t_r			36		
Turn-Off Delay Time	$t_{d(off)}$			34		
Turn-Off Fall Time	t_f			10		
Input Capacitance	C_{iss}	$V_{DS} = 10V, V_{GS} = 0V$ $f = 1.0\text{ MHz}$		340		pF
Output Capacitance	C_{oss}			115		
Reverse Transfer Capacitance	C_{rss}			33		
Source-Drain Diode						
Max. Diode Forward Current	I_S				1.6	A
Diode Forward Voltage	V_{SD}	$I_S = 1.0A, V_{GS} = 0V$			1.2	V

1) Pulse test: pulse width $\leq 300\mu s$, duty cycle $\leq 2\%$

Ratings and Characteristic Curves

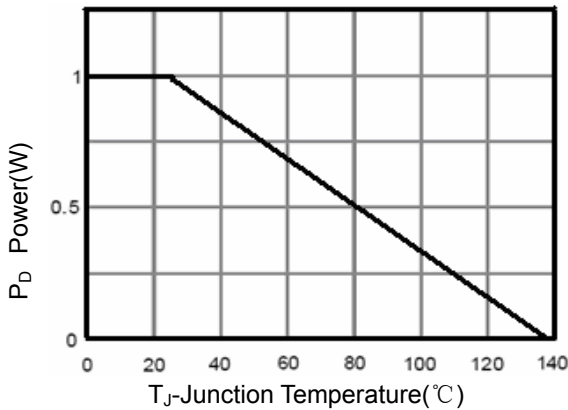

Figure 1 Power Dissipation

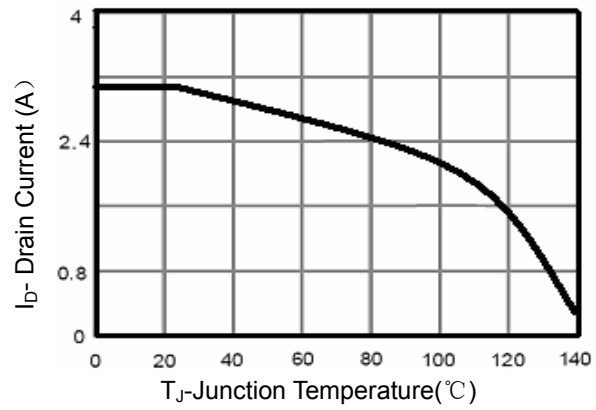

Figure 2 Drain Current

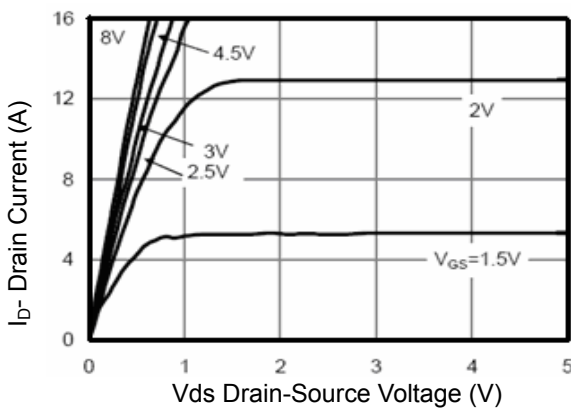

Figure 3 Output Characteristics

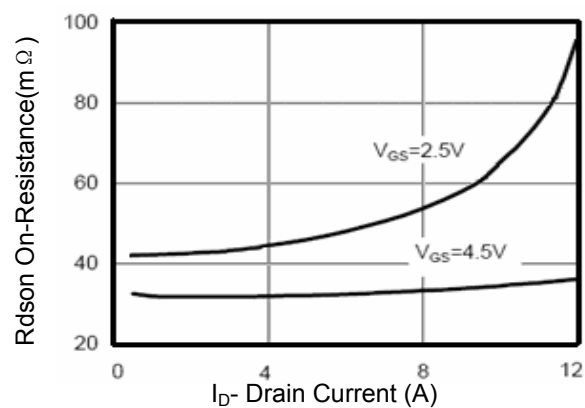

Figure 4 Drain-Source On-Resistance

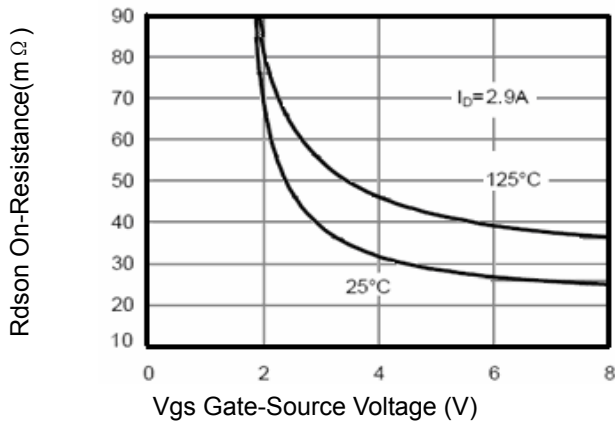

Figure 5 Rdson vs Vgs

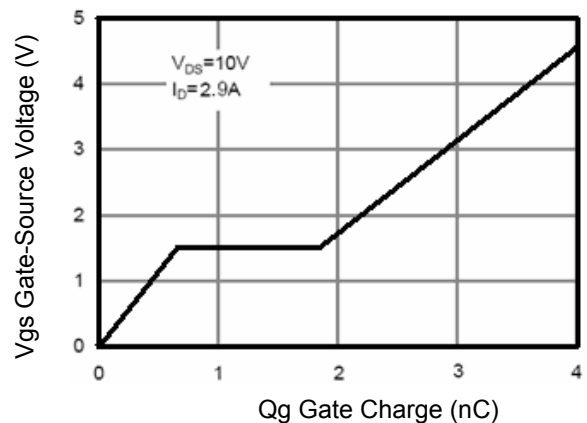

Figure 6 Gate Charge

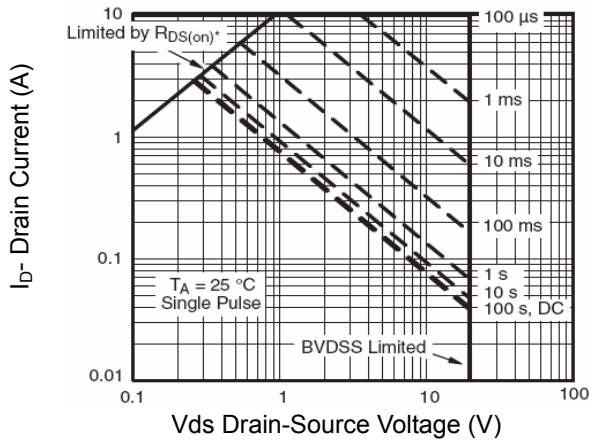
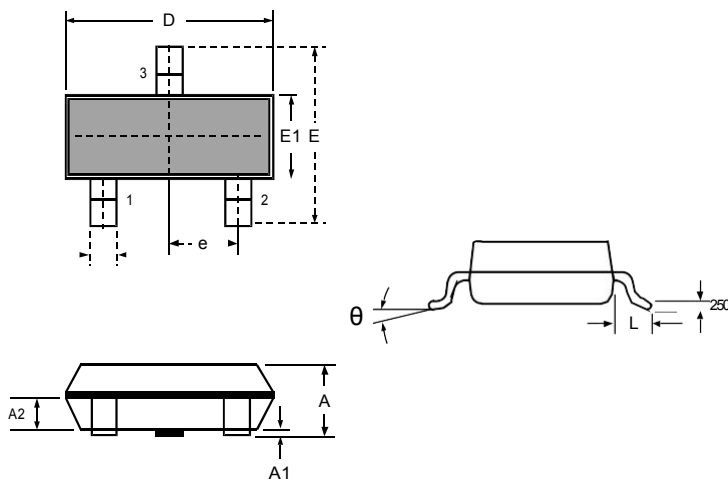

Figure 7 Safe Operation Area

Package Outline Dimensions: SOT-23



DIMENSIONS

SYMBOL	MILLIMETER		INCHES	
	MIN	MAX	MIN	MAX
A	0.900	1.150	0.035	0.045
A1	0.000	0.100	0.000	0.004
A2	0.900	1.050	0.035	0.041
D	2.800	3.000	0.110	0.118
b	0.300	0.500	0.012	0.020
E	2.250	2.550	0.089	0.100
E1	1.200	1.400	0.047	0.055
e	0.950 BSC		0.037 BSC	
L	0.300	0.500	0.012	0.020
θ	0	8°	0	8°