

G-Switch USB-C Specification:

1. Current rated: 3A on vbus/1.25A on vconn/0.25A on other
2. Voltage rating: 5V AC
3. Withstanding voltage: 100V AC/minute
4. Contact resistance: 40mΩ Max
5. Insulation resistance: 100MΩ Min
6. Operating temperature: -40°C ~ +85°C
7. Mating force: 5N~20N
8. Unmating force: 8N~20N
9. Durability cycle: 10,000 cycles
9. Waterproof grade: IP-X7.

A1	A2	A3	A4	A5	A6	A7	A8	A9	A10	A11	A12
				CC1				VBUS			GND
				Second				First			First
B12	B11	B10	B9	B8	B7	B6	B5	B4	B3	B2	B1
GND			VBUS				CC2				
First			First				Second				

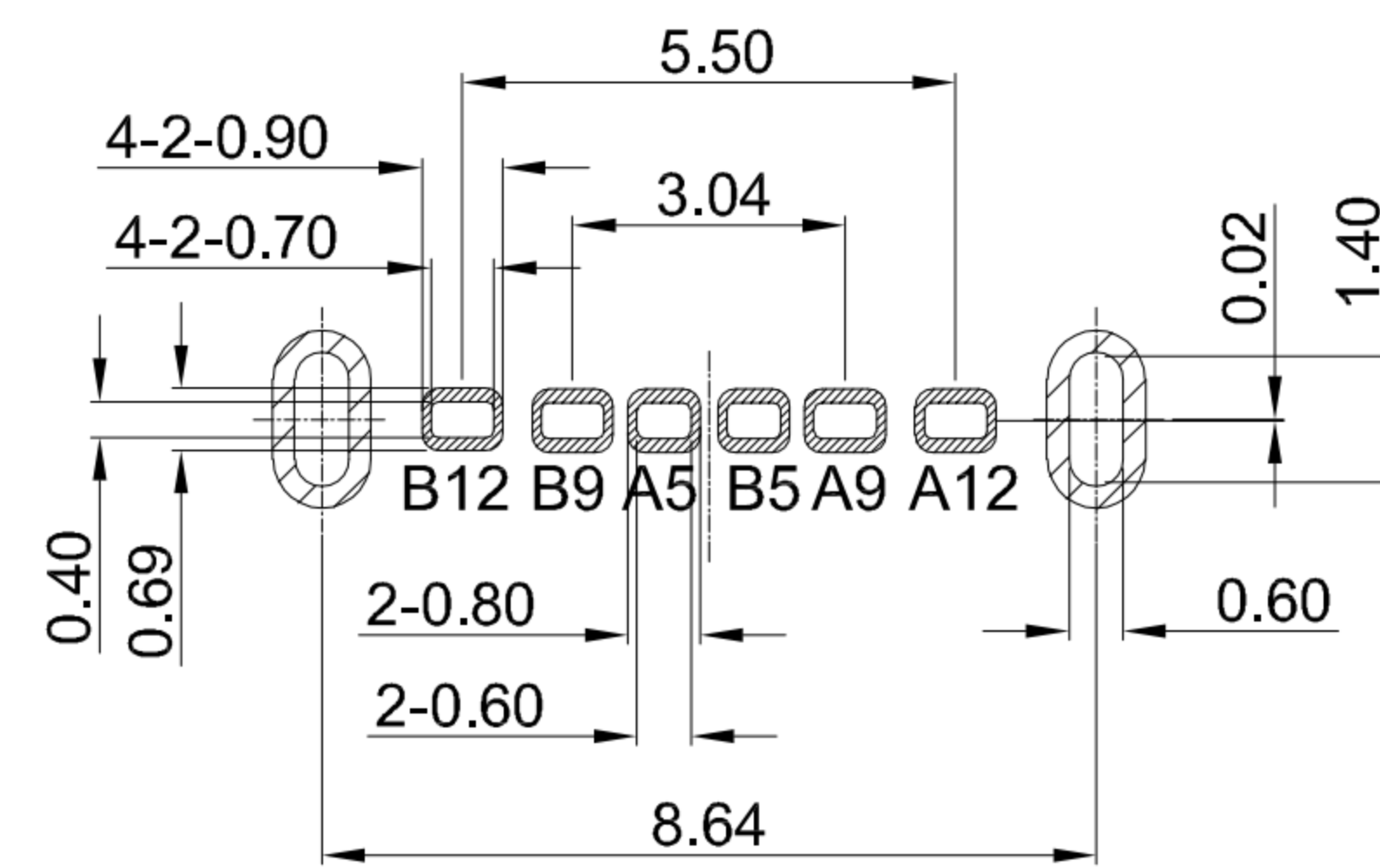
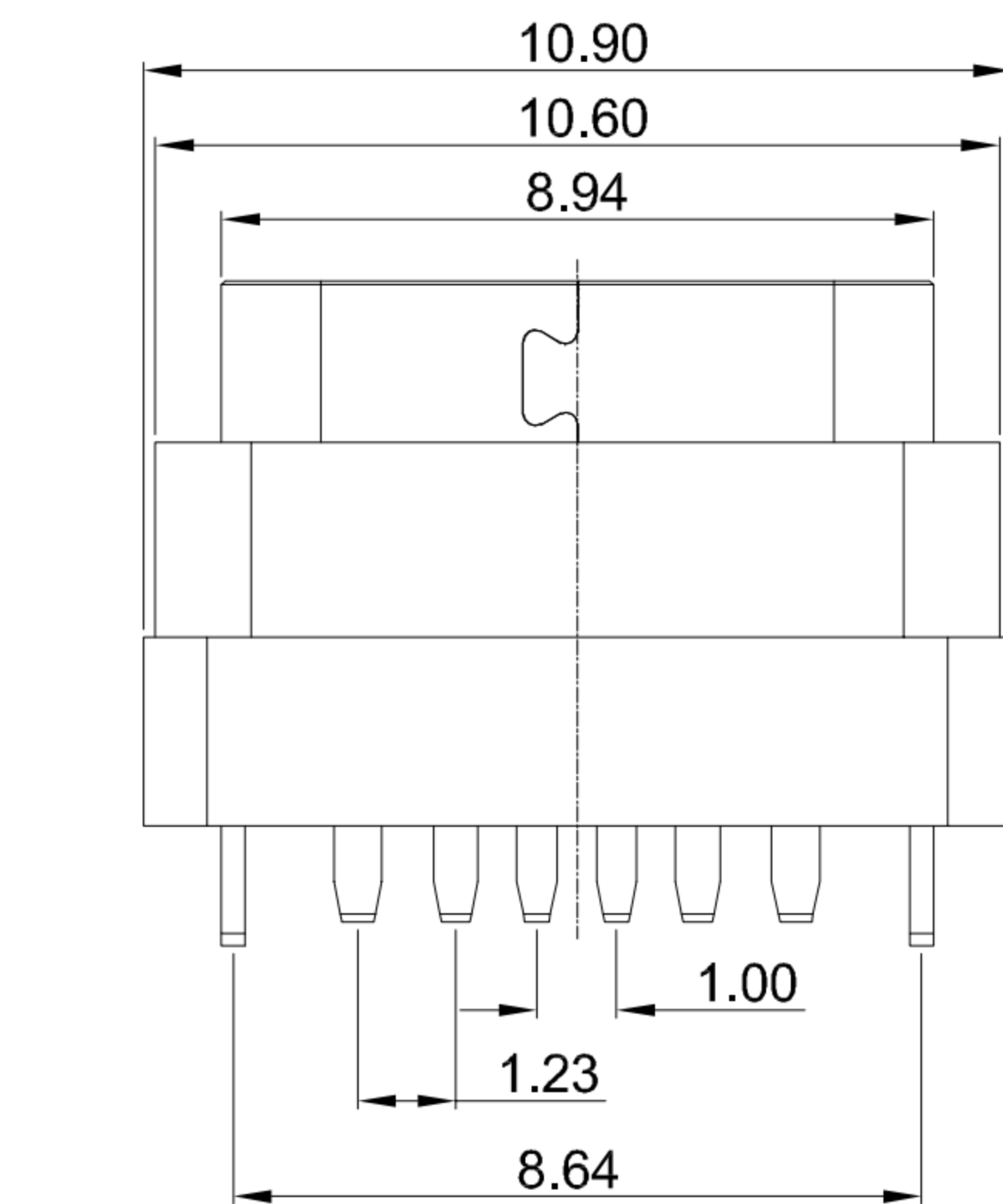
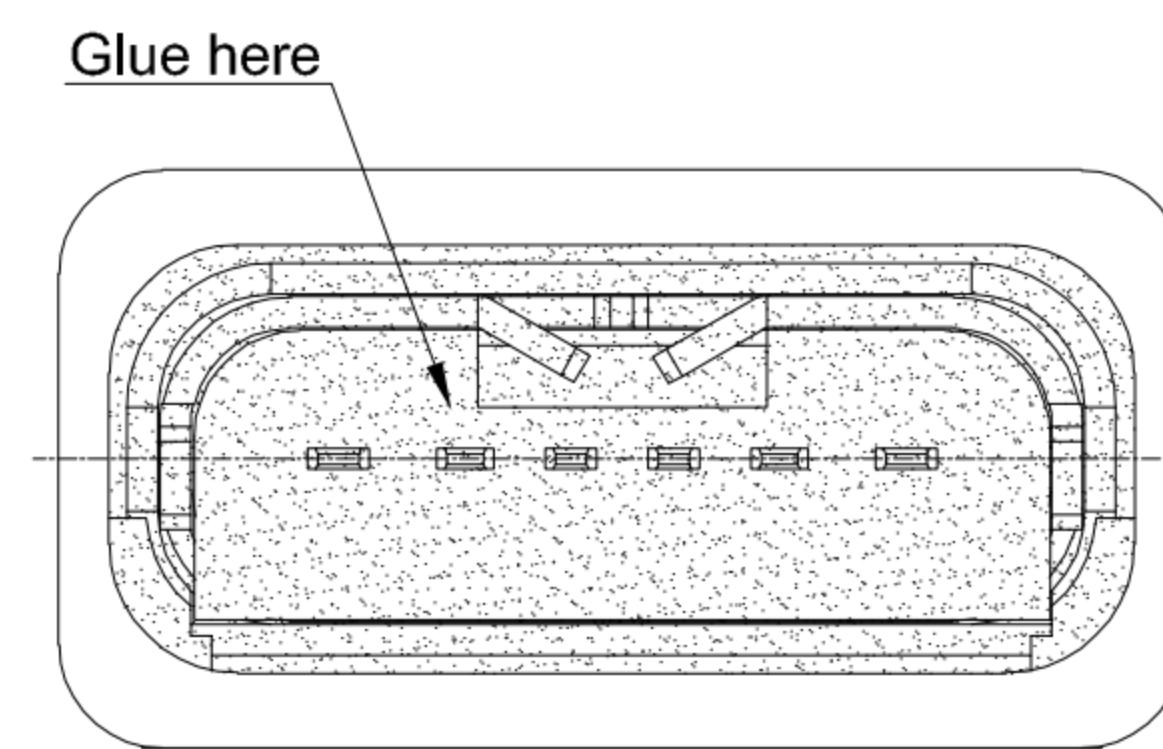
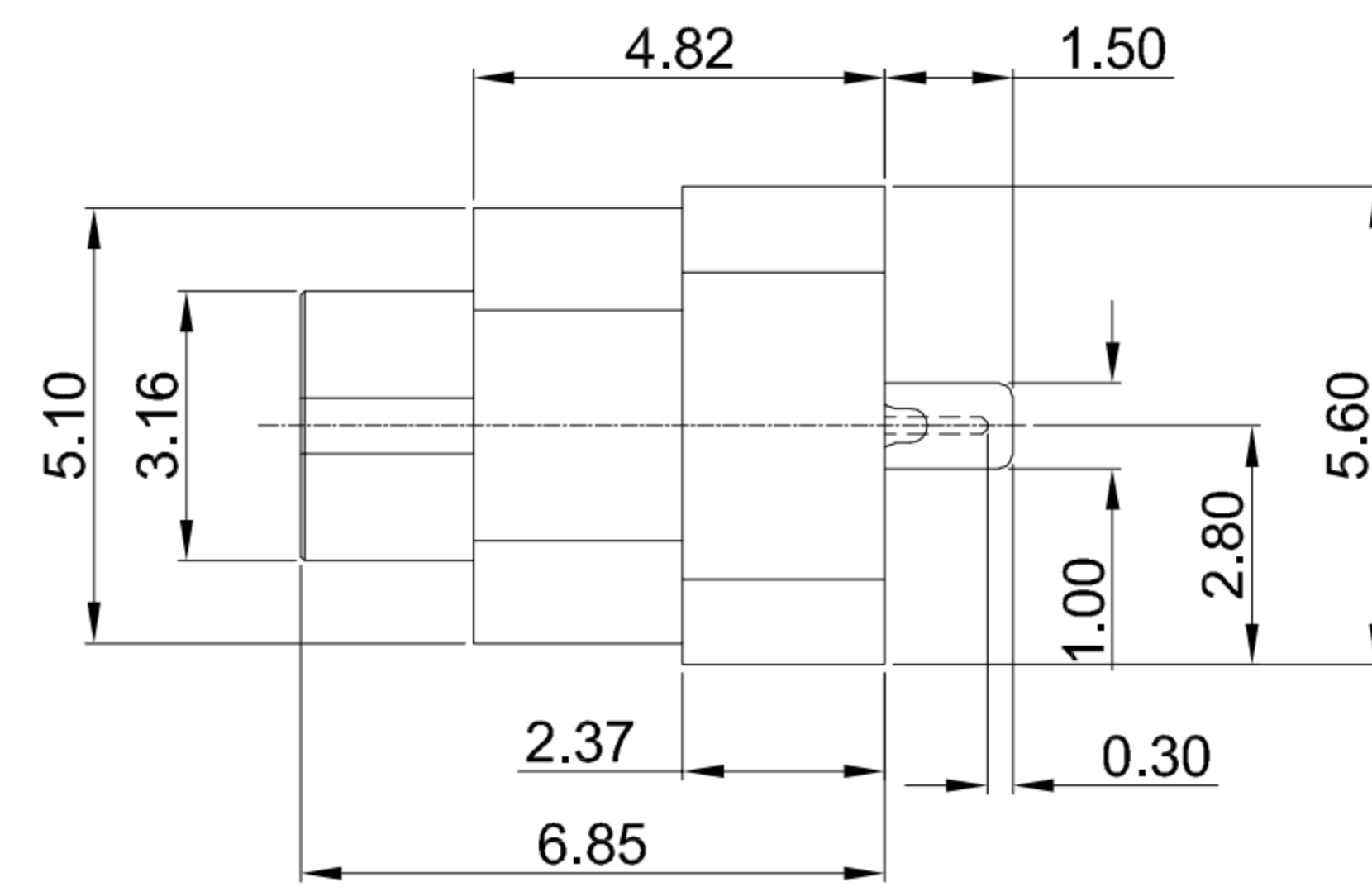
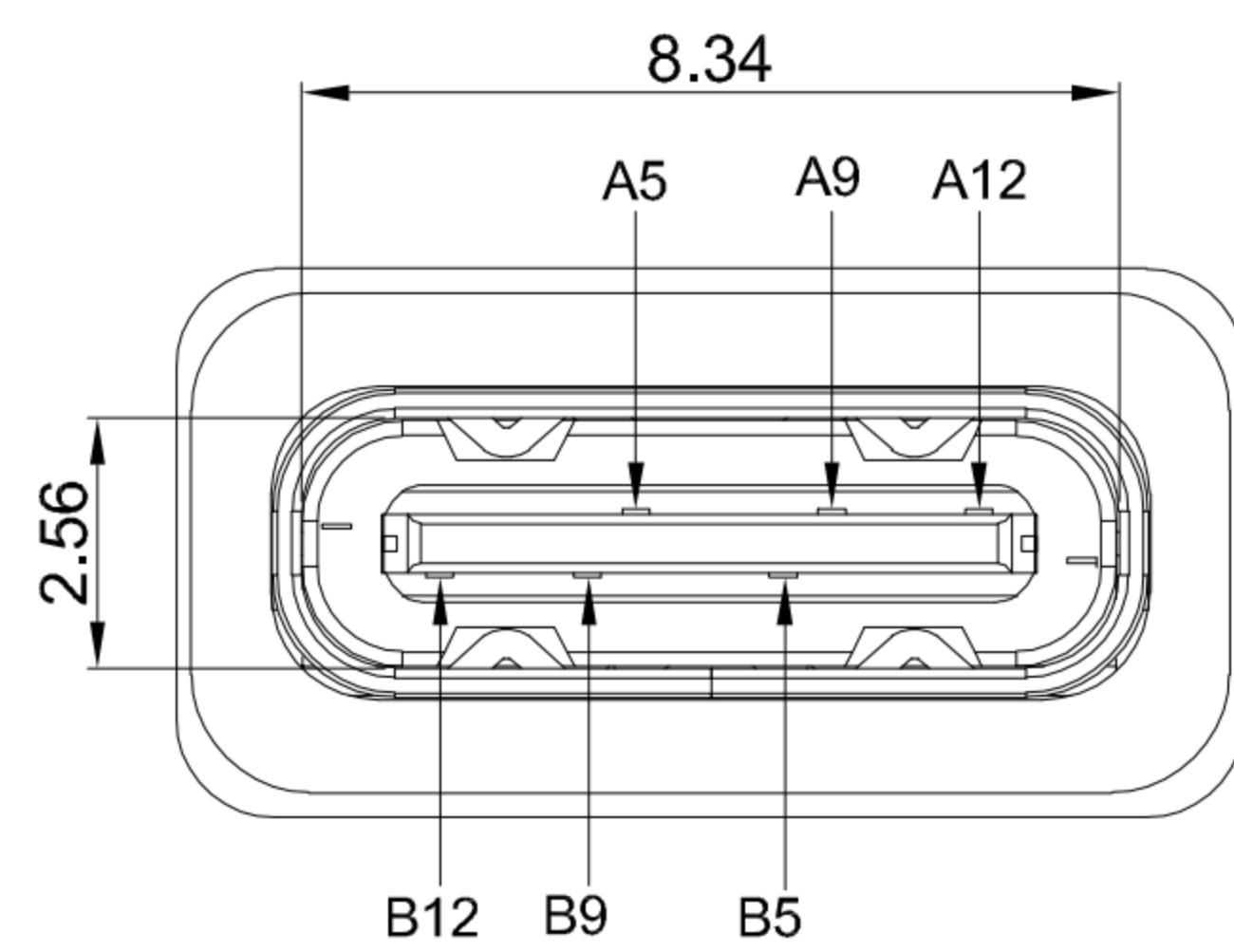

RECOMMENDED PCB LAYOUT
TOLERANCE: ±0.05

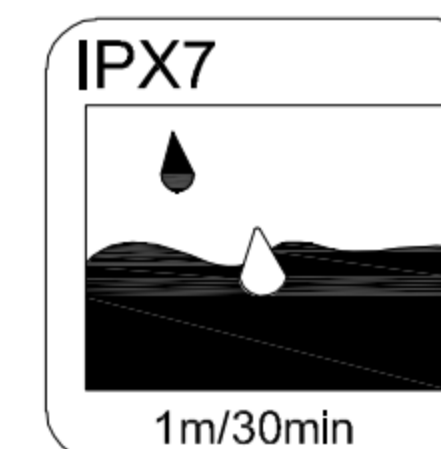

1	WATERPROOF RING	SILICA GEL	BLACK
2	SHEATH	HIGH TEMPERATURE PLASTIC	PA9T BLACK UL 94 V-0
3	SHELL	STAINLESS STEEL	Ni PLATED
4	MID PLATE	STAINLESS STEEL	—
5	HOUSING	HIGH TEMPERATURE PLASTIC	BLACK UL 94 V-0
6	TERMINALS	COPPER ALLOY	Au PLATING ON CONTACT AREA
NO.	PARTS	MATERIAL	REMARKS



SCALE: 1:1 UNIT: mm
SIZE: A4

Unless otherwise
General Tolerance:
X.x ±0.25
X.xx ±0.15
X.xxx ±0.05
X° ±3°

Title: Vertical Type-c 6P Female
DIP H=6.85mm

Molde Code: GT-USB-7076A

DRAWN	CHECKED	APPROVED	DATE
Xia	Chen	Chen	2023.02.31



REV: A0 SHEET: 1/1