

CATEGORY	4	DESCRIPTION	P/N #
CONNECTOR	USB A母直立DIP成品	UB30F-UX11-YP153J	

REV.	ECN NO	DESCRIPTION	REVISED	DATE
A01		New Release	ZSH	2018-6-12
A02		新增电镀规格	XSY	2021-9-16

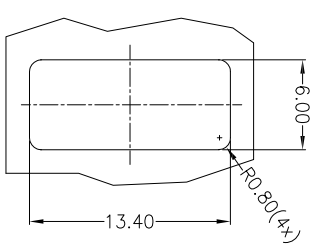
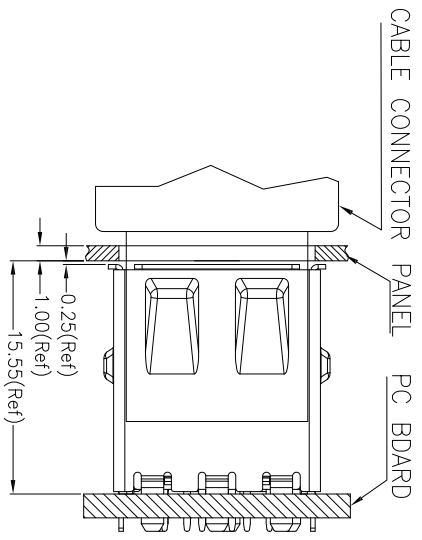
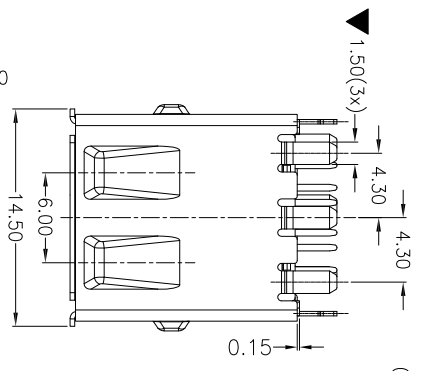
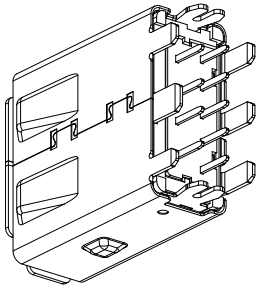

- NOTE:
- 1 MATERIAL:
 - 2 SEE TABLE 1
 - 3 ELECTRICAL CHARACTERISTICS:
 - 2.1 CONTACT RESISTANCE: 30mΩ FOR CONTACT PIN1 & PIN4, 50mΩ FOR ALL OF OTHER CONTACTS, AFTER DURABILITY Δ10mΩ
 - 2.2 CONTACT CURRENT RATING: PIN1 & PIN4 1.8A, OTHERS PINS 0.25A
 - 2.3 DIELECTRIC WITHSTANDING VOLTAGE: 500V AC.
 - 2.4 INSULATION RESISTANCE 1000MΩ Min
 - 2.5 OPERATING TEMPERATURE: -40°C ~ 85°C
 - 3 MECHANICAL CHARACTERISTICS:
 - 3.1 MATING FORCE: 35N MAX.
 - 3.2 UNMATED FORCE: 10-35N FOR INITIAL.
 - 3.3 DURABILITY: 1,500 CYCLES
 - 4 MEASURE CPK ≥ 1.33

MOUNTING PANEL CUTOUT
(INTERNAL SIDE)

UB30F-UX11-YP153J

X	Terminal Plating
0	Au 1u" Plating
1	Au 3u" Plating
2	Au 6u" Plating
3	Au 15u" Plating
4	Au 30u" Plating
5	Au 50u" Plating

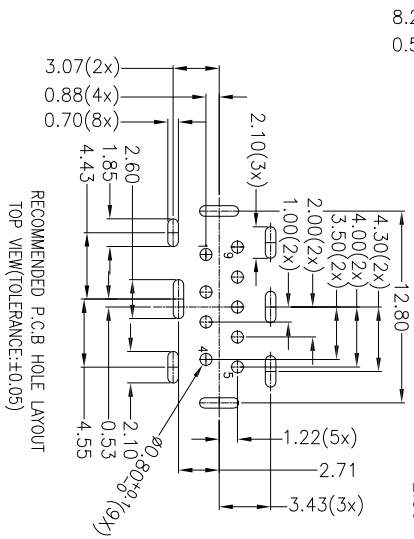
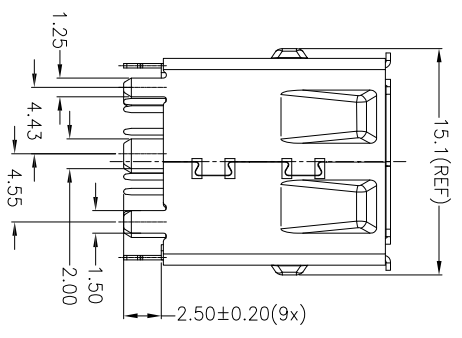
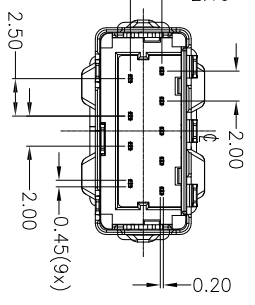
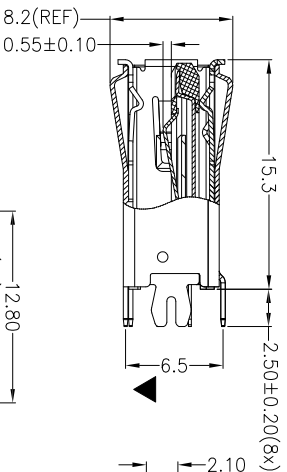
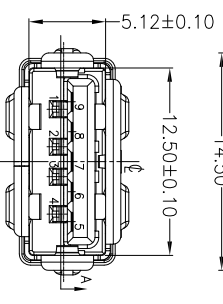
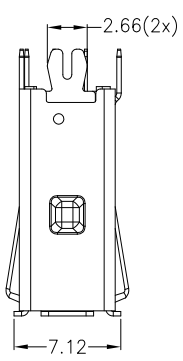

RECOMMENDED P.C.B HOLE LAYOUT
TOP VIEW(TOLERANCE±0.05)

06	BACK COVER	LCP	1	BLUE UL94 V-0 HF
05	OUT SHELL	G2680	1	T=0.3 N150u" Min
04	SHELL	SUS304	1	T=0.3 N150u" Min
03	4PIN CONTACT	G5191	1	T=0.20 Plating Ni50u" Min, Au Plating, Matte Sn100u" Min
02	SPIN CONTACT	G2680	1	T=0.20 Plating Ni50u" Min, Au Plating, Matte Sn100u" Min
01	HOUSING	LCP	1	BLUE UL94 V-0 HF
NO.	VARIETY	MATERIAL	QTY	REMARK

东莞市合陵电子有限公司
Dongguan Heling Electronic Co., LTD

SCALE: 1/1 UNIT: mm DWG. NO:

SIZE: A3 PAGE: 1 OF 1 REV: A02

APPROVED BY: Tony
CHECKED BY: XSY
PREPARED BY: ZSH

CUSTOMER COPY

4	GND	5	SSRX-
3	D+	6	SSRX+
2	D-	7	GND_DRAIN
1	VBUS	8	SS1X-
Pin NO.	Signal name	9	SS1X+

Connector Pin Assignments