

CATEGORY	DESCRIPTION	P/N #
CONNECTOR	USB3.0 AF 短体SMT(直边)	UB30F-XX11-KLRG699-X

REV.	ECN NO	DESCRIPTION	REVISED	DATE
A01	—	New Release	Jsa	2019-10-18

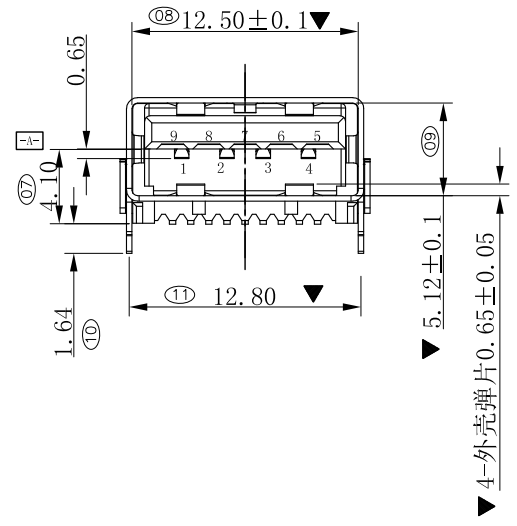
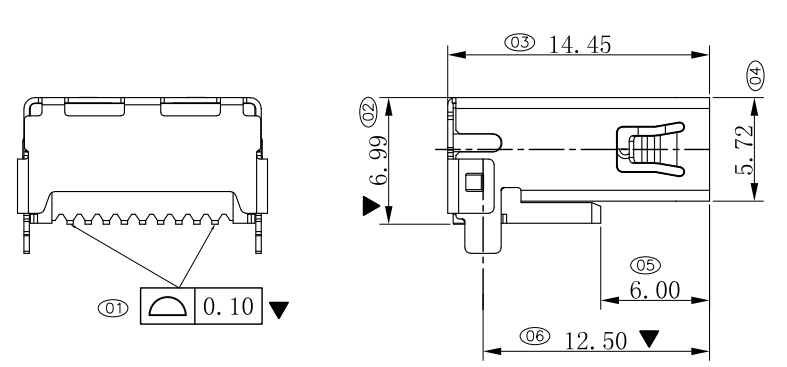

NOTE:

- MATERIAL:
 - INSULATOR:LCP UL 94V-0
 - CONTACT:BRONZE (T=0.20mm)
 - SHELL:BRASS (T=0.30mm)
- ELECTRICAL CHARACTERISTICS:
 - CONTACT RESISTANCE:30mΩ MAXIMUM
 - CONTACT CURRENT RATING:1.5A
 - DIELECTRIC WITHSTANDING VOLTAGE:500 V R. M. S.
 - INSULATION RESISTANCE 1000 MEGOHMS MIN
 - OPERATING TEMPERATURE:-40° C ~ 85° C
- MECHANICAL CHARACTERISTICS:
 - MATING FORCE:3.57kg MAX
 - UNMATED FORCE:0.82kg MIN
 - DURABILITY:MANDATORY:15,00 CYCLES
- PLATING
 - TERMINAL:
 - 50u" MIN NICKEL ALL OVER
 - 100u" MIN Tin ON SOLDER AREA
 - (1~30)u" Au ON CONTACT AREA
 - SHELL:50u" MIN. NICEL ALL OVER

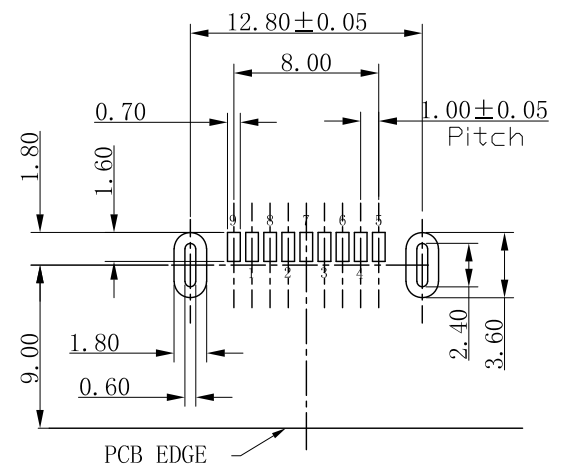
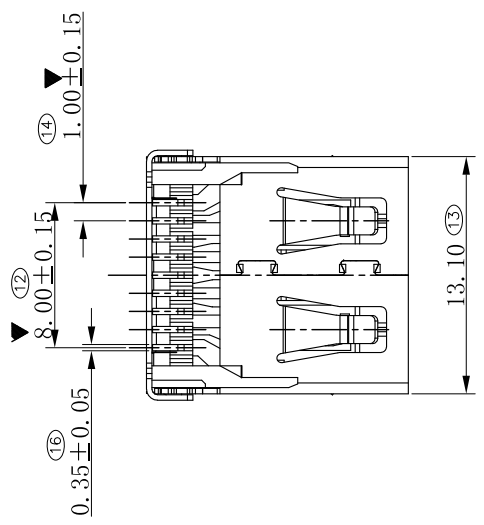

Pin NUMBER	SIGNAL NAME
1	VBUS
2	D-
3	D+
4	GND
5	StdA_SSRX-
6	StdA_SSRX+
7	GND_DRAIN
8	StdA_SSTX-
9	StdA_SSTX+
Shell	Shield

UB30F-XX11-KLRG699-X

X	Housing Color	X	包装方式
B	Black	C	载带包装
U	Blue	P	吸塑包装

X	Terminal Plating
0	Au 1u" Plating
1	Au 3u" Plating
2	Au 6u" Plating
3	Au 15u" Plating

UNLESS OTHERWISE SPECIFIED TOLERANCES

DECIMALS: X : ±0.5, X.X : ±0.3, X.XX : ±0.2

ANGLES: X : ±2°, X.X : ±1°

 东莞市合陵电子有限公司
Connector DongGuan HeLing Electronic Co.,LTD

SCALE: 1/1	UNIT: mm	DWG. NO:	
SIZE: A3	PAGE: 1 OF 1	REV: A01	
APPROVED BY	CHECKED BY	PREPARED BY	
Tony	XSY	Jsa	
CUSTOMER COPY			

CATEGORY	DESCRIPTION	P/N #
CONNECTOR	USB3.0 AF 短体SMT(直边)载带包装图	UB30F-XX11-KLRG699-C

REV.	ECN NO	DESCRIPTION	REVISED	DATE
A01	—	New Release	Jsa	2019-10-18

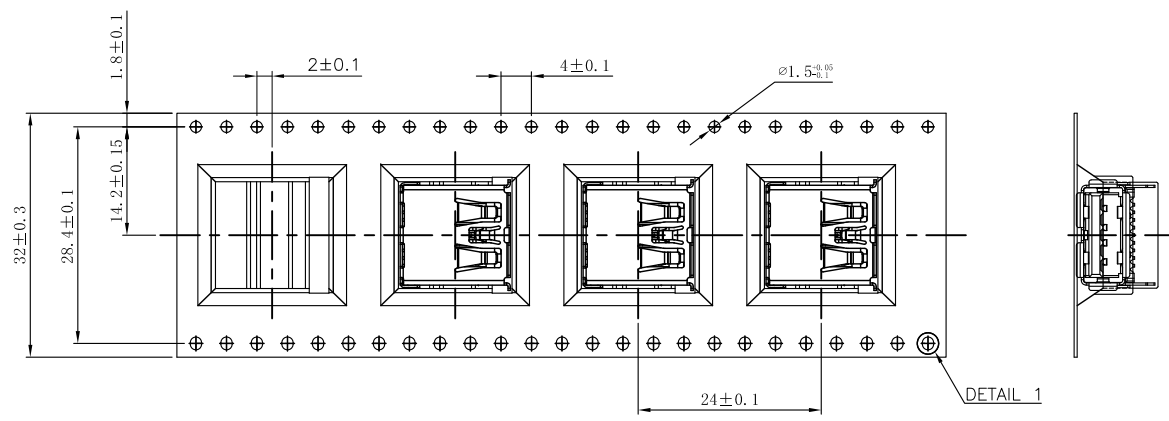

产品放置方向

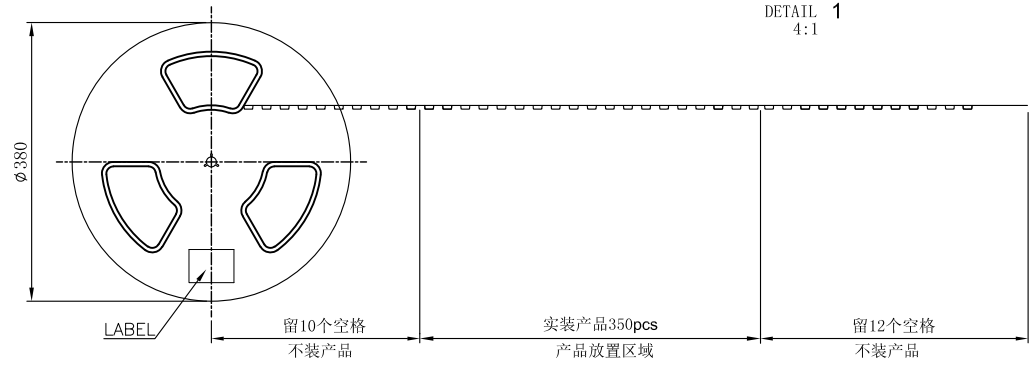
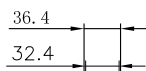

放料方向

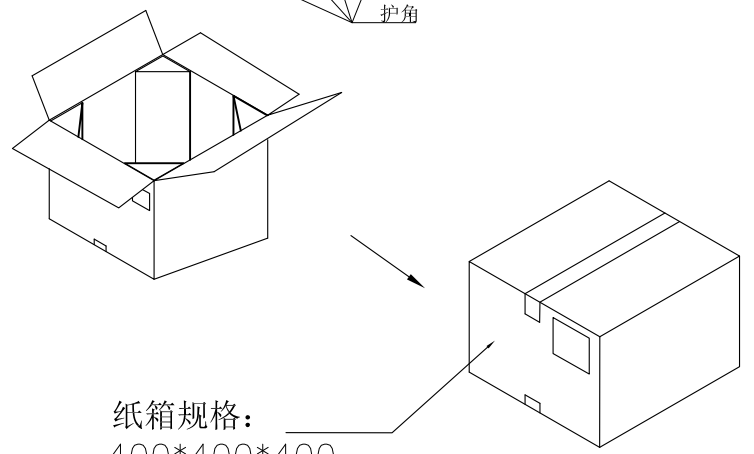
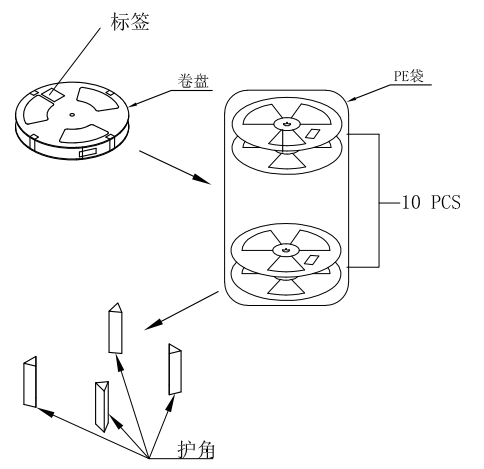

纸箱规格:
400*400*400

350	10	3500 PCS	-- KG	-- KG
PCS/ REEL	REELS/ CARTON	QUANTITY	GROSS WEIGHT	NET WEIGHT

- NOTE:
- MATERIAL:
BOX: FIBREBOARD, CORRUGATED, DOUBLE WALL.
TAPE: POLYSTYRENES, HEAT-RESISTANT TEMPERATURE: 120°C, BLACK COLOR.
REEL: POLYSTYRENES, HEAT-RESISTANT TEMPERATURE: 70°C, BLUE COLOR.
BAG: POLYETHYLENE, HEAT-RESISTANT TEMPERATURE: 100°C.
 - PEELING STRENGTH: 0.1 ~ 1.3 N (10 ~ 130 GRAMS)
 - PEELING SPEED: 300 mm/min.
 - EACH BAG SHALL BE INCLUDED DESICCANT.

 东莞市合陵电子有限公司
Connector DongGuan HeLing Electronic Co.,LTD

UNLESS OTHERWISE SPECIFIED TOLERANCES	SCALE: 1/1	UNIT: mm	DWG. NO:	
	SIZE: A3	PAGE: 1 OF 1	REV: A01	
DECIMALS: X : ±0.5 X.X : ±0.3 X.XX : ±0.2	ANGLES: X : ±2° X.X : ±1°	APPROVED BY Tony	CHECKED BY XSY	PREPARED BY Jsa
CUSTOMER COPY				