

CATEGORY	DESCRIPTION	P/N #
CONNECTOR	USB3.0 单屏蔽A母直插H15.3	UB30F-UX11-HL153J

REV.	ECONO	DESCRIPTION	REVISED	DATE
A01	—	New Release	XSY	2021.09.22

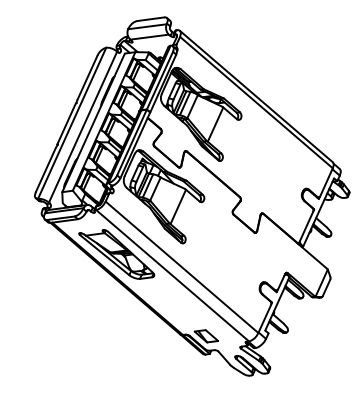
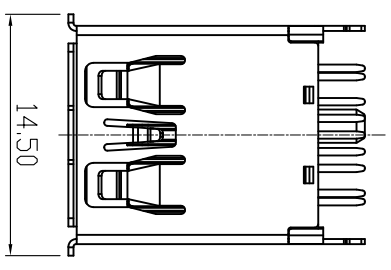

X	Terminal Plating
0	Au 1u" Plating
1	Au 3u" Plating
2	Au 6u" Plating
3	Au 15u" Plating
4	Au 30u" Plating
5	Au 50u" Plating

UB30F-UX11-HL153J

- NOTE:
- MATERIAL: SEE TABLE 1
 - ELECTRICAL CHARACTERISTICS:
 - CONTACT RESISTANCE: 30mΩ FOR CONTACT PIN1 & PIN4; 50mΩ FOR ALL OF OTHER CONTACTS, AFTER DURABILITY Δ10mΩ
 - CONTACT CURRENT RATING: PIN1&PIN4: 8A, OTHERS PINS 0.25A.
 - DIELECTRIC WITHSTANDING VOLTAGE: 500V AC.
 - INSULATION RESISTANCE: 1000MΩ Min
 - OPERATING TEMPERATURE: -40°C ~ 85°C
 - MECHANICAL CHARACTERISTICS:
 - MATING FORCE: 35N MAX.
 - UNMATED FORCE: 10-35N FOR INITIAL.
 - DURABILITY: 1,500 CYCLES

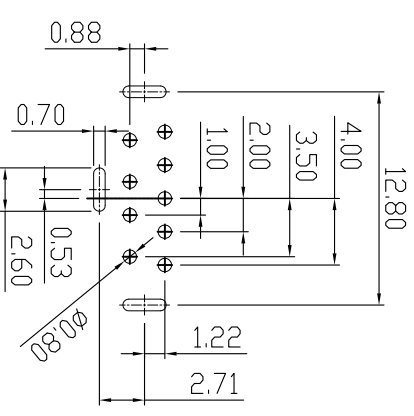
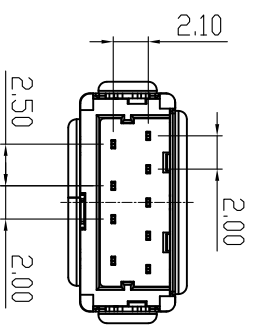
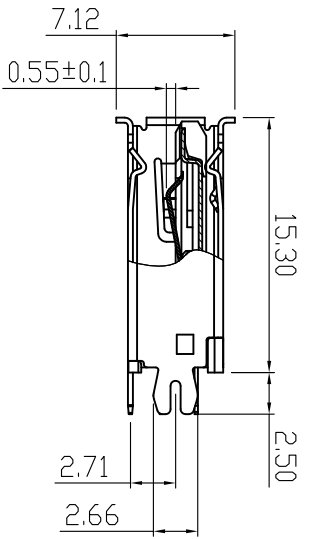
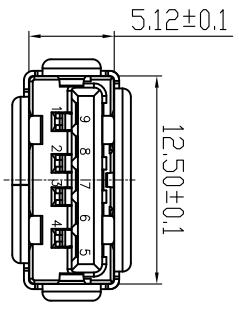

RECOMMENDED P.C.B HOLE LAYOUT
TOP VIEW(TOLERANCE:±0.05)

4	GND	5	SSRX-
3	D+	6	SSRX+
2	D-	7	GND_DRAIN
1	VBUS	8	SSTX-
Pin NO.	Signal name	9	SSTX+

Connector Pin Assignments

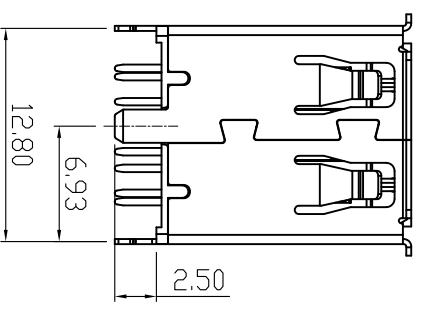

05	BACK COVER	LCP	1	BLUE UL94 V-0 HF
04	SHELL	SUS304	1	T=0.3 NISOu" Min
03	4PIN CONTACT	C5191	1	T=0.20 Plating NISOu" Min, Au Plating, Matte Sn100u" Min
02	5PIN CONTACT	C2680	1	T=0.20 Plating NISOu" Min, Au Plating, Matte Sn100u" Min
01	HOUSING	LCP	1	BLUE UL94 V-0 HF
NO.	VARIETY	MATERIAL	QTY	REMARK

UNLESS OTHERWISE SPECIFIED TOLERANCES

DECIMALS:	ANGLES:
X : ±0.5	X : ±2°
XX : ±0.3	XX : ±1°
XXX : ±0.2	

东莞市合陵电子有限公司
 Dongguan Heling Electronic Co., LTD

SCALE: 1/1	UNIT: mm	DWG. NO:
SIZE: A3	PAGE: 1 OF 1	REV: A01
APPROVED BY	CHECKED BY	PREPARED BY
Tony	XSY	ZSH
CUSTOMER COPY		