

THE REVISION STATUS OF ALL SHEETS OF THIS DRAWING IS THE SAME AS SHEET 1

LTR	DESCRIPTION	DATE	BY
-	Released	3/14/02	JCL

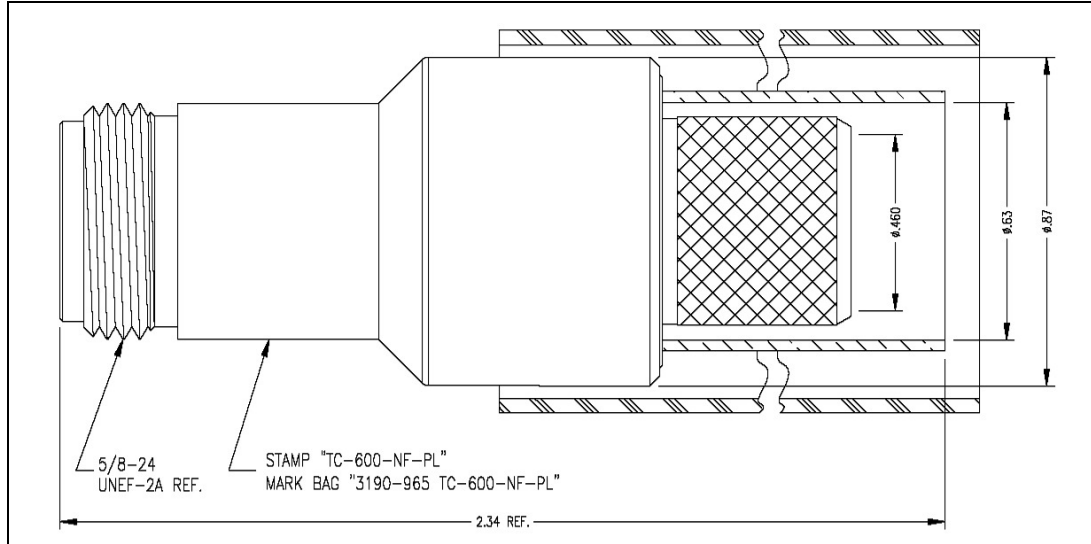

I. MATERIALS & FINISHES

- center contact: Gold Plated Brass
- outer contact: Silver Plated Brass
- body: Silver Plated Brass
- crimp sleeve: Silver Plated Copper
- dielectric: Teflon® PTFE
- shrink sleeve: Adhesive Lined Polyolefin
- crimp size: .610" hex

II. ELECTRICAL PROPERTIES

- impedance: 50 ohms
- working voltage: 1000 vrms (max)
- vswr: 1.25:1 (max) up to 6 GHz
- insertion loss: 0.1 x √Fghz

Unless otherwise specified, dimensions are in inches. Tolerances are applicable when specified.

These drawings and specifications contain proprietary information which is the property of Times Microwave Systems.

Approvals		
Drawn	JCL	3/14/02

TIMES MICROWAVE SYSTEMS
 Wallingford, CT 06492
 (203) 949-8400; (203) 949-8423.Fax
 www.timesmicrowave.com

TC-600-NF-PL
 Type-N Female (jack)
 for LMR-600-LLPLCable

Size A	CAGE CODE 68999	Drawing No.: 3190-965
Scale: NA		Rev. ()