

Skywire[®] 4G LTE CAT 4 SRC7611

Embedded Cellular Modem

Datasheet

NimbeLink Corp

Updated: June 2023



© NimbeLink Corp. 2023. All rights reserved.

NimbeLink Corp. provides this documentation in support of its products for the internal use of its current and prospective customers. The publication of this document does not create any other right or license in any party to use any content contained in or referred to in this document and any modification or redistribution of this document is not permitted.

While efforts are made to ensure accuracy, typographical and other errors may exist in this document. NimbeLink reserves the right to modify or discontinue its products and to modify this and any other product documentation at any time.

All NimbeLink products are sold subject to its published Terms and Conditions, subject to any separate terms agreed with its customers. No warranty of any type is extended by publication of this documentation, including, but not limited to, implied warranties of merchantability, fitness for a particular purpose and non-infringement.

NimbeLink is a registered trademark, and Skywire is a registered trademark, of NimbeLink Corp. All trademarks, service marks and similar designations referenced in this document are the property of their respective owners.

Table of Contents

	1
Table of Contents	2
1. Introduction	5
1.1 Scope	5
1.2 Contact Information	5
1.3 Orderable Part Numbers	5
1.4 Additional Resources	6
1.5 Product Overview	6
2. Technical Specifications	7
2.1 Block Diagram	7
2.2 Electrical Specifications	7
2.2.1 Absolute Maximum Ratings	7
2.2.2 Recommended Ratings & Module Pinout	8
2.2.2.1 Connectors J1 and J2	8
2.2.2.2 Connectors J3, X1, X2	10
2.2.3 Typical Power Consumption	10
2.2.3.1 Measurement Setup	10
2.2.3.2 NL-SW-LTE-SRC7611-4 Power Consumption	10
2.3 RF Specifications	11
2.3.1 Maximum RF Output Power	11
2.3.2 RX Sensitivity	11
2.3.3 4G LTE Uplink and Downlink Speeds	12
2.4 Mechanical Characteristics	12
2.4.1 Mechanical Drawing	12
2.4.2 Mechanical Specifications	13
2.4.3 Mating Connectors	13
2.4.4 Device Placement	13
2.4.5 Environmental Specifications	13
3. Design Considerations	14
3.1 Power Supply Design	14
3.1.1 Power Supply Requirements	14

3.2	Serial Communications	16
3.2.1	Serial UART Interface	16
3.2.2	USB Interface	17
3.3	VREF	17
3.4	nRESET	17
3.5	Power Control	18
3.5.1	ON_OFF Signal	18
3.5.2	Shutdown	19
3.5.3	Hardware Shutdown	19
3.5.4	Software Shutdown	19
3.6	Status LED	20
3.7	Dual-Image Firmware Information	20
3.8	Firmware Updates Over the Air (FOTA)	20
3.9	Soldered-Down Verizon SIM	21
3.9.1	Swapping Between SIM Interfaces During Operation	21
3.10	Cellular Antenna Requirements	22
3.10.1	Primary Antenna Requirements	22
3.10.2	Diversity Antenna Requirements	23
3.10.3	Antenna Placement	23
3.10.4	Recommended LTE Antenna	24
3.11	Skywire Reference Design	24
4.	Mounting Guidelines	25
4.1	Board-to-Board Connector Approach	25
4.1.1	Mechanical Retention	26
4.2	Solder-to-Board Connection Approach	26
5.	Regulatory Information	27
5.1	FCC & IC Compliance	27
5.2	Regulatory Certifications	27
5.3	Carrier Specific Certifications	27
5.4	Export Control Classification Number (ECCN)	28
5.5	Harmonized Tariff Code	28
5.6	Interference Statement	28
5.7	Wireless Notice	28

5.8	Modification Statement	29
5.9	End Product Labeling Requirements	29
6.	Document Version Information	30

1. Introduction

1.1 Scope

This document serves as the hardware datasheet for the NL-SW-LTE-SRC7611-4 Skywire® modem family. This document is updated often. Please be sure to download the latest version from NimbeLink's website.

1.2 Contact Information

NimbeLink's goal is to make integrating Skywire modems into end-user applications as easy as possible. Please send any feedback, documentation requests, or technical support questions to NimbeLink's product support team at:

product.support@nimbelink.com

For purchasing information, please visit the "Part Ordering Information" section on the modem's product page. Any additional sales questions or requests for quotation can be directed to NimbeLink's sales team at:

sales@nimbelink.com

1.3 Orderable Part Numbers

Orderable Device	Firmware Revision	Operating Temp	Bands	Carrier	Network Type
NL-SW-LTE-SRC7611-4	SWI9X07H_0 0.08.20.00	-40°C to +85°C	B2, B4, B5, B12, B13, B14, B25, B26, B66, B71	AT&T, Verizon	4G LTE, GNSS
NL-SW-LTE-SRC7611-4NG (EOL)	SWI9X07H_ 00.03.03.00	-40°C to +85°C	B2, B4, B5, B12, B13, B14, B25, B26, B66, B71	AT&T	4G LTE

1.4 Additional Resources

The following documents or documentation resources are referenced within this document:

[NL-SWDK Product Page](#)

[NL-SWDK User Manual](#)

[NL-SWDK2 Product Page](#)

[NL-SWDK2 User Manual](#)

1.5 Product Overview

Add robust cellular connectivity to your M2M devices with scalable radio technology with the Skywire line of modems, including RC7611-4 based LTE solutions.

Extensive experience in designing and building embedded product solutions makes the NimbeLink Skywire® embedded cellular modem the smallest on the market. It uses the popular Skywire interface and supports multiple LTE bands, minimizing costs of hardware and network access. The module is designed for volume production and is intended for OEMs to embed into end equipment designs.

NimbeLink, a global leader in embedded cellular modem technology and asset tracking solutions, has introduced the Skywire® 4G LTE CAT 4 SRC7611 modem. These Skywire modems leverage LTE Category 4 technology. The NL-SW-LTE-SRC7611-4 family is ideal for delivering fast reliable cellular connectivity to products with applications in North America.

The NL-SW-LTE-SRC7611-4 family is pin-compatible with all other Skywire form factor modems. This offers the flexibility of being able to use multiple vendors in one hardware design of your end product.

2. Technical Specifications

2.1 Block Diagram

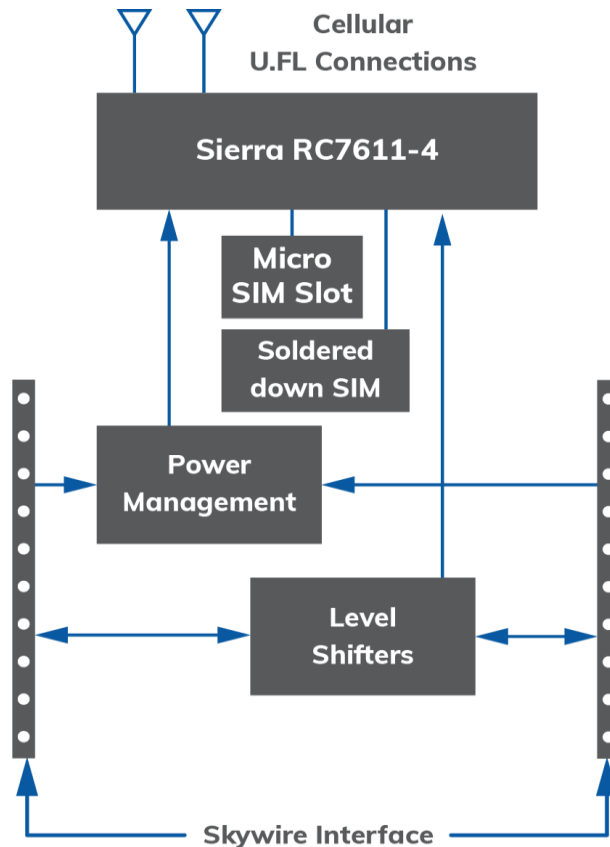

2.2 Electrical Specifications

2.2.1 Absolute Maximum Ratings

To avoid potential damage to the modem, ensure that all voltages applied to the pins listed below do not fall outside of the ranges specified by the maximum and minimum ratings:

Parameter	Signal	Minimum Rating	Maximum Rating
Main Power Supply	VCC	3.0V	5.5V
I/O Voltage Reference	VREF	1.65V	5.5V

2.2.2 Recommended Ratings & Module Pinout

2.2.2.1 Connectors J1 and J2

The following table details the pinout of the NL-SW-LTE-SRC7611-4 Skywire modem family, and recommended ratings for the Skywire interface on connectors J1 and J2. More details and design requirements for these pins are documented in [Section 2](#).

Pin	Name	Dir.	Description	Min	Typ.	Max
1 (J1-1)	VCC	Input	Main Power supply	3.0V	3.8V	5.5V
2 (J1-2)	DOUT	Output	UART data out, I/O level tied to VREF, internally pulled up to VREF.	0V		VREF
3 (J1-3)	DIN	Input	UART data in, I/O level tied to VREF	VREF Range	VIL,max	VIH,min
				1.65V to 1.95V	VREF x 0.35V	VREF x 0.65
				2.3V to 2.7V	0.7V	1.7V
				3.0V to 3.6V	0.8V	2V
				4.5V to 5.5V	VREF x 0.3V	VREF x 0.7
4 (J1-4)	GND	Input	Ground Pin		0V	
5 (J1-5)	nRESET	Input	Controls RESET input on Sierra RC7611-4, tie low for a minimum of 32ms and release to activate. Internally pulled up to 1.8V. Drive with open-drain output. Assert only in an emergency as the module will not gracefully detach from the cellular network when asserted.	VIL,min		VIL,max
				0V		0.6V
				VIH,min		VIH,max
				1.25V		1.8V
6 (J1-6)	VUSB	Input	Supply for USB interface. Will draw no more than 1mA of current.	4.75V	5V	5.25V
7 (J1-7)	USB_P	I/O	USB differential data bus (+) Requires differential impedance of 90Ω.			3.6V
8 (J1-8)	USB_N	I/O	USB differential data bus (-) Requires differential impedance of 90Ω.			3.6V
9 (J1-9)	DTR	Input	Modem Data Terminal Ready input	0V		0.63V

Pin	Name	Dir.	Description	Min	Typ.	Max
10 (J1-10)	GND	Input	Ground Pin		0V	
11 (J2-1)	GND	Input	Ground Pin		0V	
12 (J2-2)	CTS	Output	Modem Clear to Send hardware flow control output	0V		VREF
13 (J2-3)	VGPIO	Output	GPIO voltage output. See RC7611 manual for additional information.	1.7V	1.8V	1.9V
14 (J2-4)	VREF	Input	Voltage reference for off board I/O signals. This signal drives the input voltage side of an onboard buffer which converts all external I/O voltage from VREF range to 1.8V range to drive the onboard RC7611-4 module.	1.65V	1.8V or 3.3V	5.5V
15 (J2-5)	GND	Input	Ground Pin		0V	
16 (J2-6)	RTS	Input	Modem "Request to Send" hardware flow control input	VREF Range	VIL,max	VIH,min
				1.65V to 1.95V	VREF x 0.35V	VREF x 0.65
				2.3V to 2.7V	0.7V	1.7V
				3.0V to 3.6V	0.8V	2V
				4.5V to 5.5V	VREF x 0.3V	VREF x 0.7
17 (J2-7)	RFU	I/O	Reserved for Future Use (RFU). Do not connect, and leave floating on the host board.			
18 (J2-8)	RFU	I/O	Reserved for Future Use (RFU). Do not connect, and leave floating on the host board.			
19 (J2-9)	RING	Input	Modem Ring indicator pin. Open drain output, pulled up to VREF on Skywire. Pulled low when a new modem URC is available.	0V		VREF
20 (J2-10)	ON_OFF	Input	Modem On/Off signal. Assert low for at least 200 ms and then release to activate start sequence. Drive with open collector output. Internally pulled up to the internal I/O rail with a resistor. Do not use any external pull ups.	0V		0.8V

2.2.2.2 Connectors J3, X1, X2

Connector Designator	Description	Connector Location
J3	Micro SIM Connector	Bottom Side of Module
X1	Primary Antenna Connection	Top Side of Module
X2	Diversity Antenna Connection	Top Side of Module

2.2.3 Typical Power Consumption

The values contained in [Section 2.2.2.3](#) are provided as an example of typical current consumption behavior for NL-SW-LTE-SRC7611-4 Skywires.

In customer applications, current consumption may vary, and is influenced by factors such as: signal quality, ambient temperature, battery/supply voltage, supply impedance, board capacitance, and other factors.

2.2.3.1 Measurement Setup

The power data was collected using a DC energy analyzer in series with the modem's VCC pin, and an NL-SWDK with the following setup:

VCC Voltage	VREF Voltage	USB	UART
3.8V	3.3V	Not Connected	Connected to PC

2.2.3.2 NL-SW-LTE-SRC7611-4 Power Consumption

Mode	RSRP	RSRQ	Peak Current	Avg. Current	Total Charge	Notes
Socket Dial, 4G LTE	-87 dBm (No atten.)	-10 dB	271 mA	108 mA	555 µAh	Time Elapsed: 18.5 seconds Test: Power on, register, open socket, HTTP POST, read response, close socket, detach, power down
	-106 dBm (20 dB atten.)	-12.5 dB	420 mA	117 mA	607 µAh	
Idle, Registered on Network	-100 dBm	-8 dB	40.7 mA	11.5 mA	385 µAh	Time Elapsed: 120 seconds Test: 2 minute idle, modem registered, status LED disabled
Idle, Not Registered to Network	-	-	17.6 mA	10.5 mA	350 µAh	Time Elapsed: 120 seconds Test: 2 minute idle, modem not attached to LTE network (+CFUN: 4 mode), status LED disabled
Powered Off	-	-	175 µA	65.7 µA	2.19 µAh	Time Elapsed: 120 seconds Test: Modem powered off with AT!POWERDOWN, UART and USB disconnected

2.3 RF Specifications

2.3.1 Maximum RF Output Power

Available Cellular Technologies and Max TX Power	
4G LTE Technology	4G LTE CAT 4
4G LTE TX Typical Output Power	23 dBm
4G LTE TX Max Output Power	24 dBm

2.3.2 RX Sensitivity

LTE Bands		+25° (dBm)			Class A (dBm)			SIMO (Worst Case)
		Primary	Secondary	SIMO	Primary	Secondary	SIMO	
B2	Full RB BW: 10 MHz	-98	-98	-100	-97	-97.5	-99.5	-94.3
B4	Full RB BW: 10 MHz	-98	-97.5	-99.5	-97	-96.5	-98.5	-96.3
B5	Full RB BW: 10 MHz	-99	-98	-101.5	-98	-97	-99.5	-94.3
B12	Full RB BW: 10 MHz	-97	-96	-99	-96	-95.5	-98	-93.3
B13	Full RB BW: 10 MHz	-97.5	-95	-99	-96	-94	-98	-93.3
B14	Full RB BW: 10 MHz	-96.5	-97	-99.5	-96.5	-96	-98.5	-93.3
B25	Full RB BW: 10 MHz	-98	-98	-100	-97	-97.5	-99.5	-92.8
B26	Full RB BW: 10 MHz	-99	-98	-100.5	-98	-97	-99.5	-93.8
B66	Full RB BW: 10 MHz	-98	-98	-100	-97	-97	-99	-95.8
B71	Full RB BW: 10 MHz	-98	-97.5	-100	-96.5	-97	-99	-93.5

2.3.3 4G LTE Uplink and Downlink Speeds

4G LTE CAT4 Peak Uplink and Downlink Speeds	
Uplink	50 Mbps
Downlink	150 Mbps

2.4 Mechanical Characteristics

2.4.1 Mechanical Drawing

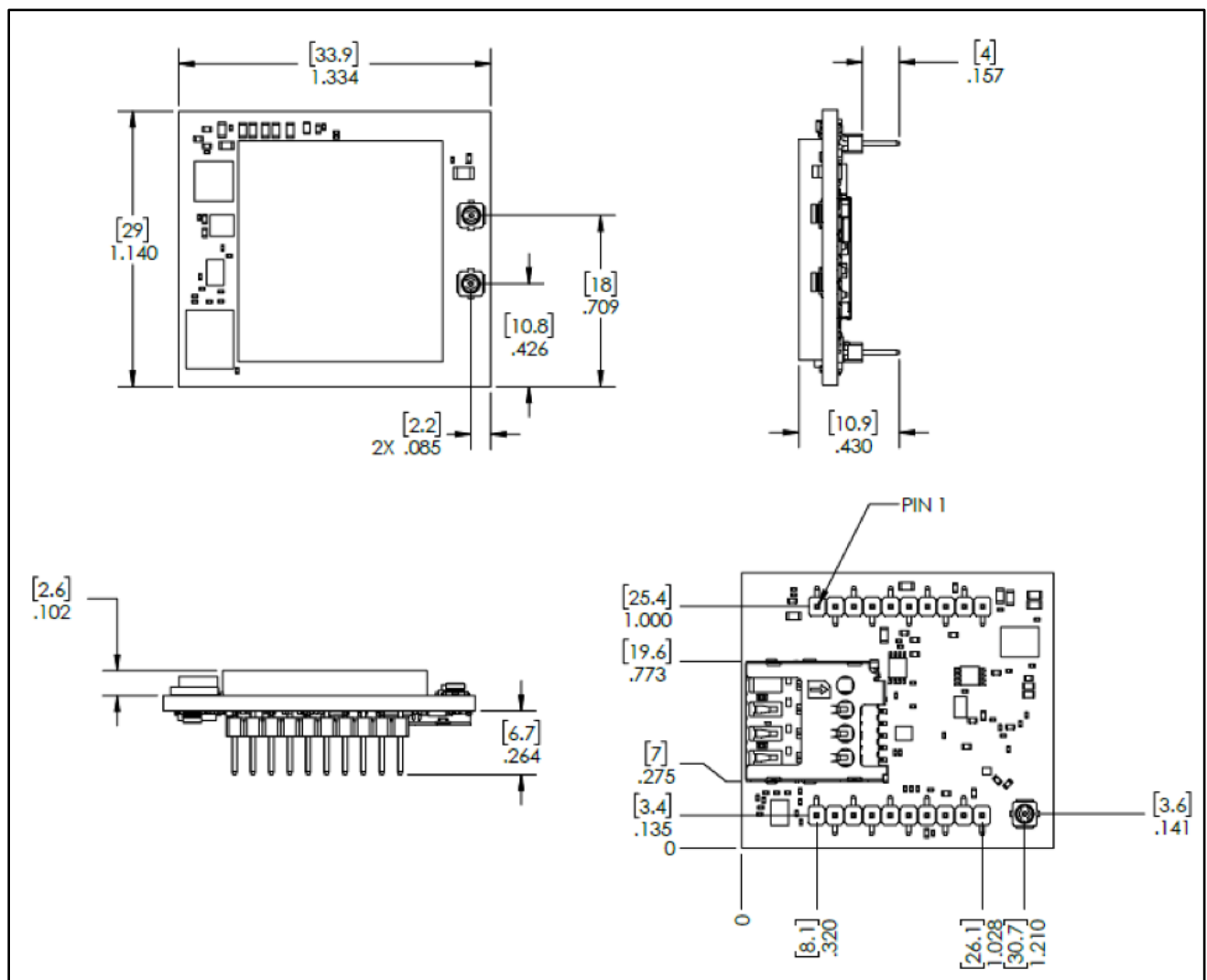

Note: Units are in inches and [mm].

2.4.2 Mechanical Specifications

Parameter	Typical	Unit
Dimensions	29.0 x 33.9 x 10.9	mm
	1.140 x 1.334 x 0.43	Inches
Weight	8	Grams
Connector Insertion/Removal	hundreds	Cycles

2.4.3 Mating Connectors

Connector Designator	Manufacturer	Populated on Module	Recommended Mate	Mate Manufacture
J1, J2	Pinrex	222-96-10GBE1	NPPN101BFCN-RC	Sullins Connector Solutions
			950510-6102-AR	3M
J3	Molex	786463001	NL-SIM-COM	Nimbelink
X1, X2	Hirose	U.FL-R-SMT(10)	CAB.011	Taoglas

2.4.4 Device Placement

⚠ Make sure the Skywire is installed in the correct orientation; failure to do so will damage the device and void the warranty.

2.4.5 Environmental Specifications

Parameter	Min	Typical	Max	Unit	Notes
Operating Temperature	-40	+25	+85	°C	
Storage Temperature	-40	+25	+85	°C	
Operating Humidity			95	%	Non-condensing

3. Design Considerations

[Section 3](#) describes important considerations that system designers should follow when utilizing a Skywire modem in a new or existing design.

NimbeLink offers schematic and layout design reviews for customers integrating Skywire modems into their designs. Contact the following email for information:

product.support@nimbelink.com

To aid with customer design efforts NimbeLink has released a Skywire Hardware Developers Guide and a Design Checklist. These supplemental documents contain design guidelines and suggestions for customers designing Skywire modems into their hardware platforms. NimbeLink strongly suggests reviewing your hardware platform against these documents to ensure proper modem integration.

[Skywire Hardware Developers Guide](#)

[Skywire Hardware Design Checklist](#)

3.1 Power Supply Design

[Section 3.1](#) contains information regarding proper power supply design for users who are designing their own baseboard for a Skywire modem. In order to ensure proper modem operation and prevent potential damage, it is crucial to follow each of the requirements listed in this section.

3.1.1 Power Supply Requirements

The NL-SW-LTE-SRC7611-4 Skywire family has a normal operating voltage range of 3.0V to 5.5V, with a recommended input voltage of 3.8V. This modem will regularly consume high amounts of current on its main power supply inputs (Pin 1, VCC) and must have a well designed power supply that can support peak transient currents up to 1.5 amps.

Parameter	Symbol	Min	Typ	Max	Unit
Operating Voltage Range	VCC	3.0	3.8	5.5	V
Current Consumption*	I _{VCC}	-	400	1500	mA

*Current consumption values depend on network configuration and are not under the modem's control. Output power, cellular band and operating voltage also affect the current consumption.

Designers must ensure that the supply voltage does not drop outside of the normal operating range at all times during modem operation. Failure to do so may cause the modem to brownout, which can cause permanent damage and void the warranty. When designing the power supply for a Skywire modem, follow these guidelines:

- Use a DC-DC switching power supply that can supply up to 1.5A of current.
 - Switching power supplies are able to rapidly respond to the sudden current demands of an LTE modem.
 - It is recommended to use a regulator with an output voltage of 3.8V.
 - To reduce EMI from the switching regulator, follow the manufacturer design guidelines closely.
- Place a minimum of a 0.1 μ F low ESR ceramic capacitor and 100 μ F low ESR ceramic capacitor close to the VCC pin of the Skywire.
 - The 0.1 μ F capacitor should be placed as close as possible to the VCC pin of the Skywire followed by the 100 μ F capacitor.
 - The capacitors should be rated to at least twice the output voltage of the switching regulator.
 - See the reference schematics below for example power supply circuits.
- Ensure that there is a low impedance power path from the baseboard power supply to the VCC pin of the Skywire.
 - Use at least an 80 mil trace width for the power supply trace to the VCC pin. However, the wider the trace, the better.
 - An increased trace width will lower the inductance of the trace, improving the ability of the power supply to meet the transient current spikes of up to 1.5A during cellular network activity.
- Use a dedicated ground plane on the baseboard.
- Power supply input cables should be kept away from noise sensitive signal lines, such as antennas or USB traces.

NimbeLink offers multiple reference designs in order to assist customers with their designs at no charge. Two of the designs are linked to below:

NL-AB-BBCL Reference Schematic:

https://nimbelink.com/Documentation/Development_Kits/NL-AB-BBCL/20057s_NL-AB-BBCL_SCH.PDF

NL-SWDK2 Reference Schematic:

https://nimbelink.com/Documentation/Development_Kits/NL-SWDK2/1002211_REVE_SCH.PDF

While prototyping with the modem, it is recommended to use a Skywire development kit, as opposed to a breadboard. Please refer to the following application note on why breadboards might cause problems and how to fix them:

Prototyping with Cellular Modems and Modules:

https://nimbelink.com/Documentation/Skywire/1001619_Breadboard_WhitePaper.pdf

3.2 Serial Communications

The NL-SW-LTE-SRC7611-4 family has two communication paths: serial (UART) and USB. The serial UART interface is targeted for applications using lower speed 8/16/32 bit microcontrollers that do not have a USB interface or easily-available USB interface drivers.

The USB interface for the modem is meant to be used by higher-end systems with a native USB interface controller or operating system, like single-board computers running Linux or Windows.

For designs that are only using the serial UART interface, NimbeLink recommends that including test points or a non-populated USB connector footprint in the design. This allows optional access to the modem's USB interface, which enables easy debugging and firmware updates.

3.2.1 Serial UART Interface

All Skywire modems support a serial UART interface with transmit and receive on pins 2 (DOUT) and 3 (DIN), respectively.

On NL-SW-LTE-SRC7611-4 family modems, the baud rate defaults to 115200 Baud 8N1. If a different baud rate is required, it can be changed with the "AT+IPR" command, as defined in the AT command manual. The syntax of the "AT+IPR" command is:

AT+IPR=<rate>

Where "<rate>" is any supported baud rate listed in the AT command manual.

The modem also supports hardware flow control (RTS/CTS) on pins 12 (CTS) and 16 (RTS). By default, the modem does have flow control enabled.

To modify the flow control setting, see the "AT+IFC" command from the AT command manual. The syntax of the "AT+IFC" command is as follows:

AT+IFC=<DTE>, <DCE>

Where "<DTE>" and "<DCE>" are replaced with either "0" to disable flow control, or "2" to enable flow control. That is, to turn on flow control, send this command:

AT+IFC=2, 2

It is recommended that any designs using the serial UART interface connect the RTS/CTS flow control lines to the host microcontroller and enable them in their application.

3.2.2 USB Interface

The NL-SW-LTE-SRC7611-4 Skywire family modems support a USB 2.0 interface on pins 6 (VUSB), 7 (USB_P), and 8 (USB_N).

Systems connecting to the modem's USB interface must observe proper design practices for connecting to a high speed USB device including, but not limited to:

- The USB D± traces should be routed as a 90 ohm impedance differential pair.
- The USB D± traces should be length matched.
- USB trace lengths should be minimized.
- USB differential pairs should be carefully routed to ensure they have a continuous return path beneath the traces. Do not route differential pairs over splits in ground or power planes.
- If the USB signals will be used off-board, ESD protection should be implemented near the off-board connector.

Pin 6 (VUSB) is the pin that the modem uses to detect if a USB host controller has been connected to the modem. This pin has an internal pulldown and must have a voltage between 4.75V and 5.25V applied to it in order to activate the USB interface. The VUSB pin will draw less than 1mA when connected.

3.3 VREF

The VREF signal (pin J2-4) drives the input voltage side of an on-board buffer which converts external I/O voltage from the VREF range to the 1.8V range in order to drive the onboard cellular module.

System designers should connect the reference voltage of their system to this pin. The VREF signal will typically draw less than 5mA when the modem is powered, however this will depend on the host system's serial interface configuration.

If the baseboard powers down the modem at any time, it should also concurrently remove the reference voltage from the VREF pin.

3.4 nRESET

In the event that the modem becomes unresponsive, pin 5 (nRESET) can be grounded to unconditionally shut down the modem. When pin 5 is grounded, the modem will cease all ongoing operations and unconditionally shut down. The modem will need the ON_OFF signal applied again to power on after a nRESET condition.

In most cases, network providers request that a device gracefully detach from the network before shutting down. Repeated use of the nRESET pin violates this request. As such, the nRESET pin should only be used as a last resort when the modem is not responding to AT commands.

Repeated failure to gracefully detach from the network during shutdown may result in the device being blacklisted from the network for a period of time, or indefinitely.

The nRESET signal is an active low signal. The signal is internally pulled up to the modem's 1.8V rail. Do not apply a voltage to this pin other than connecting it to ground.

To unconditionally shut down the modem with the nRESET signal, assert a logic-low level on nRESET using an open-drain or open-collector circuit for at least 32 ms, and then release.

If the signal is unused, it can be left floating, however, it is highly recommended that the signal be connected to the host system.

In high noise (high EMI) environments, NimbeLink recommends that designers place a 0.01 μ F - 0.1 μ F capacitor on the nRESET line near the J1 connector of the Skywire.

3.5 Power Control

3.5.1 ON_OFF Signal

The ON_OFF signal on pin 20 is used to turn the modem on, turn the modem off, and to wake the modem from deep sleep.

To conserve power, the RC7611-4 does not automatically startup when power is applied. The baseboard design must supply a means to assert the ON_OFF signal for the specified time (at least 200ms but not more than 7s) and then release to startup the module.

After asserting the ON_OFF signal, software must wait for VGPIO to assert before attempting to communicate with the RC7611-4. Holding the ON_OFF signal low for more than 7 seconds will start the modem and power down when ON_OFF is released.

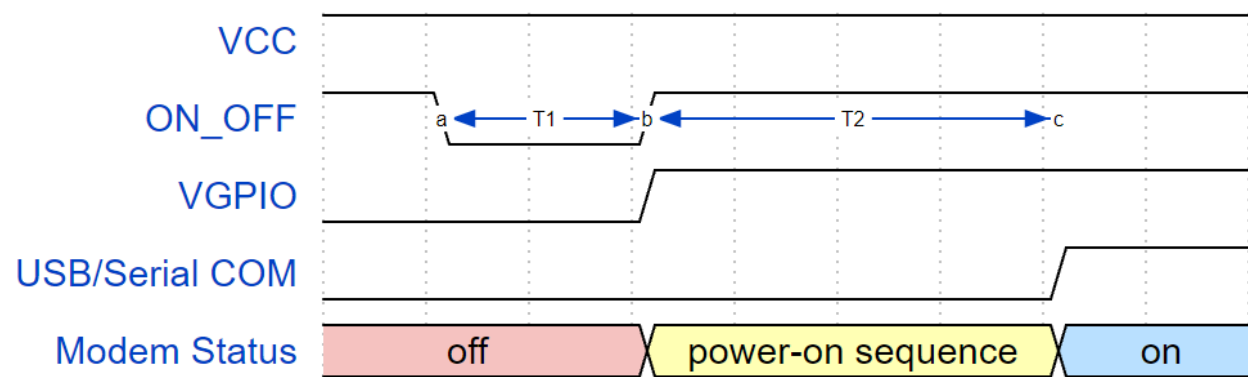

Modem	T1	T2
NL-SW-LTE-SRC7611-4 NL-SW-LTE-SRC7611-4NG	$0.2s \leq x \leq 7s$	$\sim 7s$

3.5.2 Shutdown

The modem may be properly powered off using one of the following methods:

- Hardware shutdown using the ON_OFF signal.
- Shutdown using the "AT!POWERDOWN" command.

Both of the shutdown options will force the modem to issue a detach request to the network, which informs the network that the device will be unreachable for an indefinite time. After issuing this request, the modem will power down.

For power sensitive applications it is also recommended to remove VCC and VREF from the Skywire after it has powered down. When the modem is powered down, the user must ensure that the modem is not being back-powered by any of its I/O lines.

Be sure to shut down the modem in a controlled manner, so as to allow the modem to gracefully detach from the network. Repeated failure to gracefully detach from the network during shutdown may result in the device being blacklisted from the network for a period of time, or indefinitely.

3.5.3 Hardware Shutdown

To shut down the modem using the hardware shutdown, tie the ON_OFF signal low for 2 seconds. Use the same open-collector circuitry for power-on. The user should monitor the VGPIO signal to ensure successful powering down of the modem. The power down sequence time can vary depending on the current network status of the modem.

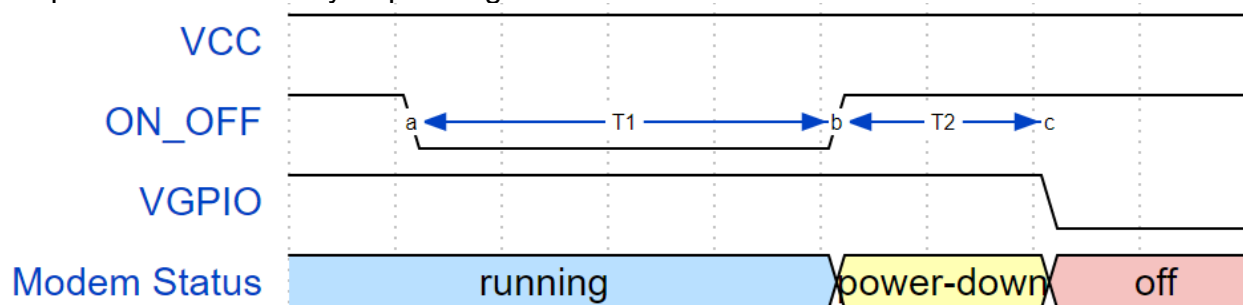

Modem	T1	T2
NL-SW-LTE-SRC7611-4 NL-SW-LTE-SRC7611-4NG	$\geq 2s$	$0.4s \leq x \leq 6s$

3.5.4 Software Shutdown

The modem can be shut down via AT command by issuing the "AT!POWERDOWN" command to modem. When shutting down the modem via AT command, the ON_OFF signal must not be grounded. The software power down sequence can take between 400ms and 5.5s.

3.6 Status LED

NL-SW-LTE-SRC7611-4 family modems feature a status LED. The LED is on when the modem has full cellular functionality enabled (**+CFUN: 1**), but is turned off otherwise.

3.7 Dual-Image Firmware Information

The NL-SW-LTE-SRC7611-4 family features Dual-image firmware. Verizon and AT&T images exist in the same firmware. The carrier image version can be changed using AT commands. Alternatively, the modem can be configured to change the firmware image based on the carrier SIM card inserted. The AT commands are shown below.

Switch carrier firmware based on inserted SIM:

AT!IMPREF="AUTO-SIM"

Switch to Verizon firmware:

AT!IMPREF="Verizon"

Switch to AT&T firmware:

AT!IMPREF="ATT"

To query current image preference:

AT!IMPREF?

Note: If **"AT!IMPREF=AUTO-SIM"** is enabled, selecting a carrier will disable it. After issuing an image preference command, it is recommended to immediately apply the settings with a reboot using **"AT!RESET"**.

3.8 Firmware Updates Over the Air (FOTA)

LTE networks are constantly being updated, improved, and enhanced with new features. Therefore, carriers tend to make frequent network changes. Most of these changes will not negatively affect network connected devices, but occasionally an update will prevent an unprepared device from re-connecting to the network permanently.

To account for these future changes, FOTA (Firmware over the Air) capability is being added to all cellular modules by manufacturers. Accordingly, NimbeLink supports this functionality in the entire Skywire family of embedded modems. However, it is often required that designers implement support for FOTA in their device's firmware.

Any Skywire developer must ensure that their device firmware can accommodate FOTA updates after deployment. Failure to do so may result in network connectivity interruptions in the event of a network change.

Should a device be rendered unable to connect to the cellular network after an update, it is impossible to resolve the issue using FOTA. In this case, the only way to fix the connectivity issue would be to physically update the device over a serial connection.

FOTA Instructions are available by contacting NimbeLink's product support team at:

product.support@nimbelink.com

3.9 Soldered-Down Verizon SIM

The NL-SW-LTE-SRC7611-4 Skywire family has the ability to select between a soldered-down Verizon SIM and a removable 3FF SIM inserted into the SIM slot, J3.

By default, the modem prioritizes the 3FF SIM card and the soldered-down SIM interface is disabled until commanded otherwise with the AT commands listed in the following sections.

3.9.1 Swapping Between SIM Interfaces During Operation

It is possible to swap between the 3FF SIM card and the soldered-down SIM at will while the modem is powered on.

To instruct the modem to use the soldered-down SIM, issue the following AT commands:

```
AT+CFUN=4
```

```
AT+WIOCFG=6,4,1,1,0,0,0
```

```
AT+CFUN=1,1
```

To instruct the modem to use the 3FF SIM Card in the SIM slot, issue the following AT commands:

```
AT+CFUN=4
```

```
AT+WIOCFG=6,4,1,0,0,0,0
```

```
AT+CFUN=1,1
```

Note: Be sure to issue "AT+CFUN=4" each time before swapping the active SIM. This will allow the modem to gracefully detach from the network before swapping its SIM.

3.10 Cellular Antenna Requirements

The NL-SW-LTE-SRC7611-4 modem family supports a primary cellular antenna connection, and a diversity antenna connection. These connectors are U.FL connectors, and are labeled as X1 and X2, respectively.

The modem's primary antenna interface, X1, supports both TX and RX communication. The diversity antenna interface is an input for a second Rx antenna to improve radio sensitivity. According to carrier requirements, both the primary and the diversity antenna must be implemented.

Note: Many antennas require the use of a U.FL to SMA cable

3.10.1 Primary Antenna Requirements

Primary Antenna Requirements			
Frequency Range	Depending on the frequency bands provided by the network operator, the customer shall use the most suitable antenna for those bands		
Bandwidth	Band	TX	RX
	B2	1850 to 1910 MHz	1930 to 1990 MHz
	B4	1710 to 1755 MHz	2110 to 2155 MHz
	B5	824 to 849 MHz	869 to 894 MHz
	B12	699 to 716 MHz	729 to 746 MHz
	B13	777 to 787 MHz	746 to 756 MHz
	B14	788 to 798 MHz	758 to 768 MHz
	B25	1850 to 1915 MHz	1930 to 1995 MHz
	B26	814 to 849 MHz	859 to 894 MHz
	B66	1710 to 1780 MHz	2110 to 2200 MHz
	B71	663 to 698 MHz	617 to 652 MHz
Impedance	50 ohm		
Input Power	≤24 dBm Average Power		
VSWR Max	2.5:1		

3.10.2 Diversity Antenna Requirements

RX Diversity Antenna Requirements			
Frequency Range	Depending on the frequency bands provided by the network operator, the customer shall use the most suitable antenna for those bands		
Bandwidth	Band	TX	RX
	B2	1850 to 1910 MHz	1930 to 1990 MHz
	B4	1710 to 1755 MHz	2110 to 2155 MHz
	B5	824 to 849 MHz	869 to 894 MHz
	B12	699 to 716 MHz	729 to 746 MHz
	B13	777 to 787 MHz	746 to 756 MHz
	B14	788 to 798 MHz	758 to 768 MHz
	B25	1850 to 1915 MHz	1930 to 1995 MHz
	B26	814 to 849 MHz	859 to 894 MHz
	B66	1710 to 1780 MHz	2110 to 2200 MHz
B71	663 to 698 MHz	617 to 652 MHz	
Impedance	50 ohm		
VSWR Max	<2.5:1		

3.10.3 Antenna Placement

The modem’s cellular antenna placement will directly affect the modem’s performance. It is vital that system designers carefully consider the placement of the antenna and follow all of the guidelines and specifications set by the antenna manufacturer. The following guidelines are general recommendations for antenna installation:

- The antenna must have an impedance of 50 ohms.
- Keep the antenna cable as short as possible.
- The antenna must not be installed inside a metal enclosure, nor near metal objects unless specified by the antenna manufacturer.
- The antenna must be installed according to the manufacturer’s instructions.

- Antenna gain must not exceed the values indicated in the regulatory requirements in [Section 5.7](#).
- Antenna integration should optimize antenna efficiency. Antennas are recommended to have >50% efficiency on all frequency bands.
- Antenna should not be mounted near noisy EM devices.

3.10.4 Recommended LTE Antenna

The following antenna is recommended by NimbeLink for use with the Skywire family of modems:

Manufacturer	Part Number	Description
Airgain	ET56AGBJA ¹	Cellular/4G/5G (617 MHz to 6000 MHz), Dipole Paddle Antenna, Rotatable On Base Hinge, SMA Connector, Black, Indoor Antenna

Note 1: U.FL to SMA adapter is required for connection to the Skywire.

3.11 Skywire Reference Design

NimbeLink offers free reference schematic and layout files as examples of how to integrate Skywire modems into various systems. Schematics, design files, gerber files, and tutorials for a variety of different systems can be found on the Skywire Development Kits webpage:

<https://nimbelink.com/development-kits/>

4. Mounting Guidelines

Skywire embedded cellular modems support two connection methods: board-to-board connectors and the solder-to-board method.

4.1 Board-to-Board Connector Approach

The Skywire interface utilizes two, 10 pin, 2mm pitch female receptacles. Many connector manufacturers can be used; below are two readily available products:

Manufacturer: Sullins Connector Solution, **Part Number:** NPPN101BFCN-RC

Manufacturer: 3M, **Part Number:** 950510-6102-AR

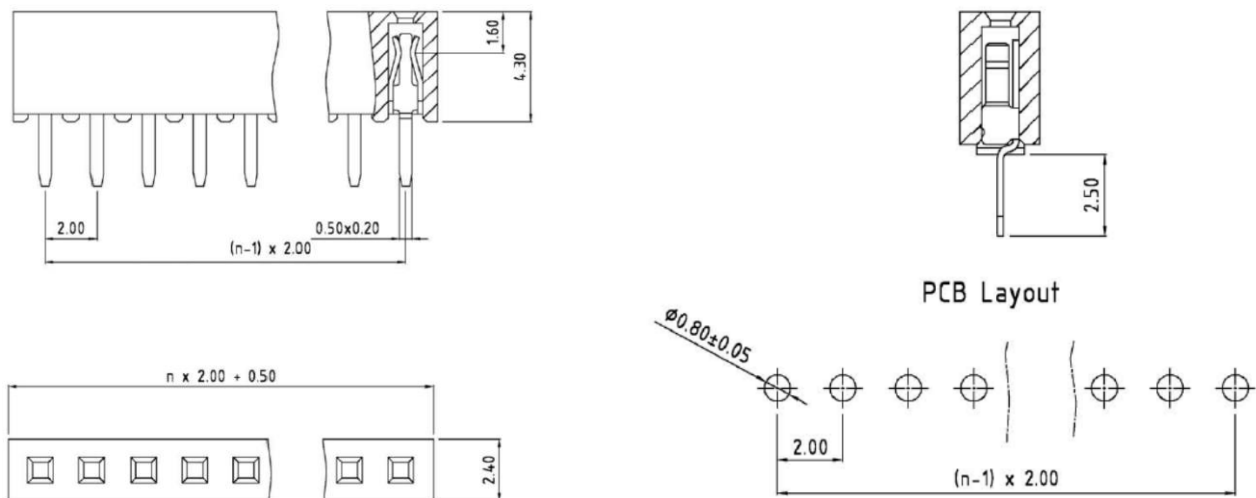

4.1.1 Mechanical Retention

Skywire modems do not have any dedicated attachment points for securing to the host board, however it can easily be secured by one of the following methods:

- Zip ties
- Foam tape mounted on the skywire to press against the enclosure
- Mechanical retention of the modem and SIM by the enclosure (example below)
 - https://nimbelink.com/Documentation/Skywire/1001460_Mechanical_Retention_Enclosure.pdf
- Solder the skywire to the host board (as described in [section 4.2](#))

4.2 Solder-to-Board Connection Approach

The second method of connection is soldering the module directly to the main board. The PCB should be designed with two rows of ten, 0.8mm plated through-holes spaced 2mm apart, with each row spaced 22mm. See below for a recommended footprint. All dimensions are in millimeters (mm):

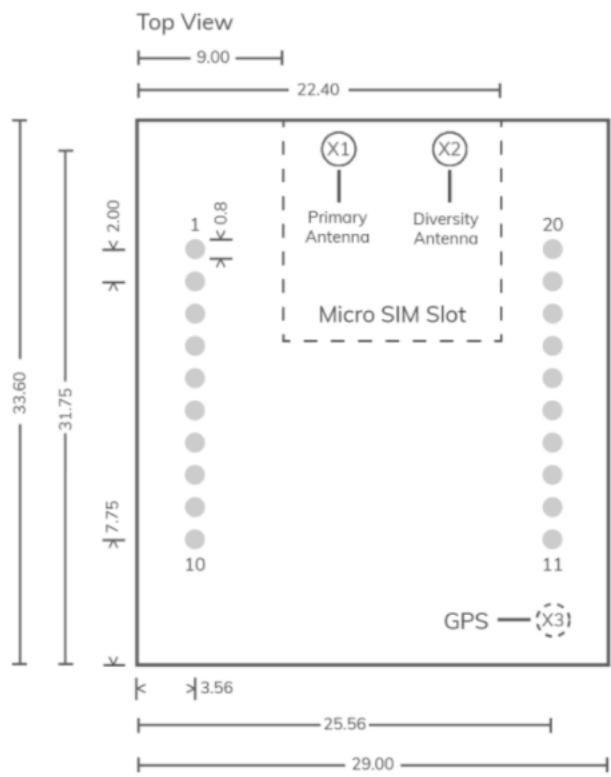

Note: U.FL locations are marked with circles. X1 and X2 are located on the top side of the board. X3 is the GPS antenna connector, but is not populated on the non-GPS "-NG" variants of the NL-SW-LTE-SRC7611-4 modem family. J3 is the micro SIM card slot on the bottom side of the board.

5. Regulatory Information

5.1 FCC & IC Compliance

If the modem's antenna is located farther than 20cm from the human body and there are no adjacent transmitters, the FCC/IC approvals of the on-board Sierra Wireless RC7611-4 cellular module can be reused by the end product.

Should the modem's antenna be mounted closer than 20cm from the human body or if there are adjacent transmitters, additional FCC/IC testing may be required for the end product.

NL-SW-LTE-SRC7611-4 family modems make use of the on-board Sierra Wireless RC7611-4 module's FCC & IC identification numbers.

Orderable Device	FCC ID	IC ID (certification number)
NL-SW-LTE-SRC7611-4 NL-SW-LTE-SRC7611-4NG	N7NRC76B	2417C-RC76B

The FCC certificate is available at the following link by searching for the FCC ID listed above: <https://www.fcc.gov/oet/ea/fccid>

The IC ID certificate is available at the following link by searching for the IC ID listed above: <https://sms-sgs.ic.gc.ca/equipmentSearch/searchRadioEquipments?execution=e1s1&lang=en>

5.2 Regulatory Certifications

- **FCC ID:** N7NRC76B
- **IC:** 2417C-RC76B
- **PTCRB:** Complete

5.3 Carrier Specific Certifications

- **AT&T:** Complete
- **Verizon:** Complete

5.4 Export Control Classification Number (ECCN)

ECCNs are five character alphanumeric designations used on the Commerce Control List (CCL) to identify dual-use items for export control purposes. An ECCN categorizes items based on the nature of the product, i.e. type of commodity, software, or technology and its respective technical parameters.

ECCN for All Skywire Modems: 5A992.c

5.5 Harmonized Tariff Code

HTS Code: 8517.62.0010

5.6 Interference Statement

This device complies with Part 15 of the FCC Rules and Industry Canada licence-exempt RSS standards. Operation is subject to the following two conditions: (1) This device may not cause harmful interference, and (2) this device must accept any interference received, including interference that may cause undesired operation.

5.7 Wireless Notice

For applications not using the recommended antennas, developers must ensure that the selected antenna(s) meet certain requirements. In order to maintain FCC and carrier specific certifications the antennas cannot exceed the maximum gain levels listed here:

Frequency Band	Max Gain (dBi)	
	Standalone	Collocated
LTE Band 2	6.00	6.00
LTE Band 4	6.00	6.00
LTE Band 5	6.00	4.00
LTE Band 12	6.00	4.00
LTE Band 13	6.00	4.00
LTE Band 14	6.00	4.00
LTE Band 25	6.00	6.00
LTE Band 26	6.00	4.00
LTE Band 66	6.00	4.00
LTE Band 71	6.00	3.00

5.8 Modification Statement

Nimbelink has not approved any changes or modifications to this device by the user. Any changes or modifications could void the user's authorization to operate the equipment.

5.9 End Product Labeling Requirements

End products utilizing NL-SW-LTE-SRC7611-4 family modems should be labeled with the following information:

Device Uses Approved Radio: NL-SW-LTE-SRC7611-4

Contains FCC ID: N7NRC76B

Contains IC: 2417C-RC76B

This device complies with Part 15 of the FCC Rules and Industry Canada licence-exempt RSS standards. Operation is subject to the following two conditions: (1) This device may not cause harmful interference, and (2) this device must accept any interference received, including interference that may cause undesired operation.

6. Document Version Information

Revision	Description	Date
1	– Initial Release	11/29/21
2	<ul style="list-style-type: none">– Updated Recommended Antennas to use Airgain antennas– Updated Revision Control– Fixed formatting errors– Updated orderable part number table to include– NL-SW-LTE-SRC7611-4	6/12/23