

DO NOT  
SCALE FROM  
THIS PRINT

TABLE 1					
ITEM	COMPONENT	-HF	-HN	-GF	-GN
1	SUB ASSEMBLY	SUB-HDBNC-J-P-HF-ST-BH1	SUB-HDBNC-J-P-HN-ST-BH1	SUB-HDBNC-J-P-GF-ST-BH1	SUB-HDBNC-J-P-GN-ST-BH1
2	NUT	HDBNC-NUT-001-N			

GENDER  
-J: JACK

TYPE  
-P: PCB

TERMINATION  
-BH: BULKHEAD THROUGH HOLE

ORIENTATION  
-ST: STRAIGHT

PLATING SPECIFICATION  
 -HF: 30µ" GOLD CENTER CONTACT,  
 3µ" GOLD OUTER CONTACT  
 -HN: 30µ" GOLD CENTER CONTACT,  
 100µ" NICKEL OUTER CONTACT  
 -GF: 10µ" GOLD CENTER CONTACT,  
 3µ" GOLD OUTER CONTACT  
 -GN: 10µ" GOLD CENTER CONTACT,  
 100µ" NICKEL OUTER CONTACT  
 (SEE TABLE 1)

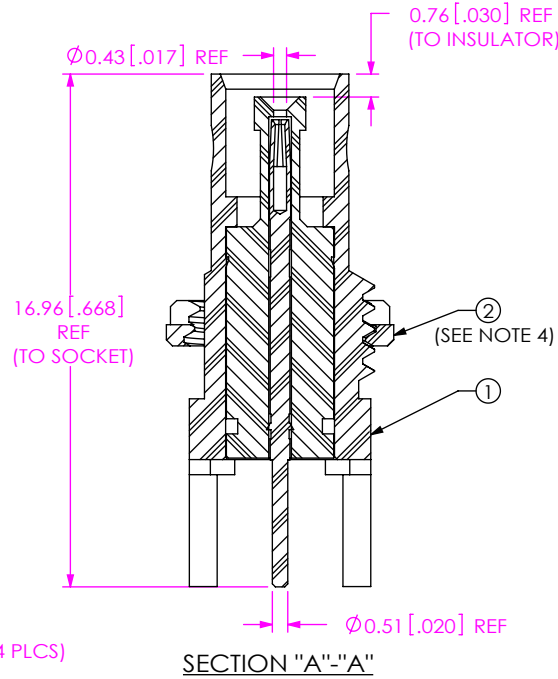
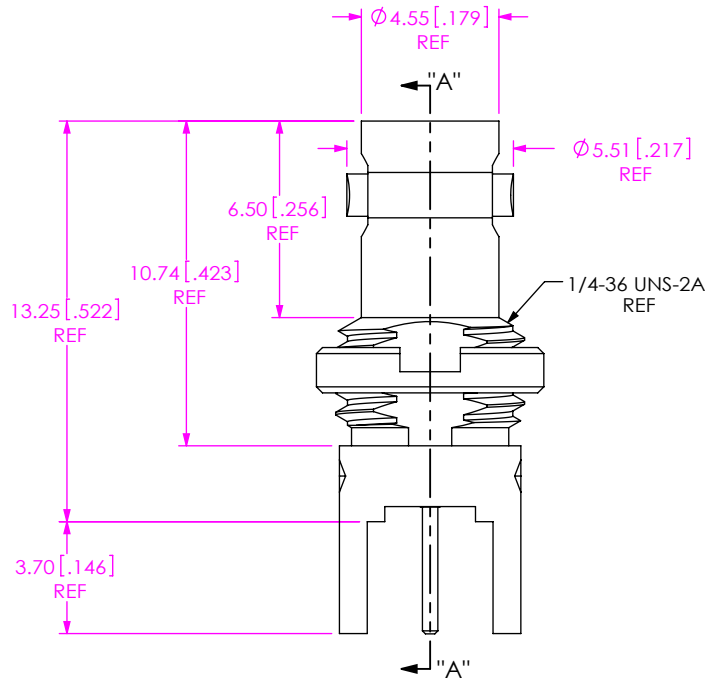
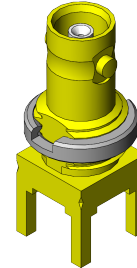
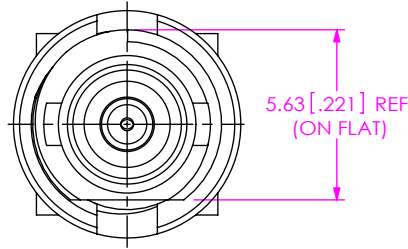

RECOMMENDED MOUNTING HOLE  
 2.20 [.079] MAX PANEL THICKNESS

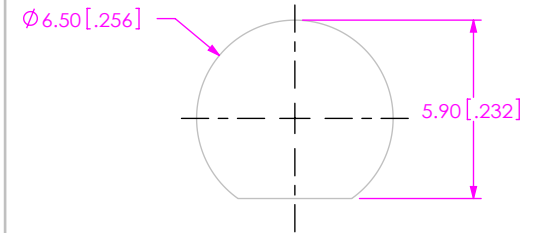

RECOMMENDED PCB LAYOUT

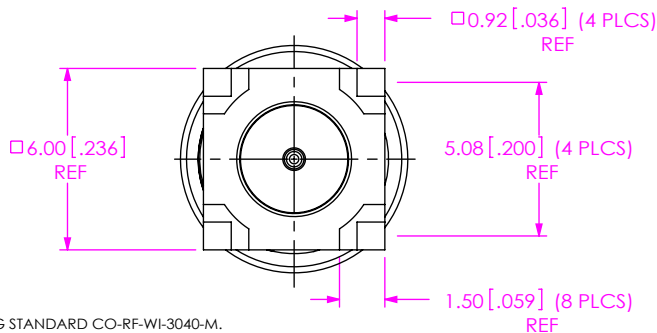
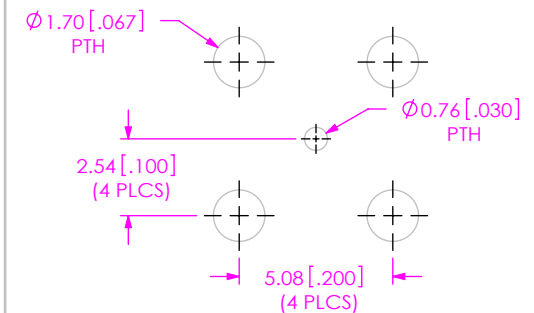

NOTES:

- ⊕ REPRESENTS A CRITICAL DIMENSION.
- NOTE DELETED.
- PRODUCT TO BE PACKAGED PER PACKING STANDARD CO-RF-WI-3040-M.  
 TRAY: TY-SMA001-1  
 COVER: TY-SMA001-2
- NUT TO BE PACKAGED SEPARATELY.

UNLESS OTHERWISE SPECIFIED,  
 DIMENSIONS ARE IN MILLIMETERS.  
 TOLERANCES ARE:  
 DECIMALS ANGLES  
 X.X: ±0.3 [.01] 5°  
 X.XX: ±0.13 [.005]  
 X.XXX: ±0.051 [.0020]

PROPRIETARY NOTE

THIS DOCUMENT CONTAINS INFORMATION  
 CONFIDENTIAL AND PROPRIETARY TO  
 SAMTEC, INC. AND SHALL NOT BE REPRODUCED  
 OR TRANSFERRED TO OTHER DOCUMENTS OR  
 DISCLOSED TO OTHERS OR USED FOR ANY  
 PURPOSE OTHER THAN THAT WHICH IT WAS  
 OBTAINED WITHOUT THE EXPRESSED WRITTEN  
 CONSENT OF SAMTEC, INC.

MATERIAL: DO NOT SCALE DRAWING

SHEET SCALE: 4:1

SOCKET: BeCu  
 SHELL, NUT: BRASS  
 INSULATOR: PTFE



520 PARK EAST BLVD, NEW ALBANY, IN 47150  
 PHONE: 812-944-6733 FAX: 812-948-5047  
 e-Mail: info@SAMTEC.com code 55322

DESCRIPTION:  
 HD BNC 75 OHM, ST JACK BULKHEAD

DWG. NO.  
**HDBNC-J-P-XX-ST-BH1**

BY: ALVIN W 02/11/2011 SHEET 1 OF 1