

GPS L1 / L5 (IRNSS) & Glonass & BDS Patch Antenna



1 SCOPE

This specification covers the dielectric Patch antenna for L1+L5+Galileo+Glonass+Beidou.

2 PART NO. : ATPGGBL5R2580A

3 OUTLINE DRAWING AND DIMENSIONS

3.1 Appearance: No visible damage and dirt.

3.2 The products conform to the RoHS directive and national environment protection law.

3.3 Pictures and Dimensions:

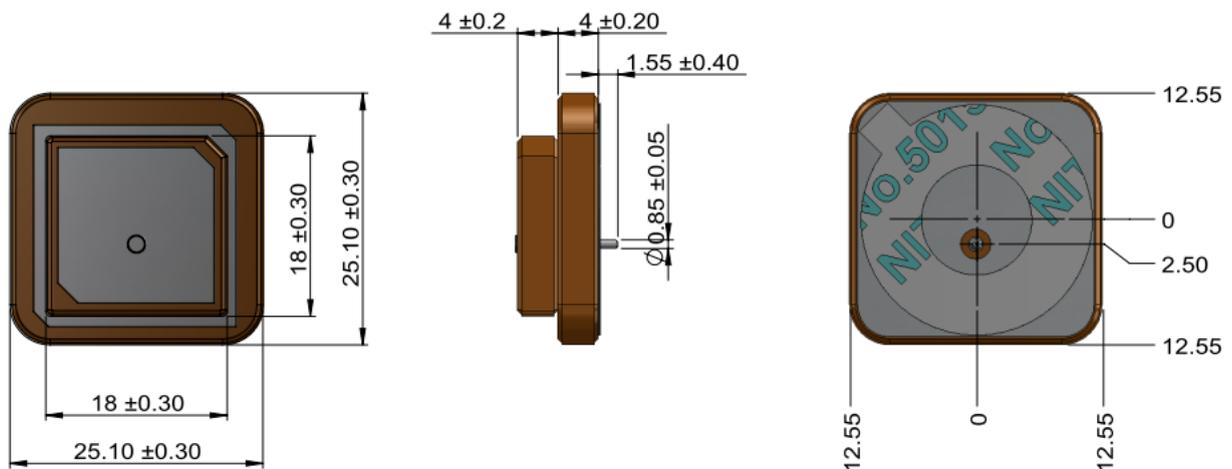

4. ELECTRICAL SPECIFICATIONS

4.1 Performance Characteristics

No	Parameter	Specification	Notes
1	Range Of Receiving Frequency	L1 : 1575.42±1.023MHz L5 : 1176.45±12MHz Galileo : 1577±14MHz Glonass : 1602±5MHz Beidou : 1561.098±2.046 MHz	
2	Center Frequency	L1 : 1572±3MHz L5 : 1174±3MHz	L1 : With 64.76×37.64 mm GND Plane L5 : With 65.36×70.88 mm GND Plane
3	Bandwidth	L1 : 22MHz min L5 : 3MHz min	Return Loss@-10dB
4	VSWR	1.8 max	Center Frequency
5	Gain at Zenith	L1 : 0.6dBi L5 : 0.5dBi Galileo : 0.6dBi Glonass : 3.4dBi Beidou : 2.4dBi	Customer Prototype
6	Axial Ratio	- - -	
7	Polarization	RHCP	Right Hand Circular Polarization
8	Impedance	50 Ohm	
9	Frequency Temperature Coefficient (τf)	-40°C to +105°C	0 ± 20ppm / °C
10	Operating Temperature	-40°C to +105°C	

※ Please follow the Golden Sample characteristics and compensation the instrument measurement value when IQC Inspection.

5. Typical Electrical Characteristics (T=25°C)

Return Loss, SWR, Impedance, measured on the test fixture

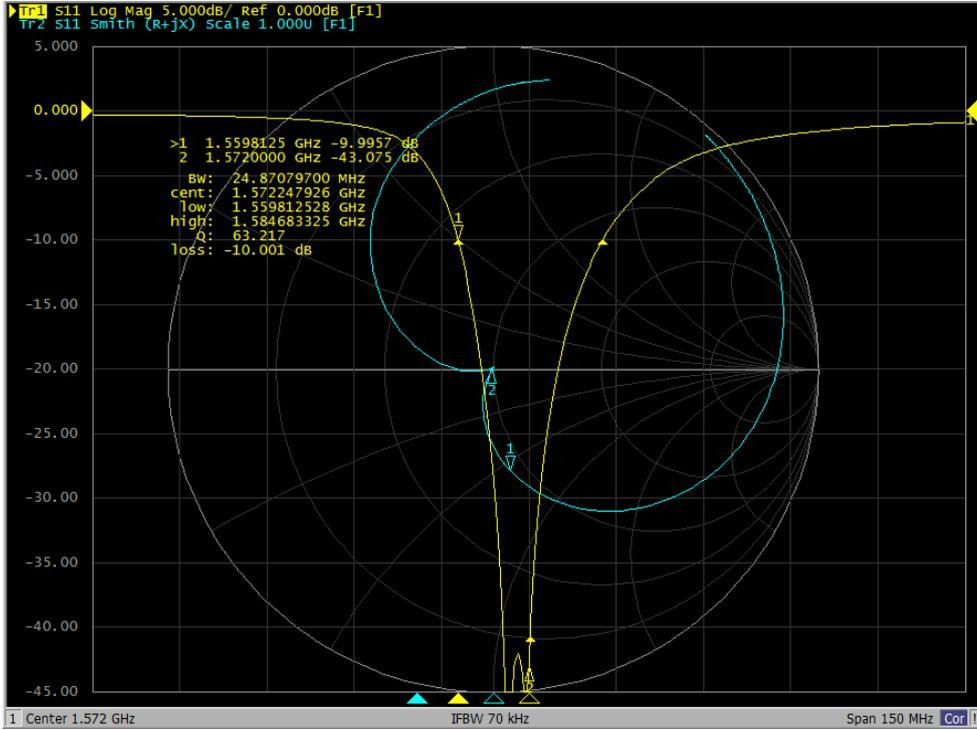

L1

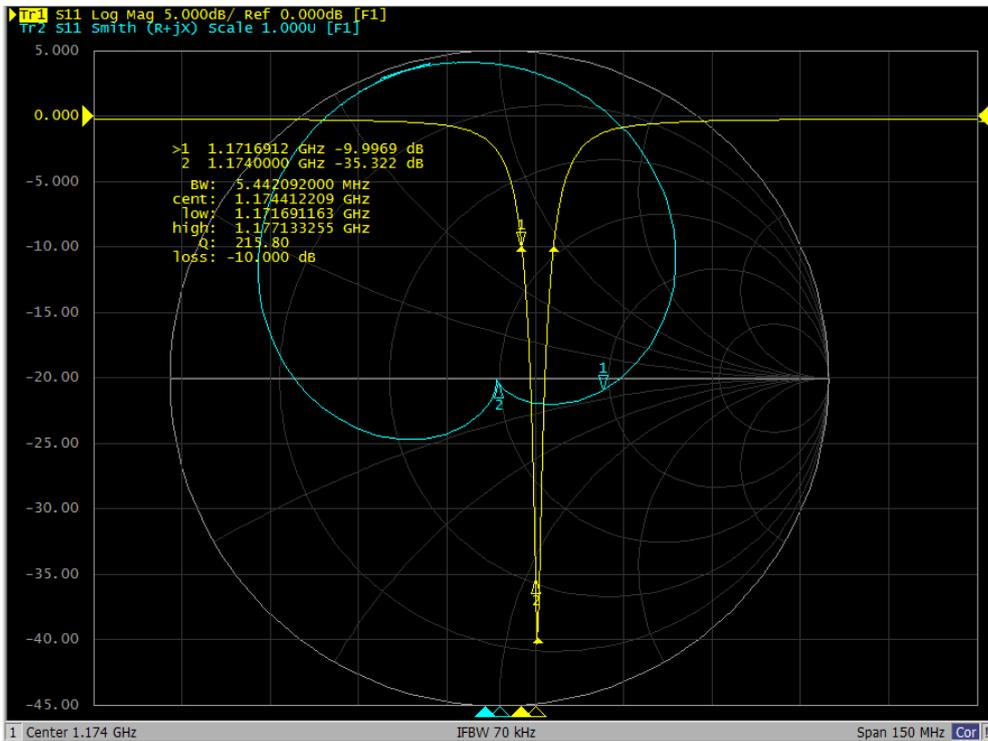

L5

Patch 25x25 ,18x18 on L1+L5+Galileo+GLONASS+BEIDOU S11 Return Loss & Smith Chart Measure.

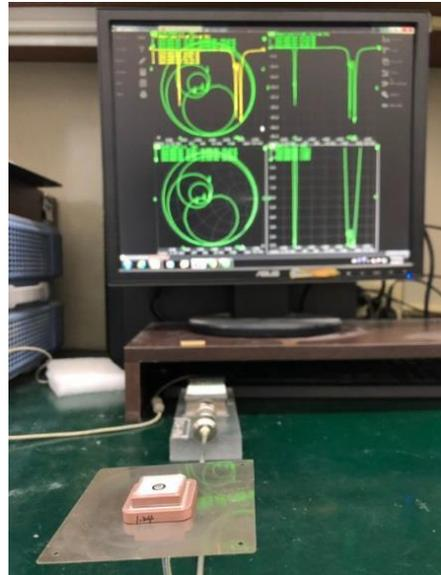
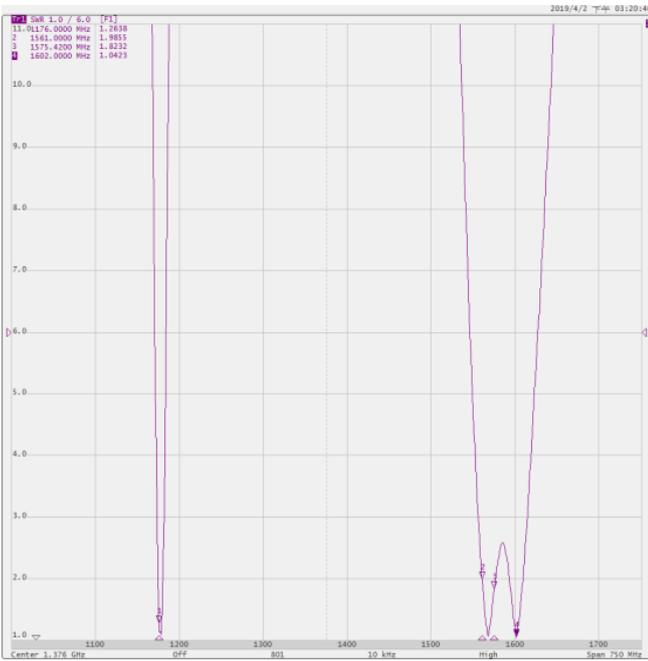
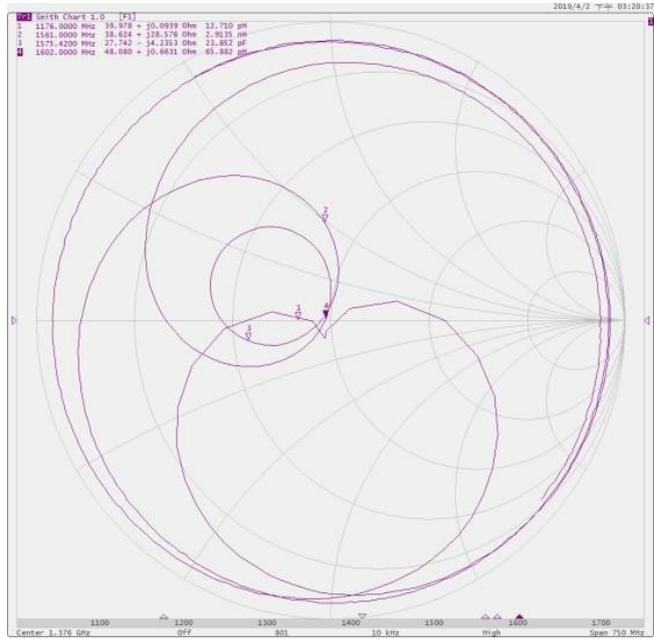
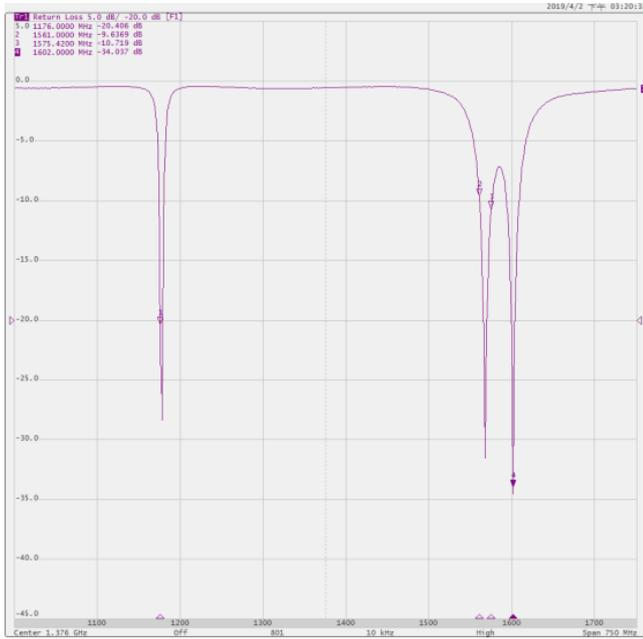

6. 2D Radiation Pattern

XZ-Plane

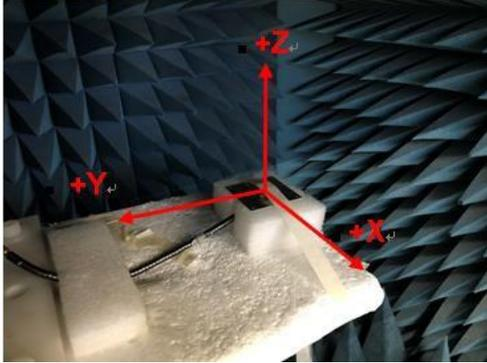

YZ-Plane

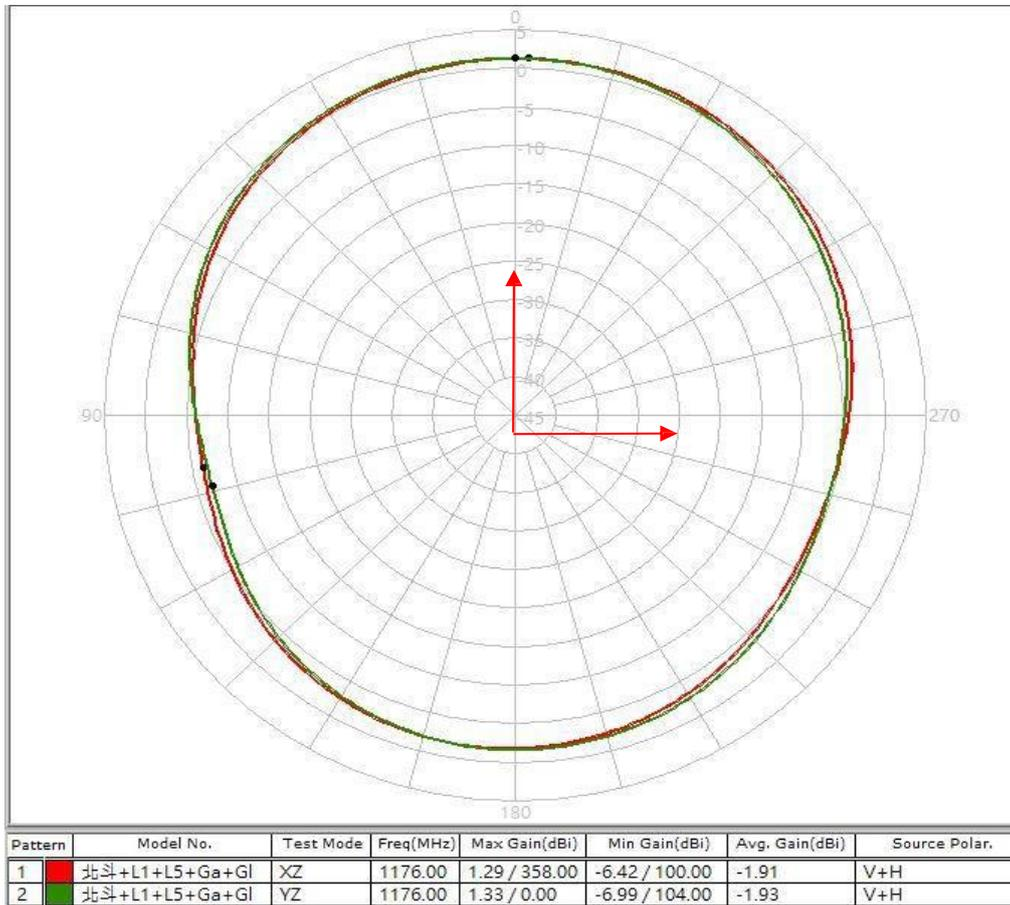
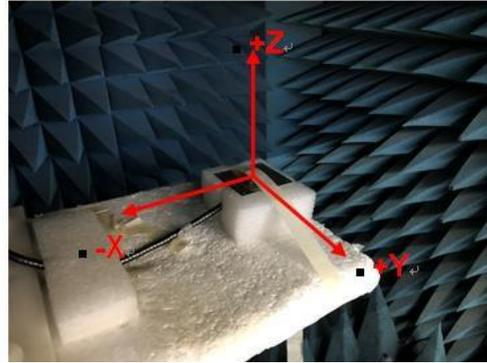

XZ+YZ -Plane 1176 MHz

1176 MHz	10° ~30°	40° ~60°	70° ~80°
XZ	-2.82	-0.16	1.17
YZ	-3.58	-0.76	1.00

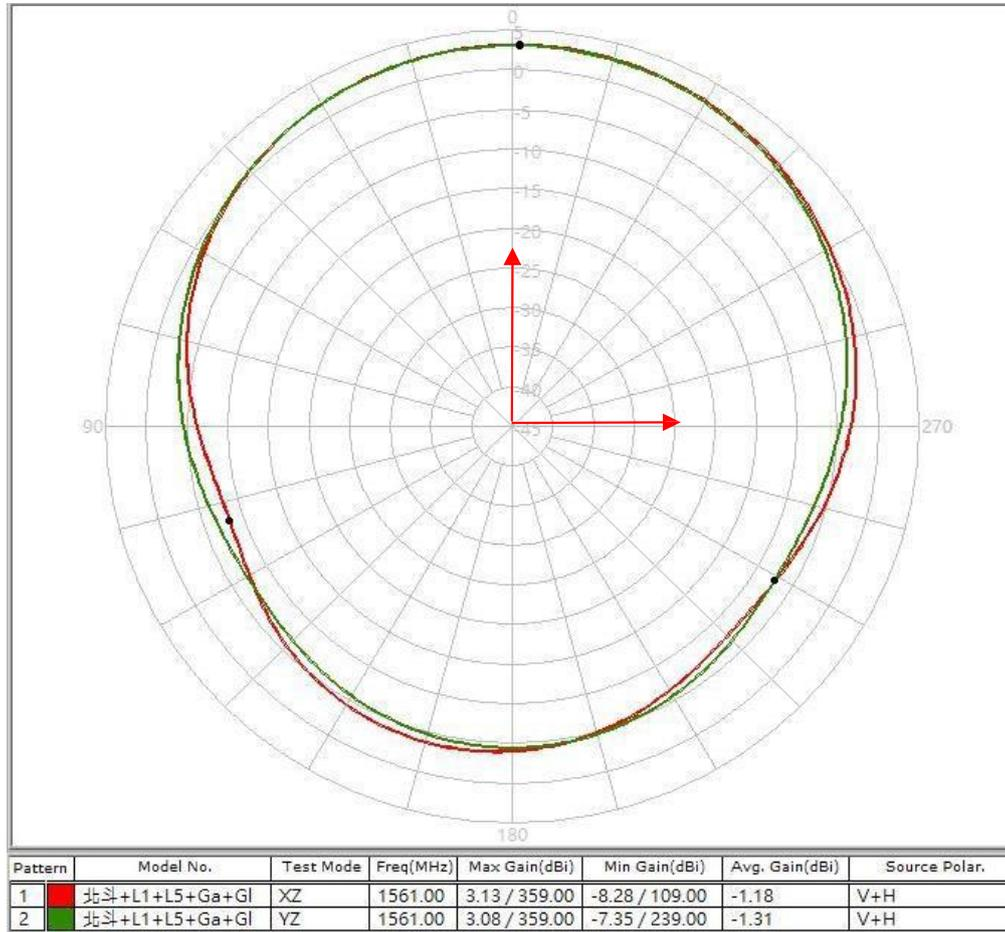

XZ+YZ -Plane 1561 MHz

1561 MHz	10° ~30°	40° ~60°	70° ~80°
XZ	-1.5	1.40	2.96
YZ	-2.37	1.05	2.85

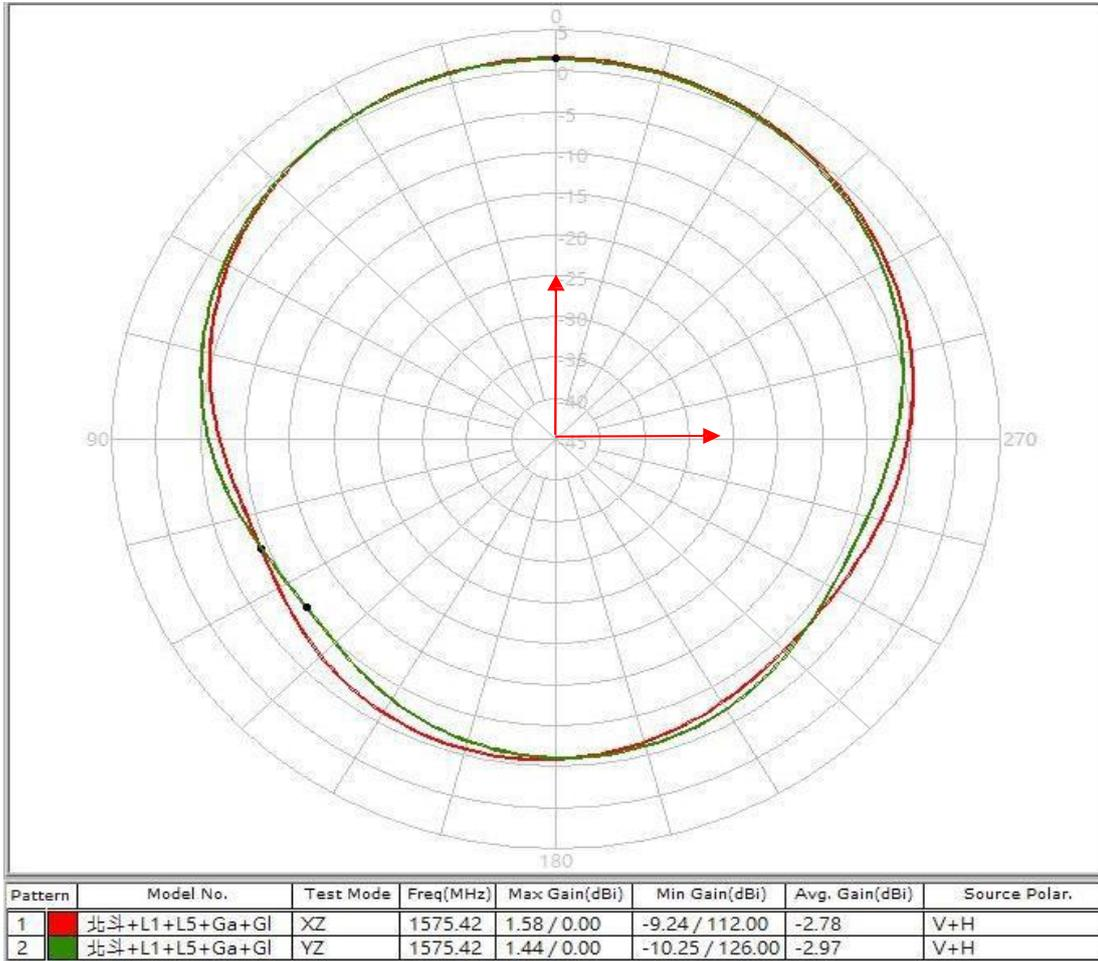

XZ+YZ -Plane 1575.42 MHz

1575.42 MHz	10° ~30°	40° ~60°	70° ~80°
XZ	-3.61	-0.57	1.29
YZ	-4.63	-0.93	1.09

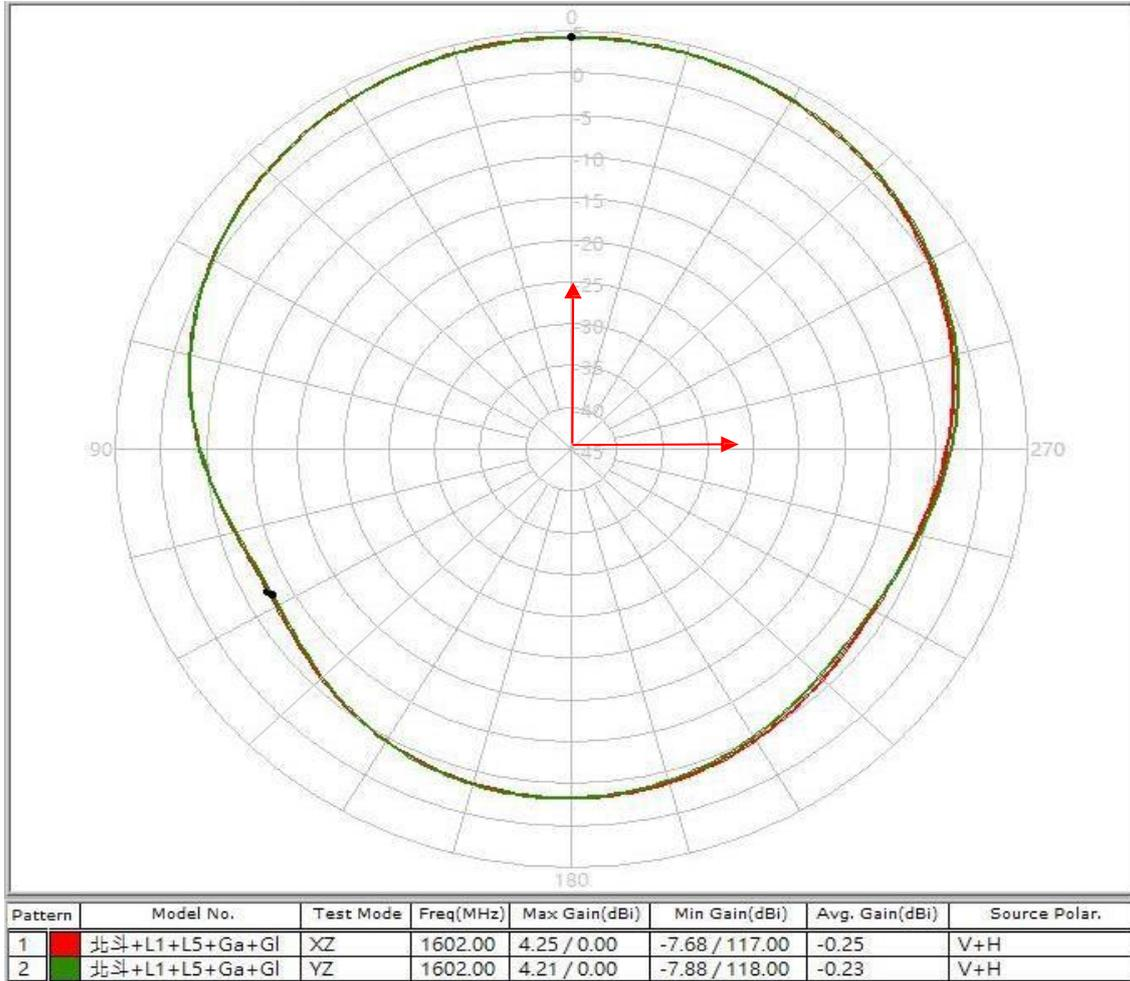

XZ+YZ -Plane 1602 MHz

1602 MHz	10° ~30°	40° ~60°	70° ~80°
XZ	-1.7	1.89	3.93
YZ	-3.58	-0.76	3.93

7. Tape Dimension

18x18

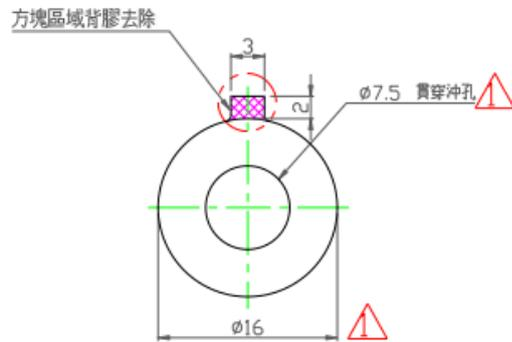

- 備註: 1.NITTO :NO.5015
2.Double-coated adhesive tape for industrial use
3.Thickness :0.12mm
4.未標示公差為 ± 0.2

25x25

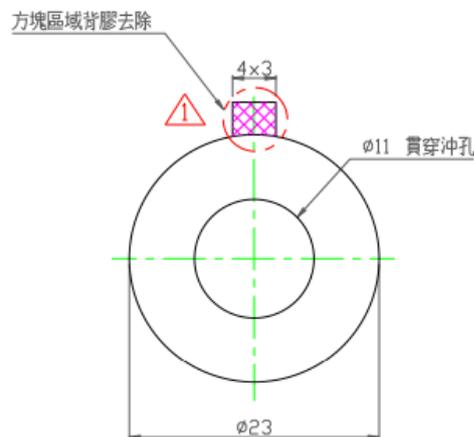

- 備註: 1.NITTO :NO.5015
2.Double-coated adhesive tape for industrial use
3.Thickness :0.12mm

8. Test Fixture for Antenna Setup & Measurements

L1 :

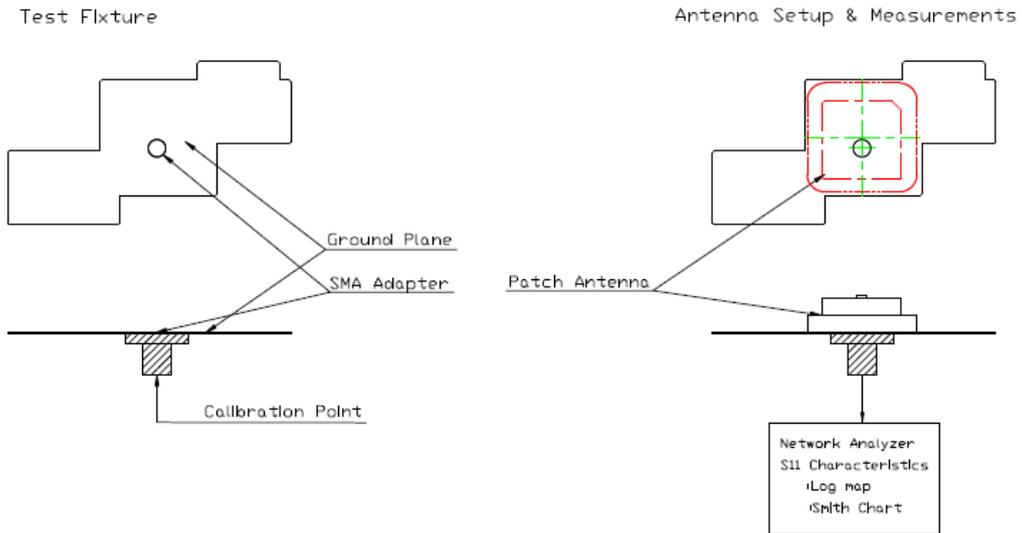

L5 :

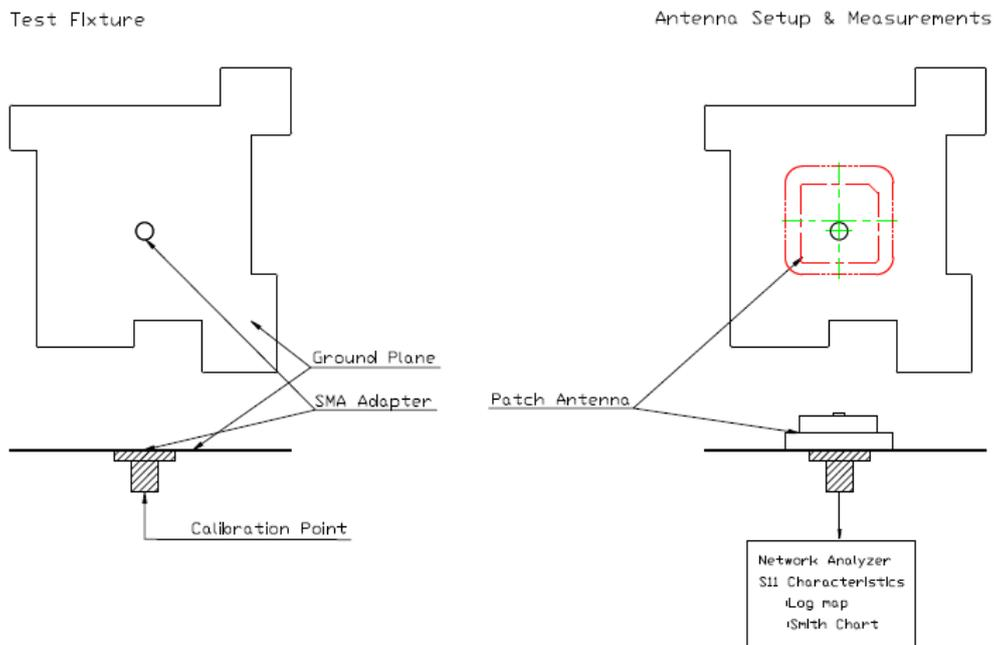

9. Characteristics and Reliability Test

Test Items		Test Condition and Procedure	Requirements
C1	S.W.R.	Set DUT on Network Analyzer; make individual calibration to test	Directive DUT specification
C2	Antenna Gain	Set DUT on Antenna Chamber; make individual calibration to test	Directive DUT specification
M1	Vibration	MIL-STD-202G, 201A Amplitude: 0.03 inch (0.76mm); Freq: 10 to 55 Hz 3 directions; 2 hours for each direction	1. No Visual Damage 2. Frequency Tol.<= 5%
M2	Random Drop	Height: 1.5 Meter; 3 directions; 1 time for each direction	1. No parts separated 2. Frequency Tol.<= 5%
M3	Solderability	MIL-STD-202G, 210F, cond. A Solder iron: 350±10°C; Duration: 5 seconds	1. Mounted on PCB 2. No Visual Damage
M4	Terminal-Pull Test	MIL-STD-202G, 211A, cond. A Holding with individual specification; force applied to axis of terminal	1. Directive DUT specification 2. Frequency Tol.<= 5%
M5	Terminal-Torque Test	MIL-STD-202G, 211A, cond. E Holding with individual specification; applied clockwise and counterclockwise to the axis of terminal	1. Directive DUT specification 2. Frequency Tol.<= 5%
M6	Dimension	Inspection of dimension, color, material, package, surface process	Directive DUT specification
E1	Salt Spray	MIL-STD-202G, 101E, cond. B Temp: 35°C; RH: >= 95%; NaCl solution: >= 5%; Time: 48 hours	After 2 Hours Recovery 1. No Visual Damage 2. Frequency Tol.<= 5%
E2	Humidity	MIL-STD-202G, 103B, cond. B Temp: 40°C; RH: >= 95%; Time: 48 hours	After 2 Hours Recovery 1. No Visual Damage 2. Frequency Tol.<= 5%
E3	Thermal Shock	1 Cycle: - 40°C (30 minutes) to + 80°C (30 minutes) Cycles: 24	After 2 Hours Recovery 1. No Visual Damage 2. Frequency Tol.<= 5%
E4	Life (High Temp.)	MIL-STD-202G, 108A, cond. A Temp: 85°C; Time: 96 hours	After 2 Hours Recovery 1. No Visual Damage 2. Frequency Tol.<= 5%
R1	RoHS	With Reference to IEC 62321:2008 with flow chart	Directive RoHS 2002/95/EC
R2	PFOS	With Reference to USA EPA 3540C:1996 by LC/MS	Directive RoHS 2006/122/EC
R3	PFOA	With Reference to USA EPA 3540C:1996 by LC/MS	Directive RoHS 2006/122/EC

10. OTHER

10.1 Caution of use

10.1.1 Please don't apply excess mechanical stress to the component and terminals at soldering.

10.1.2 The component may be damaged when an excess stress will be applied.

10.1.3 This specification mentions the quality of the component as a single unit. Please insure the component is thoroughly evaluated in your application circuit.

10.2 Notice

10.2.1 Please return one of these specifications after your signature of acceptance.

10.2.2 When something gets doubtful with this specification, we shall jointly work to get an agreement