

Low Quiescent, High Efficiency 3A Buck-Boost Converter with I²C Interface

General Description

The RT6160A is a high-efficiency, single inductor, Advanced Constant On-Time (ACOT[®]) monolithic synchronous Buck-Boost converter that can deliver up to 3A output current from 2.2V to 5.5V and well regulate to the digitally programmable output voltage from 2.025V to 5.2V, which is suitable for wide input supply range applications, regardless of input voltage is lower, higher than or even equal to the output voltage. The ACOT[®] control architecture features outstanding line/load transient response, seamless transition between buck and boost modes, provides stable operation with small ceramic output capacitors and without complicated external compensation.

The RT6160A features I²C interface, which allows programmable output voltage, ultra-sonic mode control, soft-start slew-rate adjusted and device status monitoring. The target output voltage can also be switched through external VSEL pin to perform dynamically-voltage-scaling (DVS), and the ramp-up slew-rate and ramp mode of DVS can also be set by setting the related registers.

The RT6160A operates in automatic PFM and typical 2 μ A low quiescent current design that maintains high efficiency during light load operation. At higher loads, the device automatically switches to a 2.2MHz fixed frequency control, which is easily smoothed-out the switching ripple voltage by small package filtering elements. And the integrated low R_{DS(ON)} power MOSFETs features excellent efficiency during heavy load conditions. In shutdown mode, the supply current is typically 0.1 μ A, excellent in reducing power consumption. PFM mode can be disabled if fixed frequency is desired. The RT6160A is available in a small WL-CSP-15B 1.4x2.3 (BSC) package.

Features

- **Automatic Seamless Mode Transition with Real Buck, Buck-Boost and Boost Operation**
- **Input Voltage Range : 2.2V to 5.5V**
- **Output Voltage Range : 2.025V to 5.2V with Digitally Programmable (25mV/steps)**
- **Default Output Voltage Setting :**
 - ▶ **V_{OUT} = 3.3V at VSEL = L**
 - ▶ **V_{OUT} = 3.45V at VSEL = H**
- **Maximum Continuous Output Current :**
 - ▶ **Up to 2.5A for V_{IN} \geq 2.5V, V_{OUT} = 3.3V**
 - ▶ **Up to 3A for V_{IN} \geq 3V, V_{OUT} = 3.3V**
 - ▶ **Up to 2A for V_{IN} \geq 3V, V_{OUT} = 5V**
- **Up to 95% Efficiency (V_{IN} = 3.8V, V_{OUT} = 3.3V, I_{LOAD} = 1A)**
- **1 μ A Non-Switching Low Quiescent Current**
- **I²C Interface (Up to 1MHz)**
- **Allows Dynamically-Voltage-Scaling Control**
- **Automatic PFM Mode and Forced PWM Mode Selection**
- **Ultra-Sonic Mode Operation**
- **OCP, UVLO, OTP, OVP, UVP Protected Function for Robustness**
- **15-Ball WL-CSP Package**

Applications

- Smartphones and Tablets
- Portable Devices
- Wearable Devices
- System Pre-Regulators
- Point-of-Load Regulators
- Wifi Module
- USB VCONN Supplies
- TWS Earbud Chargers

Simplified Application Circuit

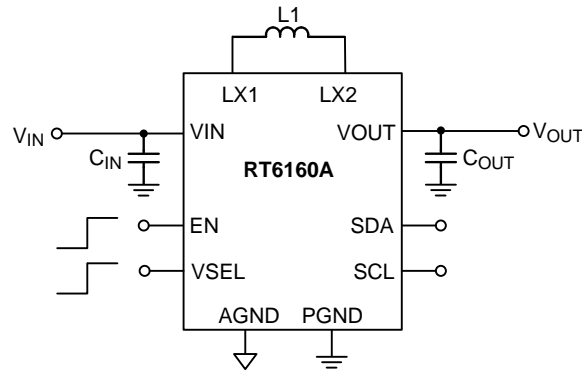

Ordering Information

RT6160A □
 Package Type
 WSC : WL-CSP-15B 1.4x2.3 (BSC)

Note:

Richtek products are Richtek Green Policy compliant and compatible with the current requirements of IPC/JEDEC J-STD-020.

Marking Information

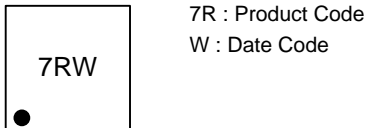

7R : Product Code
 W : Date Code

(TOP VIEW)

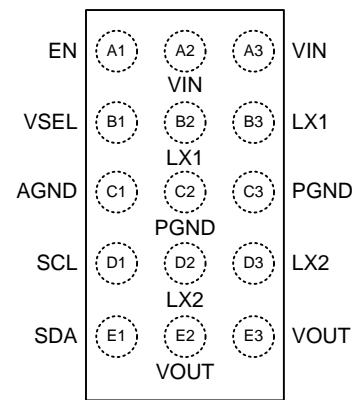

WL-CSP-15B 1.4x2.3 (BSC)

Pin Configuration

Functional Pin Description

Pin No.	Pin Name	Pin Function
A1	EN	Enable control input. A logic-high enables the converter; a logic-low forces the device into shutdown mode.
A2, A3	VIN	Power input. The input voltage range is from 2.2V to 5.5V after soft-start is finished. Connect input capacitors between this pin and PGND with minimal path. It is recommended to use a 10 μ F/6.3V/X5R/0402 and a 0.1 μ F/6.3V/X5R/0201 ceramic capacitors.
B1	VSEL	Voltage select pin. When this pin is tie to ground, V _{OUT} is set by the VOUT1 register; tie to logic-high, V _{OUT} is set by the VOUT2 register.
B2, B3	LX1	Switching node 1. Connect to the inductor.
C1	AGND	Analog ground. All signals are referenced to this pin. Avoid routing high dV/dt AC currents through this pin.
C2, C3	PGND	Power ground. The low-side MOSFET is referenced to this pin. C _{IN} and C _{OUT} should be returned with a minimal path to these pins.

Pin No.	Pin Name	Pin Function
D1	SCL	I ² C serial interface clock. This pin requires a pull-up resistor to I ² C power supply.
D2, D3	LX2	Switching node 2. Connect to the inductor.
E1	SDA	I ² C serial interface data. This pin requires a pull-up resistor to I ² C power supply.
E2, E3	VOUT	Output voltage sense through this pin. Connect to output capacitor. It is recommended to use two 22μF/10V/X5R/0603 ceramic capacitors.

Functional Block Diagram

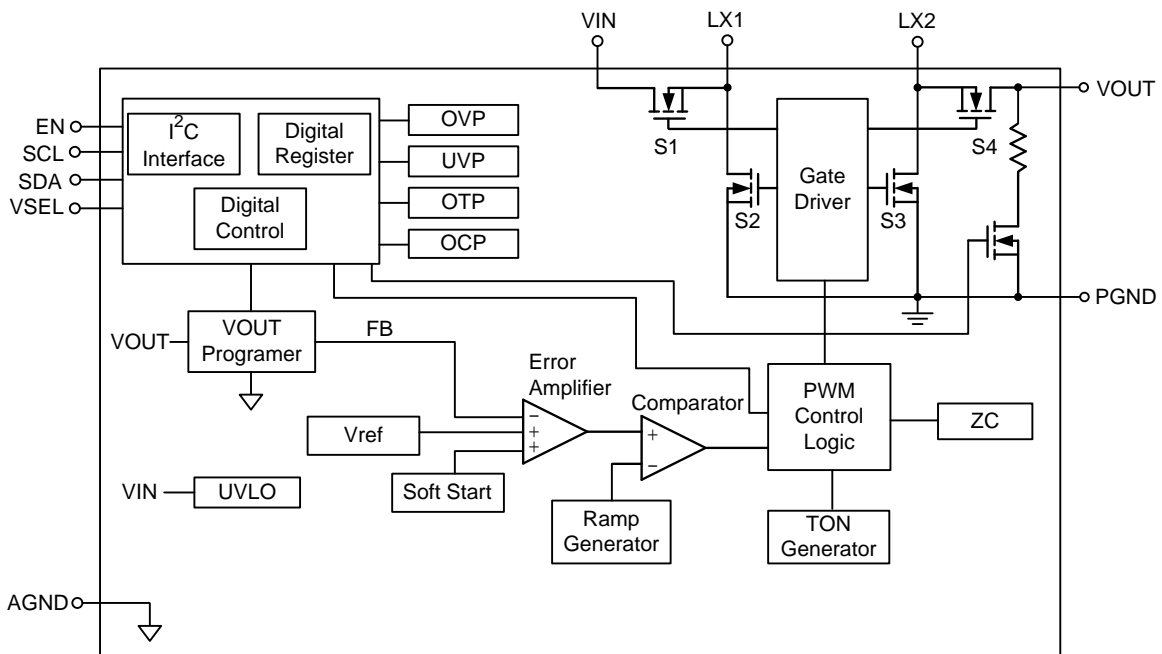

Operation

The RT6160A is a high-efficiency, single inductor, Advanced Constant On-Time ACOT[®] mode control mechanism to achieve fast-transient response and good stability with low-ESR ceramic capacitors. The ACOT[®] control scheme uses a virtual inductor current ramp generated inside the IC. This internal ramp signal replaces the ESR ramp normally provided by the output capacitor's ESR. The ramp signal and other internal compensations are optimized for low-ESR ceramic output capacitors.

Buck Operation

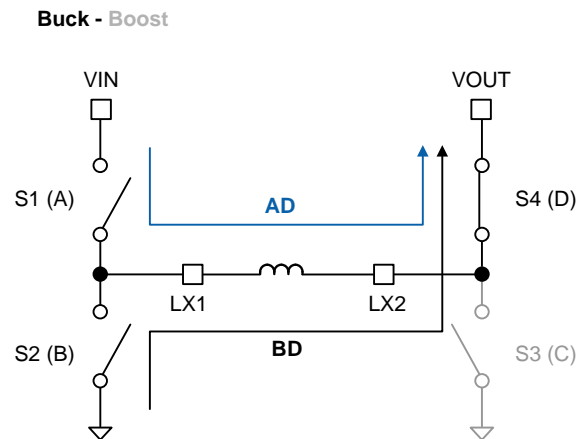

Figure 1. Buck Operation

When $V_{IN} > V_{OUT}$, the device switches like a buck converter. In steady-state buck-mode operation. The on-time one-shot turns on the high-side switch S1 (S4 keeps on) and the inductor current ramps up linearly. After the on-time, the high-side switch S1 is turned off and the synchronous rectifier switch S2 is turned on (S4 keeps on) and the inductor current ramps down linearly.

Boost Operation

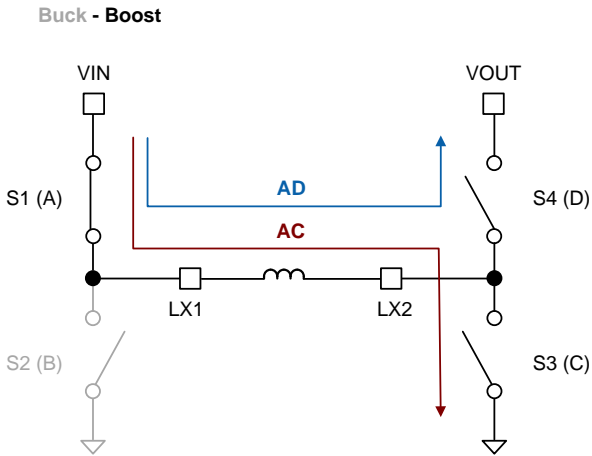

Figure 2. Boost Operation

When $V_{IN} < V_{OUT}$, the device switches like a boost converter. In boost mode at light load condition, the converter turns the S3 switch on (S1 keeps on) for a constant on-time as the one-shot is triggered, and the inductor current ramps up linearly. After the on-time, the S3 switch is turned off, and the synchronous rectifier switch S4 is turned on for a certain time (S1 keeps on) and the inductor current ramps down linearly. The S4 will turn off when inductor current drop zero. As the loading current increases and the device operates in continuous-conduction mode (CCM). When the feedback signal is less than the reference, the device turns switch S3 on (S1 keeps on) after the off-time one-shot is cleared and the inductor current ramps up linearly. Then the off-time one-shot turns S4 on (S1 keeps on) and the inductor current ramps down linearly.

Buck-Boost Operation

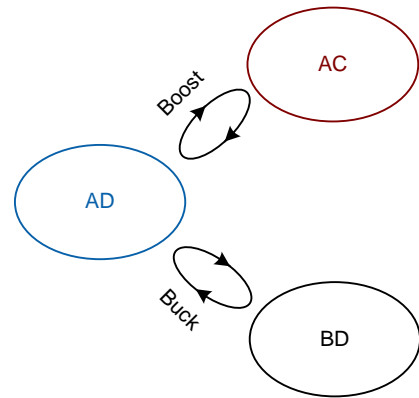

Figure 3. Buck-Boost Operation

When $V_{IN} \approx V_{OUT}$, all four transistors switch continuously, the device operates in buck-boost mode. In buck-boost mode at light-load condition, the device turns switches S1 and S3 on, and the inductor current increases linearly before reaching target peak-current level. When inductor current reaches peak-current level, the S1 and S4 are turned on for a constant time and the inductor current decreases linearly, and then the S2 and S4 switches are turned on to make sure the inductor will decrease to zero level. At light-load condition, the frequency increases as the loading increases. After the loading current is large enough, the converter will escape boundary-conduction mode and enter continuous-conduction mode. Furthermore, when V_{IN} is close to V_{OUT} in CCM, the switching frequency will decrease to half of the nominal switching frequency and the device will keep output voltage well-tracking as the target V_{OUT} .

Absolute Maximum Ratings (Note 1)

- Input Voltage, V_{IN} ----- -0.3V to 6V
- Output Voltage, V_{OUT} ----- -0.3V to 6.2V
- Switch Node Voltage, LX1, LX2 ----- -0.3V to 6V
 <50ns----- -5V to 8.5V
- Other I/O Pins Voltages (EN, VSEL, SCL, SDA) ----- -0.3V to 6V
- Power Dissipation, P_D @ $T_A = 25^\circ\text{C}$
 WL-CSP-15B 1.4x2.3 (BSC) ----- 1.88W
- Package Thermal Resistance (Note 2)
 WL-CSP-15B 1.4x2.3 (BSC), θ_{JA} ----- 53°C/W
- Junction Temperature ----- 150°C
- Lead Temperature (Soldering, 10 sec.)----- 260°C
- Storage Temperature Range ----- -65°C to 150°C
- ESD Susceptibility (Note 3)
 HBM (Human Body Model) ----- 2kV

Recommended Operating Conditions (Note 4)

- Input Voltage, V_{IN} ----- 2.2V to 5.5V
- Output Voltage, V_{OUT} ----- 2.025V to 5.2V
- Output Current, I_{OUT} ----- 0A to 3A
- Input Capacitance, C_{IN} (Note 5) ----- 5 μF (Min.)
- Output Capacitance, C_{OUT} (Note 5)----- 16 μF (Min.)
- Inductance, L----- 0.39 μH to 0.56 μH
- Ambient Temperature Range ----- -40°C to 85°C
- Junction Temperature Range ----- -40°C to 125°C

Electrical Characteristics

($V_{IN} = 3.6\text{V}$, $V_{OUT} = 3.3\text{V}$, $T_A = T_J = 25^\circ\text{C}$, unless otherwise specified)

Parameter	Symbol	Test Conditions	Min	Typ	Max	Unit
Input Operating Voltage	V_{IN}		2.2	--	5.5	V
Positive-Going UVLO Threshold Voltage	$V_{UVLO(POS)}$	V_{IN} rising	2.11	2.14	2.19	V
Negative-Going UVLO Threshold Voltage	$V_{UVLO(NEG)}$		2.02	2.05	2.08	V
UVLO Threshold Voltage Hysteresis	$V_{UVLO(HYS)}$		--	90	--	mV
Quiescent Current	I_{Q_SW}	$V_{EN} = V_{IN} = 3.6\text{V}$, $I_{OUT} = 0\text{A}$	--	2	4	μA
	I_{Q_NON-SW}	$V_{EN} = V_{IN} = 3.6\text{V}$, $I_{OUT} = 0\text{A}$, not switching	--	1	2	
Shutdown Current	I_{SHDN}	$V_{EN} = 0\text{V}$, $V_{IN} = 3.6\text{V}$	--	0.1	1	μA

Parameter	Symbol	Test Conditions	Min	Typ	Max	Unit
High-Level Input Current	I _{IH}	V _{SCL} = V _{SDA} = V _{SEL} = 1.8V, no pull-up resistor	--	--	0.1	μA
Low-Level Input Current	I _{IL}	V _{SCL} = V _{SDA} = V _{SEL} = 0V, no pull-up resistor	--	--	0.1	μA
Input Bias Current	I _{IB}	V _{EN} = 0 to 5.5V	--	--	0.1	μA
High-Side Switch Leakage Current	I _{HS_LK}	V _{EN} = 0V, V _{SW} = 0V	--	1	--	μA
High-Side Switch On-Resistance	R _{DS(ON)_H}		--	25	--	mΩ
Low-Side Switch On-Resistance	R _{DS(ON)_L}		--	38	--	mΩ
Output Discharge Resistor	R _{DIS_OUT}	V _{EN} = 0V	--	5	--	Ω
Enable Input High Threshold	V _{ENH}	V _{IN} = 2.2V to 5.5V	1.2	--	--	V
Enable Input Low Threshold	V _{ENL}	V _{IN} = 2.2V to 5.5V	--	--	0.4	V
(SCL, SDA, VSEL) Input High Threshold	V _{IH}		1.2	--	--	V
(SCL, SDA, VSEL) Input Low Threshold	V _{IL}		--	--	0.4	
Output Voltage Range	V _{OUT}		2.025	--	5.2	V
Default Output Voltage	V _{SEL_L}	V _{SEL} = low	--	3.3	--	V
	V _{SEL_H}	V _{SEL} = high	--	3.45	--	
Output Voltage Accuracy	ACC_Forced	Forced PWM operation	-1	--	1	%
	ACC_AUTO	Auto PFM operation	-1	--	3	
	ACC_USC	Ultra-Sonic operation	-1	--	3	
Line Regulation	V _{OUT_LINE_REG}	(Note 6)	--	0.5	--	%
Load Regulation	V _{OUT_LOAD_REG}	(Note 6)	--	0.5	--	%
Maximum Continuous Output Current	I _{OUT_MAX}	V _{IN} ≥ 2.5V, V _{OUT} = 3.3V, L = 0.47μH, C _{IN} = 10μF, C _{OUT} = 44μF (Note 7)	2.5	--	--	A
		V _{IN} ≥ 3V, V _{OUT} = 3.3V, L = 0.47μH, C _{IN} = 10μF, C _{OUT} = 44μF (Note 7)	3	--	--	
High-Side MOSFET Peak Current Limit	I _{LIM_P}	V _{IN} = 3.6V, V _{OUT} = 3.3V	4.5	5	5.5	A
Low-Side MOSFET Valley Current Limit	I _{LIM_V}	V _{IN} = 3.6V, V _{OUT} = 3.3V	4	4.5	5	A
PFM to PWM Threshold Inductor Current	I _{L_T_PFM}	V _{IN} = 3.6V, V _{OUT} = 3.3V, L = 0.47μH, C _{IN} = 10μF, C _{OUT} = 44μF	--	0.3	--	A

Parameter	Symbol	Test Conditions	Min	Typ	Max	Unit
Efficiency	Eff	V _{IN} = 3.3V, V _{OUT} = 3.3V, I _{OUT} = 0.1A, L = 0.47μH, C _{IN} = 10μF, C _{OUT} = 44μF, Auto PFM operation	--	95	--	%
		V _{IN} = 3.3V, V _{OUT} = 3.3V, I _{OUT} = 1A, L = 0.47μH, C _{IN} = 10μF, C _{OUT} = 44μF, Forced PWM operation	--	94	--	
		V _{IN} = 3.8V, V _{OUT} = 3.3V, I _{OUT} = 0.1A, L = 0.47μH, C _{IN} = 10μF, C _{OUT} = 44μF, Auto PFM operation	--	94	--	
		V _{IN} = 3.8V, V _{OUT} = 3.3V, I _{OUT} = 1A, L = 0.47μH, C _{IN} = 10μF, C _{OUT} = 44μF, Forced PWM operation	--	95	--	
Output Ripple Voltage	V _{OUT_RIPPLE}	V _{IN} = 3.3V, V _{OUT} = 3.3V, I _{OUT} = 0.1A, L = 0.47μH, C _{IN} = 10μF, C _{OUT} = 44μF, Auto PFM operation (Note 6)	--	50	--	mV
		V _{IN} = 3.3V, V _{OUT} = 3.3V, I _{OUT} = 1A, L = 0.47μH, C _{IN} = 10μF, C _{OUT} = 44μF, Forced PWM operation (Note 6)	--	20	--	
		V _{IN} = 3.8V, V _{OUT} = 3.3V, I _{OUT} = 0.1A, L = 0.47μH, C _{IN} = 10μF, C _{OUT} = 44μF, Auto PFM operation (Note 6)	--	25	--	
		V _{IN} = 3.8V, V _{OUT} = 3.3V, I _{OUT} = 1A, L = 0.47μH, C _{IN} = 10μF, C _{OUT} = 44μF, Forced PWM operation (Note 6)	--	10	--	
Load Transient Response	V _{OUT_LOAD_TRANSIENT}	V _{IN} = 3.8V, V _{OUT} = 3.3V, I _{OUT} = 0.05A to 1A, t _R = t _F = 1μs (Note 6)	-100	--	100	mV
		V _{IN} = 3.8V, V _{OUT} = 3.3V, I _{OUT} = 0.05A to 0.5A, t _R = t _F = 1μs (Note 6)	-50	--	50	
Line Transient Response	V _{OUT_LINE_TRANSIENT}	I _{OUT} = 1A, V _{IN} = 3V to 3.6V to 3V, t _R = t _F = 10μs (Note 6)	-50	--	50	mV
Switching Frequency	f _{SW}	Boost or Buck operation	--	2.2	--	MHz
Switching Frequency Range	f _{SW_RANGE}	Forced PWM operation, I _{OUT} = 100mA	0.5	--	3	MHz
Switching Frequency at Ultra-Sonic Mode	f _{SW_USC}	I _{OUT} = 1mA	30	--	--	kHz

Parameter	Symbol	Test Conditions	Min	Typ	Max	Unit
Minimum On-Time	tON_MIN		20	--	60	ns
Minimum Off-Time	tOFF_MIN		20	--	60	ns
Output Voltage Rising Time	tR(SS)	Output voltage ramp to output voltage 95%, L = 0.47μH, CIN = 10μF, COUT = 44μF	--	300	1000	μs
Enable Delay Time	tD(EN)	Enable pin logic-high to output voltage ramp, L = 0.47μH, CIN = 10μF, COUT = 44μF	--	220	300	μs
VSEL Delay Time	tD(VSEL)	Delay between rising edge of VSEL and start of DVS ramp	--	30	--	μs
Positive-Going Under-Voltage Threshold Voltage	UVP+		--	95	--	%
Negative-Going Under-Voltage Threshold Voltage	UVP-		--	90	--	%
Output Voltage Dynamic Voltage Scaling Slew Rate	DVS_SR	0x01, bit[1:0] = 00b	0.8	1	1.2	V/ms
		0x01, bit[1:0] = 01b	2	2.5	3	
		0x01, bit[1:0] = 10b	4	5	6	
		0x01, bit[1:0] = 11b	8	10	12	
Thermal Shutdown	TSD	(Note 6)	140	150	160	°C
Thermal Shutdown Hysteresis	ΔTSD	(Note 6)	--	20	--	°C

I²C Characteristics

Parameter	Symbol	Test Conditions	Min	Typ	Max	Unit
Logic Output Threshold Voltage (SCL, SDA, VSEL)	V _{I²C} COL		--	--	0.4	V
I ² C Work Voltage	V _{I²C} int		--	1.8	--	V
Input Current Each IO Pin	I _{IN} I ² C		-10	--	10	μA
Data Set-Up Time	t _{DS} I ² C		70	--	--	ns
SCL Clock Frequency	f _{CLK}	Standard mode	--	--	100	kHz
		Fast mode	--	--	400	
		Fast mode plus	--	--	1000	
Bus Free Time between Stop and Start Condition	t _{BUF}	Standard mode	4.7	--	--	μs
		Fast mode	1.3	--	--	
		Fast mode plus	0.5	--	--	
Hold Time (Repeated) START Condition	t _{HD} ;STA	Standard mode	4.7	--	--	μs
		Fast mode	0.6	--	--	
		Fast mode plus	0.26	--	--	

Parameter	Symbol	Test Conditions	Min	Typ	Max	Unit
Set-Up Time for a Repeated START Condition	t _{SU;STA}	Standard mode	4.7	--	--	μs
		Fast mode	0.6	--	--	
		Fast mode plus	0.26	--	--	
Data Hold Time	t _{HD;DAT}	Standard mode	0.1	--	--	ns
		Fast mode	0.1	--	--	
		Fast mode plus	0.1	--	--	
Set-Up Time for STOP Condition	t _{SU;STO}	Standard mode	4	--	--	μs
		Fast mode	0.6	--	--	
		Fast mode plus	0.26	--	--	
Data Valid Acknowledge Time	t _{VD;ACK}	Standard mode	--	--	3.45	μs
		Fast mode	--	--	0.9	
		Fast mode plus	--	--	0.45	
SDA Set-Up Time	t _{SU;DAT}	Standard mode	250	--	--	ns
		Fast mode	100	--	--	
		Fast mode plus	50	--	--	
Low Period of the SCL Clock	t _{LOW}	Standard mode	4.7	--	--	μs
		Fast mode	1.3	--	--	
		Fast mode plus	0.5	--	--	
High Period of the SCL Clock	t _{HIGH}	Standard mode	4	--	--	μs
		Fast mode	0.6	--	--	
		Fast mode plus	0.26	--	--	

Note 1. Stresses beyond those listed under “Absolute Maximum Ratings” may cause permanent damage to the device. These are stress ratings only, and functional operation of the device at these or any other conditions beyond those indicated in the operational sections of the specifications is not implied. Exposure to absolute maximum rating conditions may affect device reliability.

Note 2. θ_{JA} is measured under natural convection (still air) at T_A = 25°C with the component mounted on a high effective-thermal-conductivity four-layer test board on a JEDEC 51-7 thermal measurement standard.

Note 3. Devices are ESD sensitive. Handling precautions are recommended.

Note 4. The device is not guaranteed to function outside its operating conditions.

Note 5. Effective capacitance after DC bias effects have been considered.

Note 6. Guaranteed by design.

Note 7. The device can sustain the maximum recommended output current, Users must verify that the thermal performance of the end application can support the maximum output current.

Typical Application Circuit

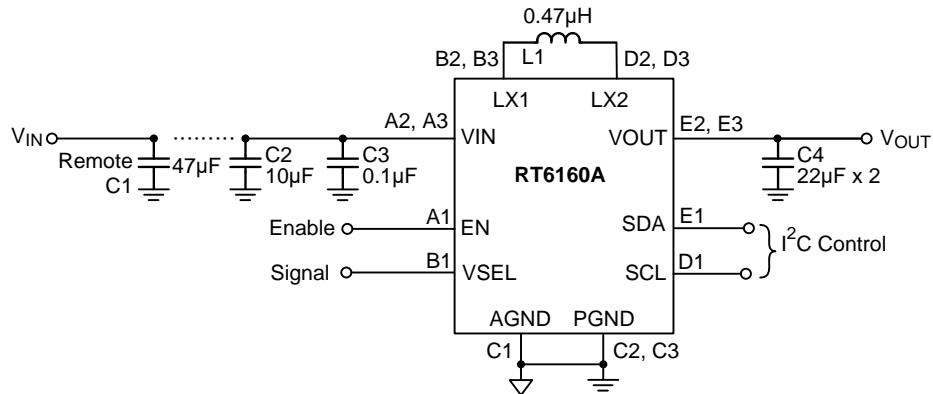

Table 1. Recommended Components Information (Note 8)

Reference	Part Number	Description	Package	Manufacturer
C1 (Note 9)	GRM32ER61C476KE15	47µF/16V/X5R	1210	Murata
C2	GRM155R60J106ME15	10µF/6.3V/X5R	0402	Murata
C3 (Note 10)	GRM033R60J104KE19D	0.1µF/6.3V/X5R	0201	Murata
C4	GRM188R61A226ME15D	22µF/10V/X5R	0603	Murata
L1	XFL4015-471MEC	0.47µH	4x4x1.5mm	Coilcraft

Note 8. All the input and output capacitors are the suggested values, referring to the effective capacitances, subject to any derating effect, like a DC bias.

Note 9. The decoupling capacitor C1 is Remote C_{OUT} capacitor. C1 is optional. The device is designed to operate with a DC supply voltage in the range 2.2V to 5.5V. If the input supply is more than a few centimeters from the device, we recommend you add some bulk capacitance to the ceramic bypass capacitors. A 47µF electrolytic capacitor is a typical selection for the bulk capacitance.

Note 10. The decoupling capacitor C3 is recommended to reduce any high frequency component on VIN bus. C3 is optional and used to filter any high frequency component on VIN bus.

Typical Operating Characteristics

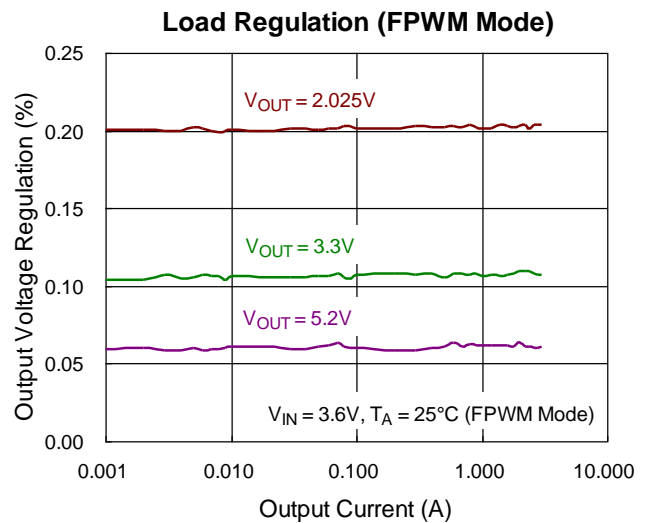
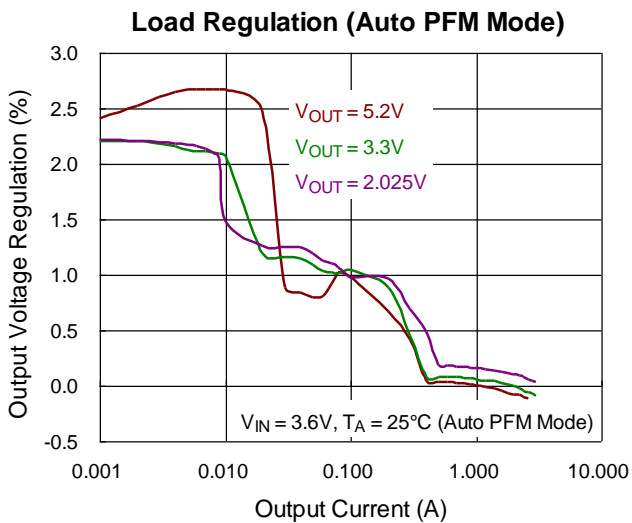
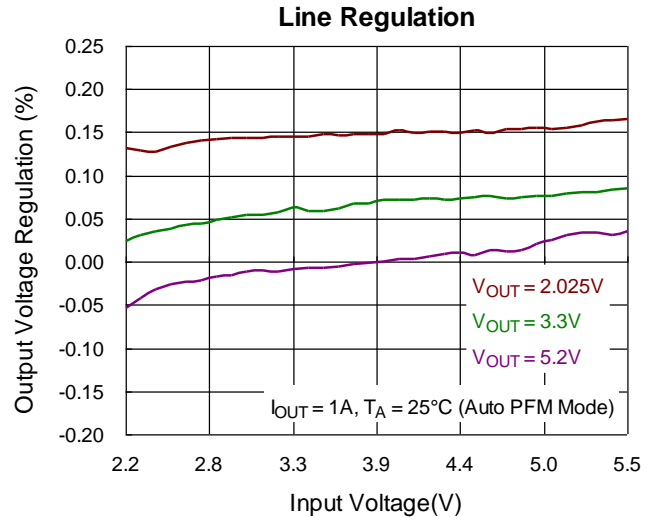
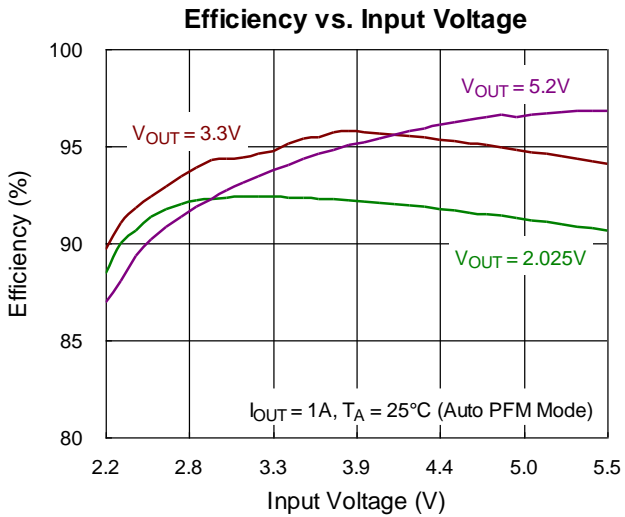
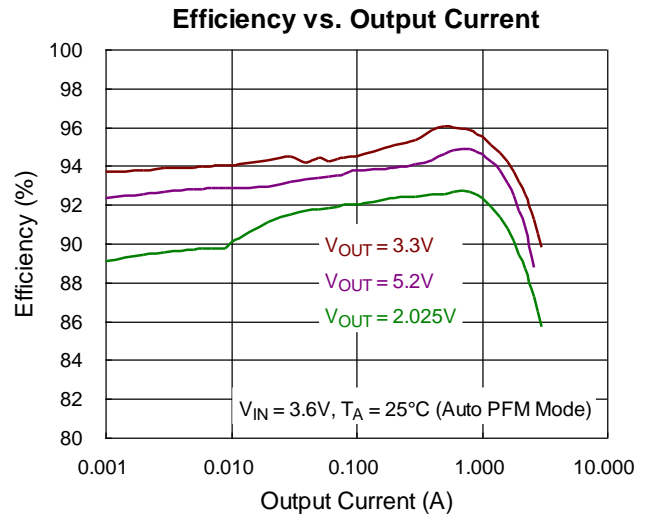
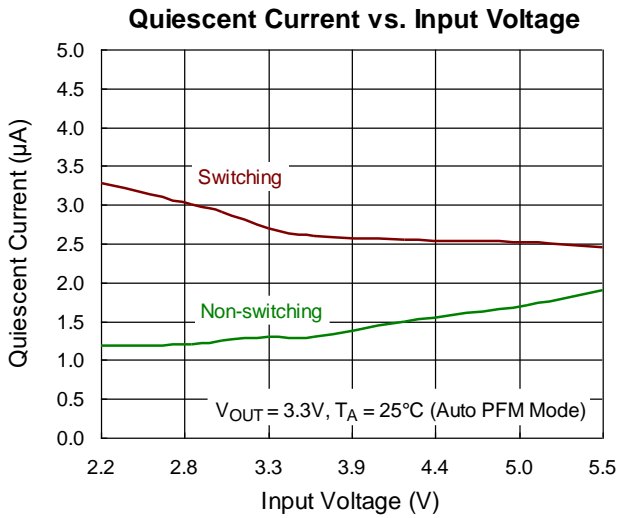

PFM Switching Waveforms (Buck Operation)

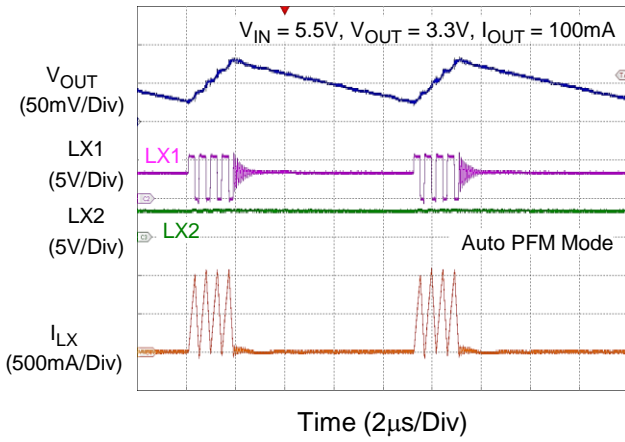

PFM Switching Waveforms (Buck-Boost Operation)

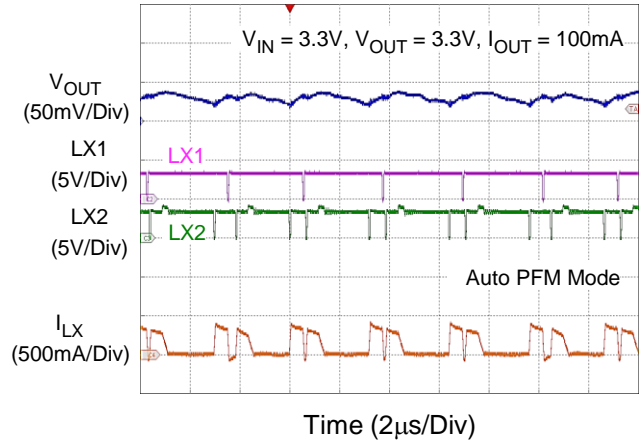

PFM Switching Waveforms (Boost Operation)

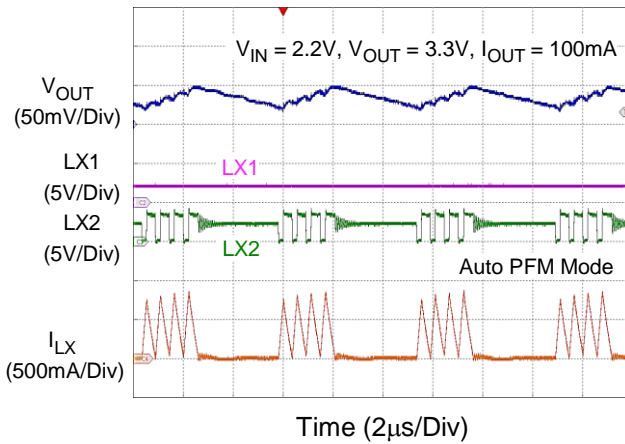

PWM Switching Waveforms (Buck Operation)

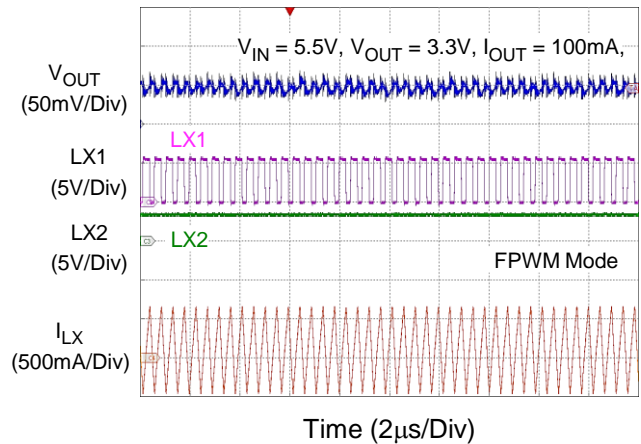

PWM Switching Waveforms (Buck-Boost Operation)

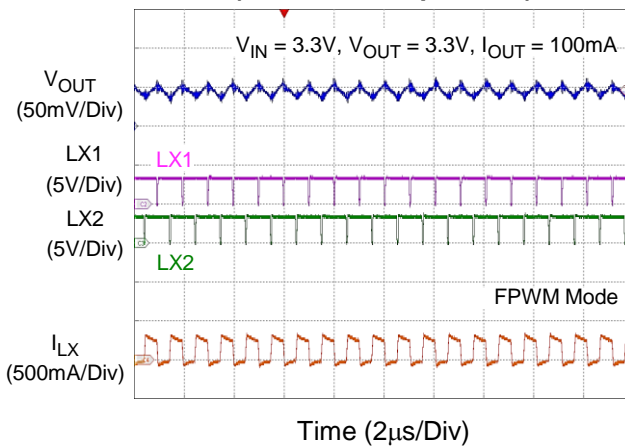

PWM Switching Waveforms (Boost Operation)

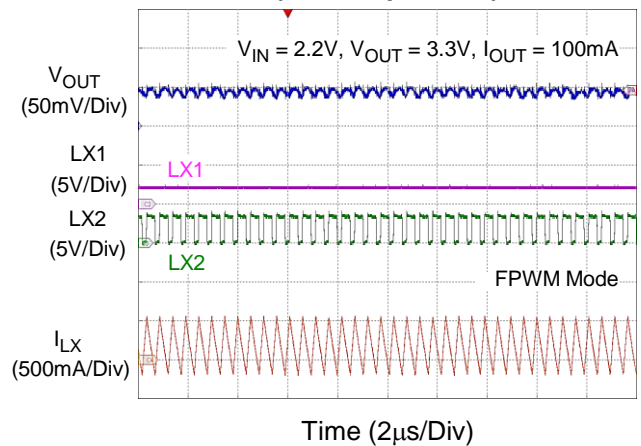

Line Transient Response (Light Load)

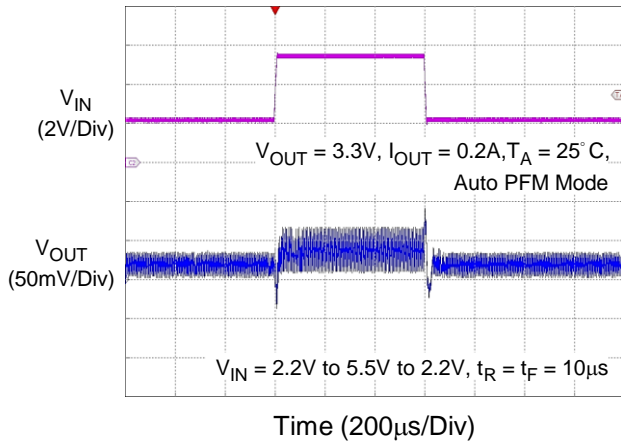

Line Transient Response (Heavy Load)

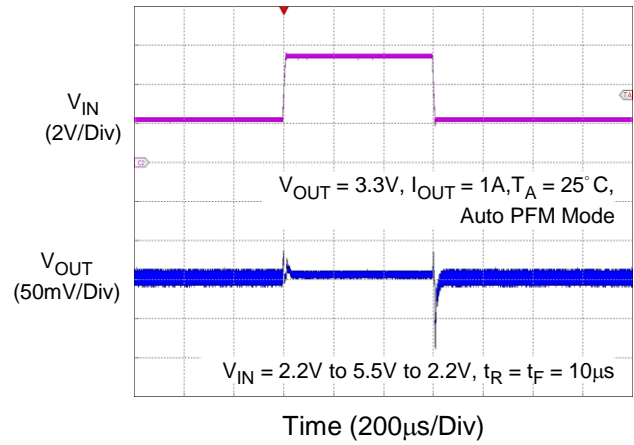

Line Transient Response (SPEC Condition)

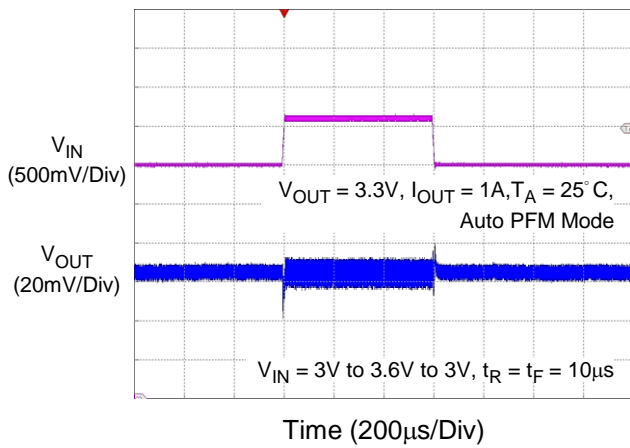

Load Transient Response (Buck)

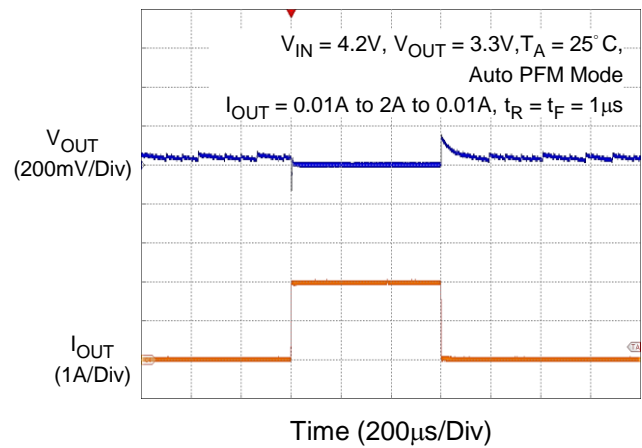

Load Transient Response (Buck-Boost)

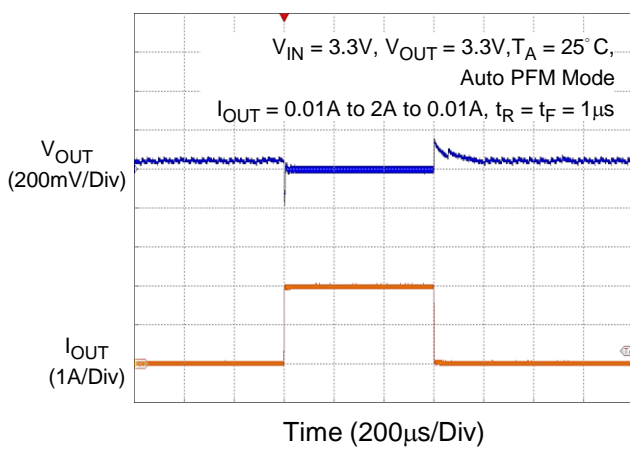

Load Transient Response (Boost)

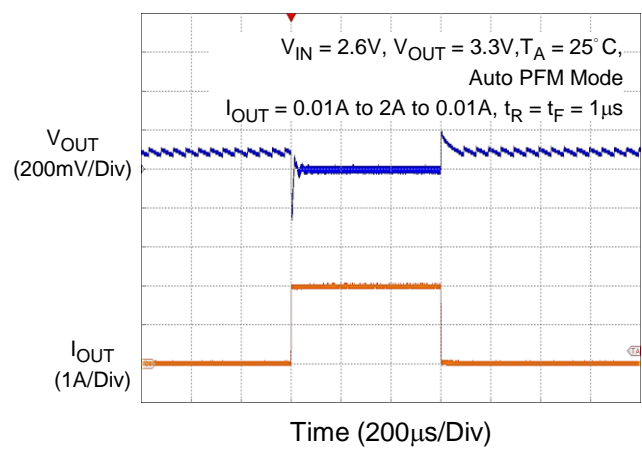

Load Transient Response (SPEC Condition1)

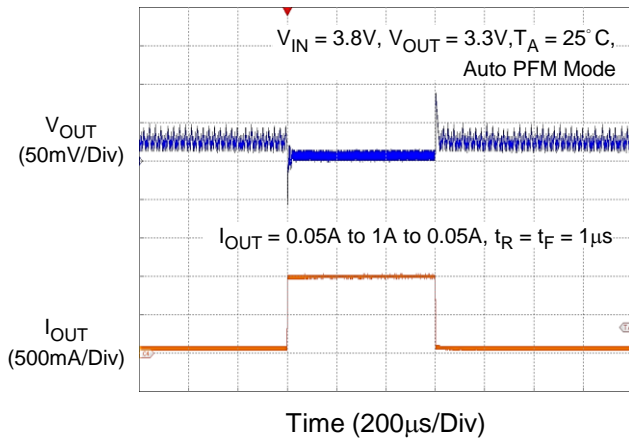

Load Transient Response (SPEC Condition2)

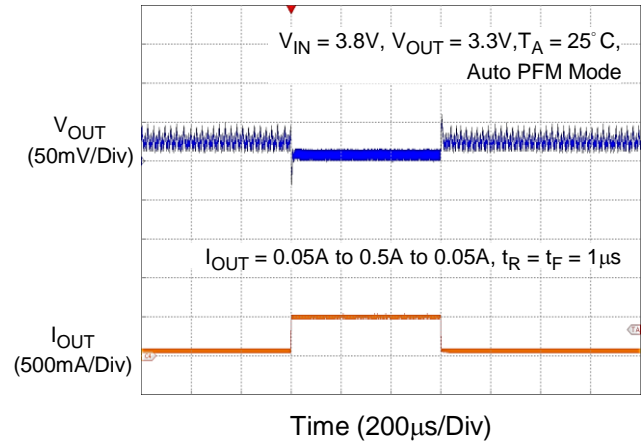

Start-Up Waveforms (Light Load)

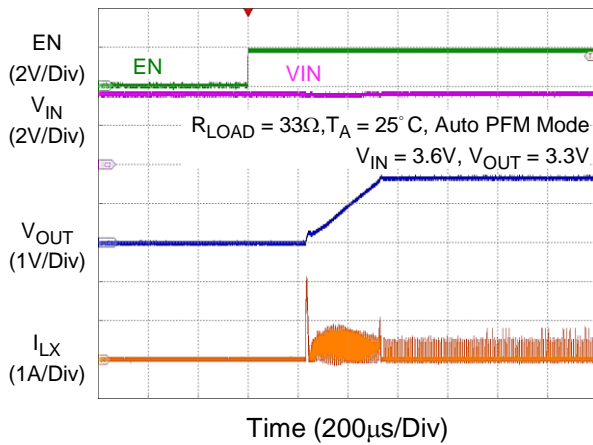

Start-Up Waveforms (Heavy Load)

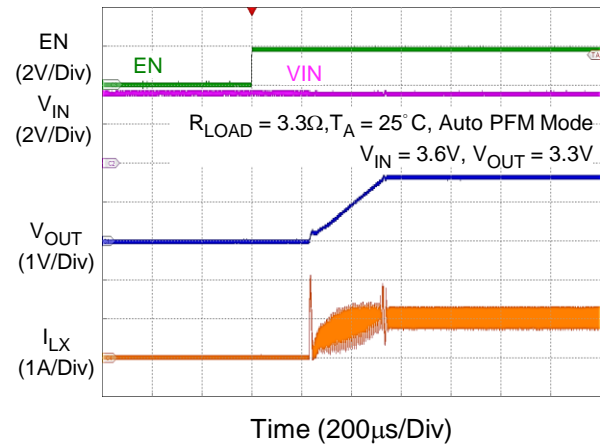

Dynamic Voltage Scaling (RPWM Function Disable)

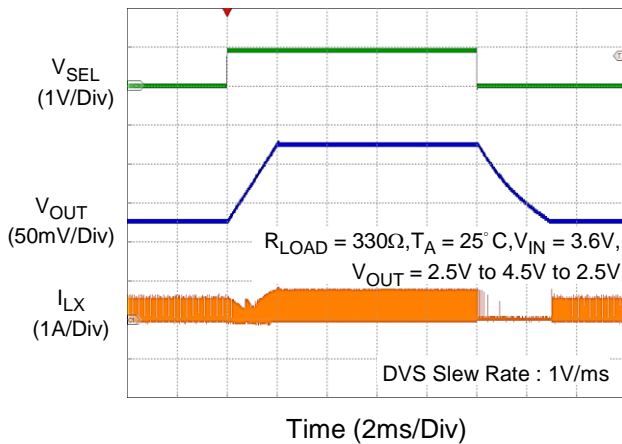

Dynamic Voltage Scaling (RPWM Function Enable)

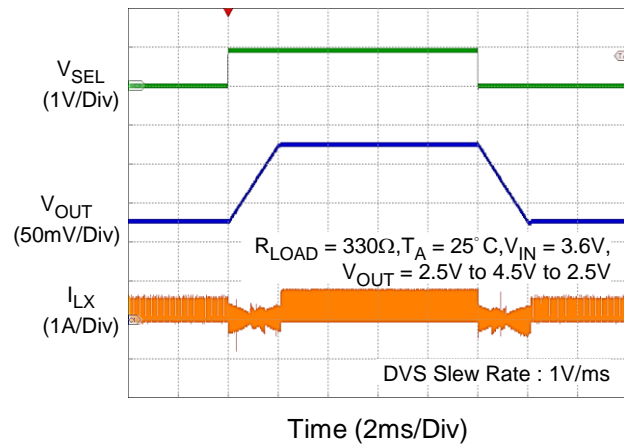

Line Sweep (Auto PFM Mode)

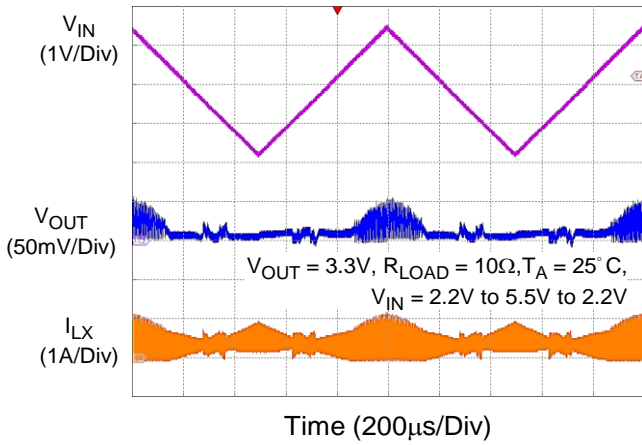

Line Sweep (FPWM Mode)

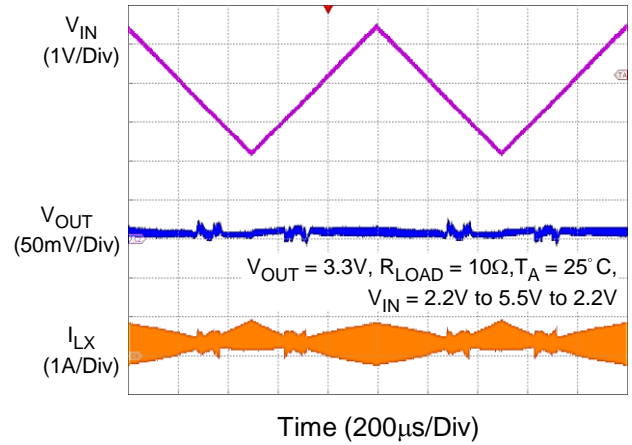

Output Short-Circuit Behavior

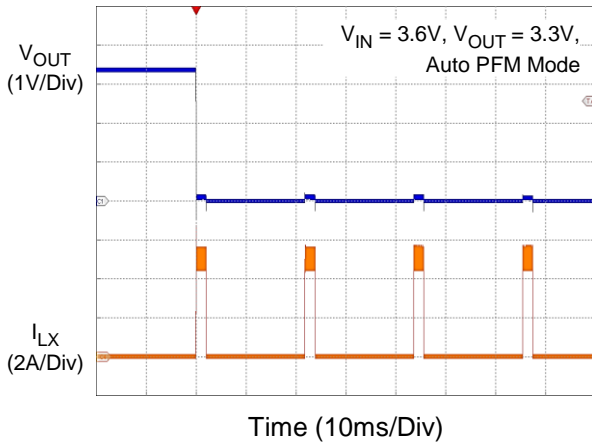

Output Voltage Accuracy

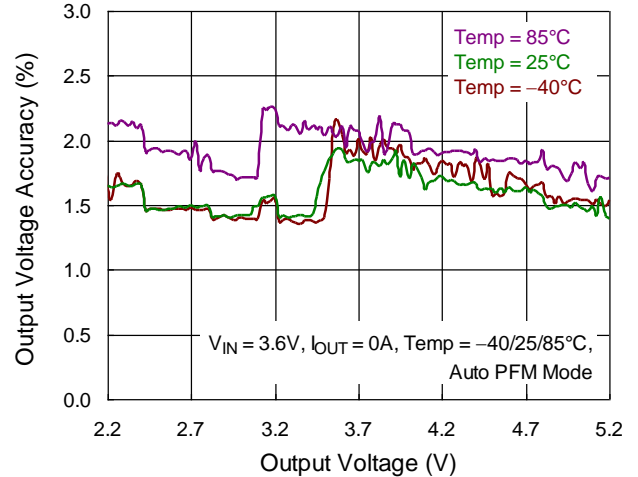

Switching Frequency vs. Input Voltage

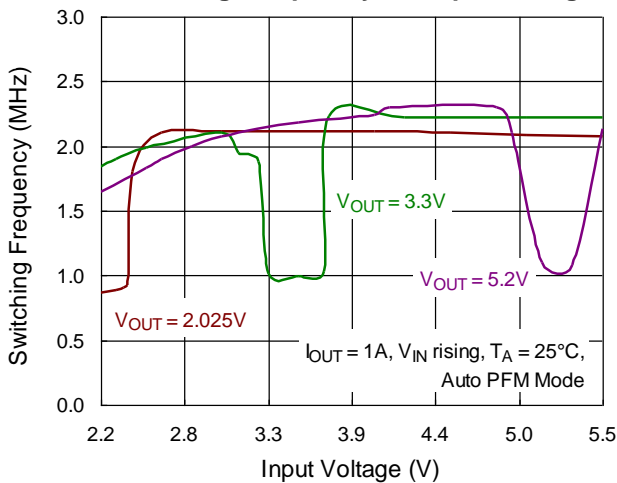

Maximum Output Current vs. Input Voltage

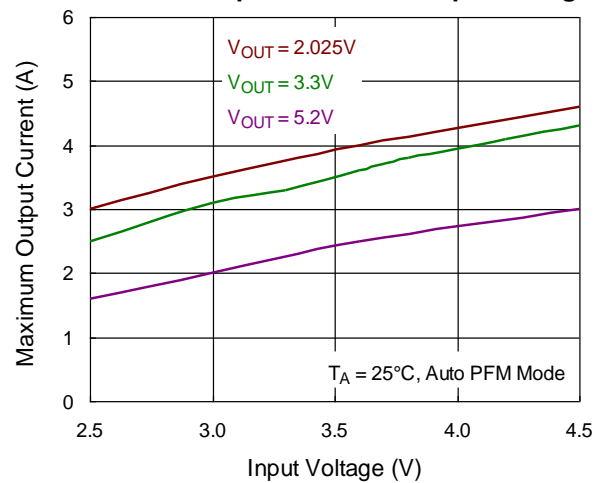

Application Information

Richtek's component specification does not include the following information in the Application Information section. Thereby no warranty is given regarding its validity and accuracy. Customers should take responsibility to verify their own designs and reserve suitable design margin to ensure the functional suitability of their components and systems.

The basic RT6160A application circuit is shown in Typical Application Circuit. External component selection is determined by the maximum load current and begins with the selection of the inductor value and operating frequency followed by C_{IN} and C_{OUT} .

Soft-Start

An internal current source charges an internal capacitor to build the soft-start ramp voltage. During the soft-start period, device sets \overline{PG} to "1" until V_{OUT} reach 99% of its setting voltage.

The rise time of the output voltage changes with the application circuit and the operating conditions. The output voltage rise time increases if

- The load current is large
- The output capacitance is large

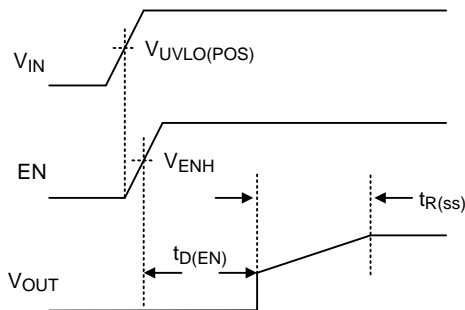

Figure 4. Soft-Start Sequence

Enable

The RT6160A provides an EN pin, as an external chip enable control, to enable or disable the device. If V_{EN} is held below a logic-low threshold voltage ($V_{ENH} - \Delta V_{EN}$), switching is inhibited even if the V_{IN} voltage is above V_{IN} under-voltage lockout threshold (V_{UVLO}). If V_{EN} is held below 0.4V, the converter will enter into shutdown mode, that is, the converter is disabled and will reset all registers to default value. During shutdown mode, the supply current can be reduced to I_{SHDN} ($1\mu A$ or below). It's recommend that the V_{IN} voltage is higher than

V_{UVLO} first, then the EN voltage rises above the logic-high threshold voltage (V_{ENH}) the device will be turned on, that is, switching being enabled and soft-start sequence being initiated.

Note that, there is a $100\mu s$ deglitch time for allowing I²C read/write when EN pin goes above logic-high threshold.

VSEL

$VSEL = L$ output voltage default setting is 3.3V that can be programmed by Address 0x04[6:0] V_{OUT1} .

$VSEL = H$ output voltage default setting is 3.45V that can be programmed by Address 0x05[6:0] V_{OUT2} .

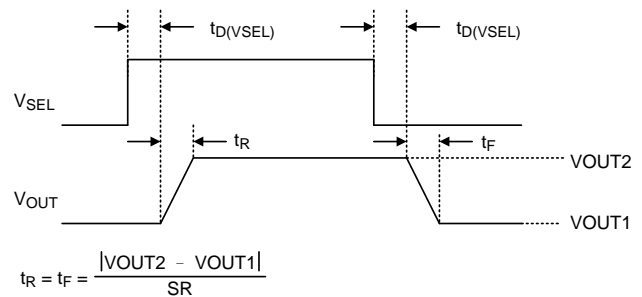

Figure 5. DVS Control the VSEL Pin

SR is the slew rate set by the (DVS Slew Rate) bits in the CONTROL register.

Auto PFM (Pulse Frequency Modulation) Mode

In order to save power and improve efficiency at low loads, the Buck/Boost operate in PFM (Pulse Frequency Modulation) mode as the inductor drops into DCM (Discontinuous Current Mode). The switching frequency is proportional to loading to reach output voltage regulation. When load increases and inductor current becomes continuous again, the Buck/Boost automatically goes back to PWM fixed frequency mode. Additionally, the RT6160A will enters DSLP (Deep Sleep) to reach input low quiescent current at no load. Auto PFM Mode is default mode.

FPWM (Forced Pulse Width Modulation) Mode

The switching frequency is forced into PWM mode operation. In this mode, the inductor current is in CCM (Continuous Current Mode) and the voltage is regulated by PWM.

To enable Forced-PWM operation, set the FPWM bit in the Control register to 1.

Ultra-Sonic Mode

To avoid acoustic noise problem when operation, the switching frequency is designed to be always higher than 30kHz even there is no load at output.

To enable Ultra-Sonic Mode operation, set the Ultra-Sonic Mode bit in the Control register to 1.

Ramp-PWM Function

If Ramp-PWM function is enabled, the device operates in forced-PWM when it ramps from one output voltage to another during dynamic voltage scaling. This function is useful if you want the device to operate in Auto PFM Mode but you want to make sure that dynamic voltage scaling ramps the output voltage up and down in a controlled way. If the device operates in Auto PFM Mode and Ramp-PWM is disabled, the devices cannot always control the ramp from a higher output voltage to a lower output voltage, because in Automatic PFM/PWM Mode the devices cannot sink current.

To enable Ramp-PWM function, set the RAMP bit in the control register to 1.

To disable Ramp-PWM function, clear the RAMP bit in the control register to 0.

Dynamically Voltage Scaling Control

The RT6160A supports programmable slew-rate control feature when increasing and decreasing the output voltage, as known as Dynamically Voltage Scaling (DVS). The ramp slew-rate can be set to 1V/ms, 2.5V/ms, 5V/ms or 10V/ms through bit1 and bit0 of control register. Moreover, the operation mode during DVS region can be adjusted through control register bit2. When the device operates in Auto PFM/PWM mode, if the bit2 is set to 1, the device will change to Forced PWM mode operation during DVS region and back to auto PFM/PWM mode after reaching target output

voltage. And the device will keep auto PFM/PWM mode during DVS region if the bit2 of control register is set to 0.

Output Discharge

The device actively discharges the output when the EN pin is low.

VOUT Selection

The RT6160A has programmable V_{OUT} from 2.025V to 5.2V with 25mV resolution.

The output voltage can be set by VOUTx register bit and the output voltage is given by the following equation :

$$V_{OUT} = 2.025V + V_{OUTx} \times 25mV$$

For example :

if VOUTx = 110011 (51 decimal), then

$$V_{OUT} = 2.025V + 51 \times 25mV = 2.025V + 1.275V = 3.3V.$$

The RT6160A also has external VSEL pin to select VOUT1(0X04) or VOUT2(0X05). Pulling VSEL to high is for VOUT2 and pulling VSEL to low is for VOUT1.

Upon POR, VOUT1 and VOUT2 are reset to their default voltages.

Power-Good Comparator

When a power-not-good condition occurs, the device sets the \overline{PG} bit in the Status register to 1. The device clears the \overline{PG} bit to 0 if you read the Status register when a power-good condition exists.

Auto-Zero Current Detector

The auto-zero current detector circuit senses the LX1 and LX2 waveform to adjust the zero current threshold voltage. When the current of low side MOSFET decrease to the zero current threshold. The low-side MOSFET turns off to prevent negative inductor current. In this way, the zero current threshold can adjust for different condition to get better efficiency.

Load Disconnect

During device shutdown, the input is disconnected from the output. This prevents any current flow from the output to the input or from the input to the output.

PWM Frequency and Adaptive On-Time Control

The on-time can be roughly estimated by the equation :

$$t_{ON} = \frac{V_{OUT}}{V_{IN}} \times \frac{1}{f_{SW}}$$

where f_{SW} is nominal 2.2MHz.

Inductor Selection

Inductor value choose will effect transient, ripple and other performance. The RT6160A recommended nominal inductance value is 0.47μH to achieve advantage performance.

The inductor value and operating frequency determine the ripple current according to a specific input and output voltage. The ripple current ΔI_L increases with higher V_{IN} and decreases with higher inductance.

$$\Delta I_L = \left(\frac{V_{OUT}}{f_{SW} \times L} \right) \times \left(1 - \frac{V_{OUT}}{V_{IN}} \right)$$

Having a lower ripple current reduces not only the ESR losses in the output capacitors but also the output voltage ripple. High frequency with small ripple current can achieve the highest efficiency operation. However, it requires a large inductor to achieve this goal.

For the ripple current selection, the value of ΔI_L which is I_{MAX} multiplied by 0.3 will be a reasonable starting point.

The largest ripple current occurs at the highest V_{IN} . To guarantee that the ripple current stays below the specified maximum, the inductor value should be chosen according to the following equation :

$$L = \left(\frac{V_{OUT}}{f_{SW} \times \Delta I_L(MAX)} \right) \times \left(1 - \frac{V_{OUT}}{V_{IN(MAX)}} \right)$$

The inductor's current rating (caused a 40°C temperature rising from 25°C ambient) should be greater than the maximum load current and its saturation current should be greater than the short circuit peak current limit.

Input Capacitor Selection

Steady state and transient response operation performance also depend on input voltage stability or not. The RT6160A at least a 10μF input capacitor is recommended to prevent input voltage instability with application operation. And that suggest placed as close as possible to the V_{IN} and GND pins of the IC is recommended. If the input supply is more than a few centimeters from the device, we recommend you add some bulk capacitance to the ceramic bypass capacitors. A 47μF electrolytic capacitor is a typical selection for the bulk capacitance.

Output Capacitor Selection

The ripple voltage is an important index for choosing output capacitor. This portion consists of two parts. One is the product of ripple current with the ESR of the output capacitor, while the other part is formed by the charging and discharging process of the output capacitor.

Output capacitor is selected according to output ripple which is calculated as below equation.

$$\Delta V_{OUT} = \Delta V_{ESR} + \Delta V_{OUTCAP}$$

$$\Delta V_{ESR} = I_{CRMS} \times R_{CESR}$$

$$\Delta V_{OUTCAP} = \frac{I_{OUT} \times Duty}{f_{SW} \times C_{MIN}}$$

User can use equation choose capacitor to meeting systems ripple specification. And at least 22μF x 2 capacitors is recommended to matching application with V_{OUT} ripple request and stability performance.

Table 2. Protection Trigger Condition and Behavior

The RT6160A features some protections, such as OCP, OVP, UVLO, OTP and UVP. As the table shown, it is described the protection actions.

Protection Type	Threshold Refer to Electrical Spec.	Deglintch Time	Protection Method	Reset Method
OCP (Note 11)	$I_L > 5A$	0	Turn off Boost LG or Turn off Buck UG	$I_L < 4.5A$
UVLO	$V_{IN} < 2.08V$ (max)	0	Turn off all	$V_{IN} > 2.17V$ (max)
OTP	$TEMP > 150^{\circ}C$	0	Turn off all	OTP Hysteresis = $20^{\circ}C$
OVP	$V_{OUT} > 6V$	0	Turn off all	$V_{OUT} < 5.6V$
UVP	$V_{OUT} < 0.9 \times V_{OUT_Target}$	2ms	Turn off all	$V_{OUT} > 0.95 \times V_{OUT_Target}$

Note 11. Turn off all switches when OCP event occurs and is continuing for 2ms.

Over-Current Protection

The OCP function is implemented by UGATE and LGATE. When the inductor current reaches the UGATE current limit threshold, the high-side MOSFET will be turned-off. The low-side MOSFET turns on to discharge the inductor current until the inductor current trips below the LGATE current limit threshold. After UGATE current limit triggered, the max inductor current is decided by the inductor current rising rate and the response delay time of the internal network.

Input UVLO Protection

In addition to the EN pin, the RT6160A also provides enable control through the VIN pin. If VEN rises above VENH first, switching will still be inhibited until the VIN voltage rises above VUVLO. It is to ensure that the internal regulator is ready so that operation with not-fully-enhanced internal MOSFET switches can be prevented. After the device is powered up, if the VIN voltage goes below the UVLO falling threshold voltage (VUVLO - ΔVUVLO), this switching will be inhibited; if VIN voltage rises above the UVLO rising threshold (VUVLO), the device will resume switching.

Over-Temperature Protection

When the junction temperature exceeds the OTP threshold value, the IC will shut down the switching operation. Once the junction temperature cools down and is lower than the OTP lower threshold, the converter will automatically resume switching. When the device detects an over-temperature condition, it sets the

TSD bit in the Status register to 1. The device clears the TSD bit to 0 if you read the Status register when the junction temperature of the device is less than 130°C.

Over-Voltage Protection

When the VOUT pin is floating, the device will trigger the over-voltage protection to avoid the output voltage exceeding critical values for device. In case it reaches the OVP threshold, the device will regulate the output voltage to this value.

Under-Voltage Protection

The RT6160A provides Hiccup Mode for Under-Voltage Protection (UVP). When the VOUT voltage drops below 90% of Target VOUT, the UVP function will be triggered to shut down switching operation. If the UVP condition remains for a period, the RT6160A will retry to build up output voltage automatically. When the UVP condition is removed, the converter will soft-start to target voltage and resume normal operation.

Thermal Considerations

The junction temperature should never exceed the absolute maximum junction temperature TJ(MAX), listed under Absolute Maximum Ratings, to avoid permanent damage to the device. The maximum allowable power dissipation depends on the thermal resistance of the IC package, the PCB layout, the rate of surrounding airflow, and the difference between the junction and ambient temperatures. The maximum power dissipation can be calculated using the following formula :

$$P_{D(MAX)} = (T_{J(MAX)} - T_A) / \theta_{JA}$$

where $T_{J(MAX)}$ is the maximum junction temperature, T_A is the ambient temperature, and θ_{JA} is the junction-to-ambient thermal resistance.

For continuous operation, the maximum operating junction temperature indicated under Recommended Operating Conditions is 125°C. The junction-to-ambient thermal resistance, θ_{JA} , is highly package dependent. For a WL-CSP-15B 1.4x2.3 (BSC) package, the thermal resistance, θ_{JA} , is 53°C/W on a standard JEDEC 51-7 high effective-thermal conductivity four-layer test board. The maximum power dissipation at $T_A = 25^\circ\text{C}$ can be calculated as below :

$$P_{D(MAX)} = (125^\circ\text{C} - 25^\circ\text{C}) / (53^\circ\text{C/W}) = 1.88\text{W for a WL-CSP-15B 1.4x2.3 package.}$$

The maximum power dissipation depends on the operating ambient temperature for the fixed $T_{J(MAX)}$ and the thermal resistance, θ_{JA} . The derating curves in Figure 6 allows the designer to see the effect of rising ambient temperature on the maximum power dissipation.

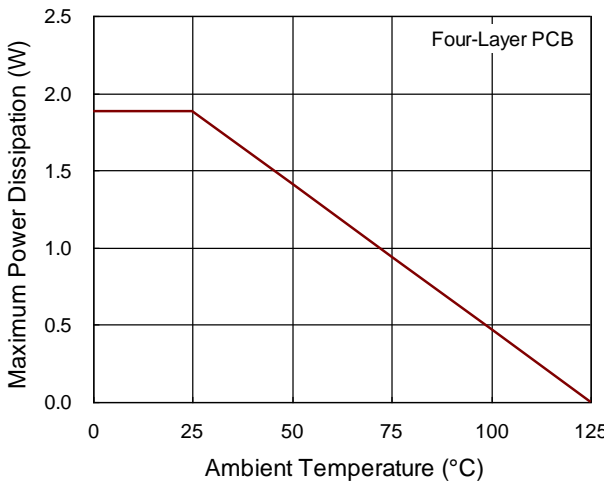

Figure 6. Derating Curve of Maximum Power Dissipation

Layout Considerations

For best performance of the RT6160A, the following layout guidelines must be strictly followed.

- ▶ Input capacitor must be placed as close as possible to IC to minimize the power loop area. A typical 0.1µF decoupling capacitor is recommended to reduce power loop area and any high frequency component on VIN.
- ▶ Switching node (LX1 and LX2) are with high frequency voltage swing and should be kept at small area. Keep analog components away from the LX1 and LX2 node to prevent stray capacitive noise pickup.
- ▶ Keep every power trace connected to pin as wide as possible for improving thermal dissipation.
- ▶ The AGND pin is suggested to connect to 2nd GND plate through top to 2nd via.

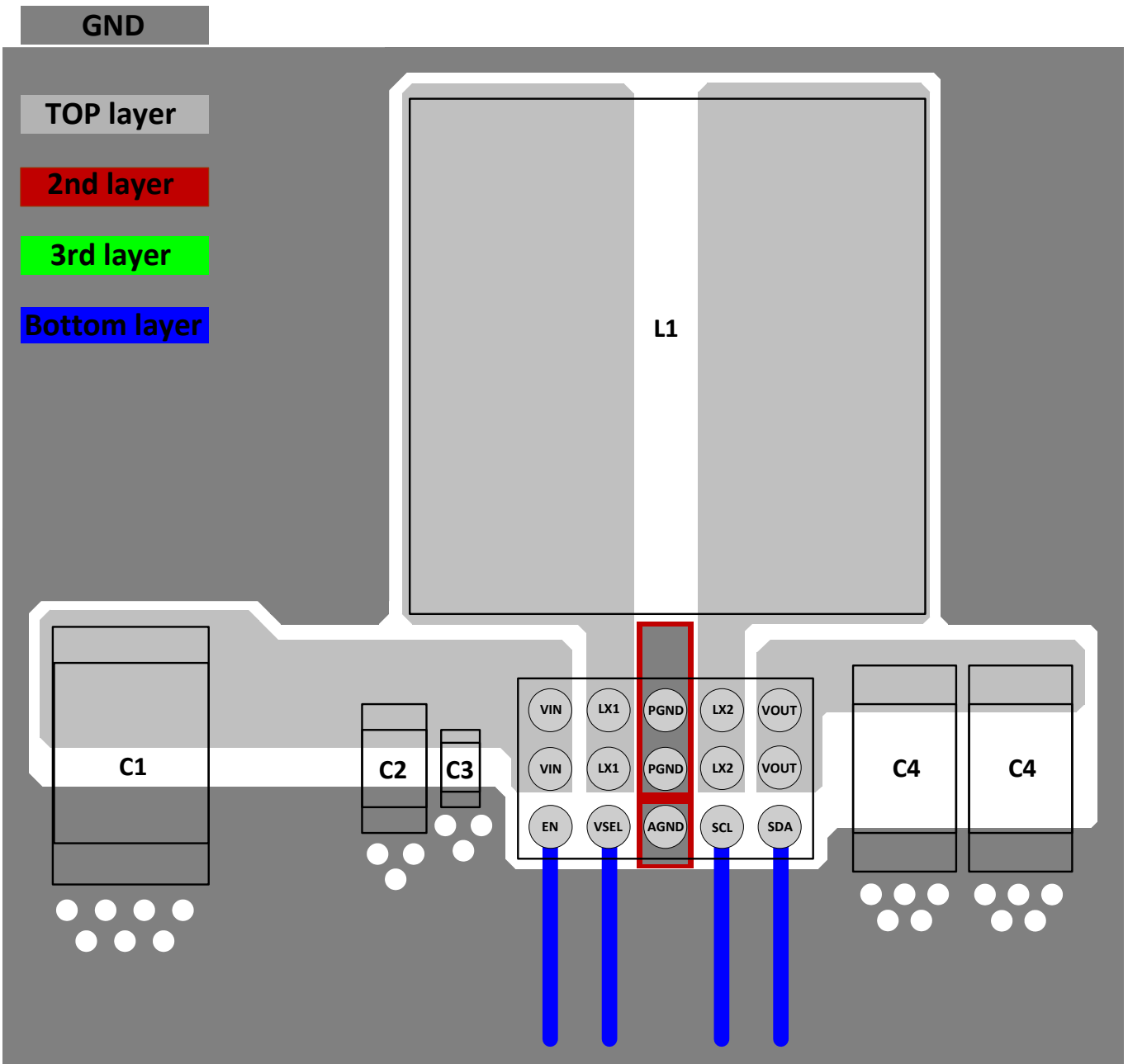

Figure 7. Layout Guide

I²C Interface

The following table shows the RT6160A slave address 0x75(7bit).

RT6160A I ² C Slave Address (75H)			
MSB	LSB	R/W bit	R/W
111010	1	1/0	EB/EA

The I²C interface bus must be connect a resistor 2.2kΩ to power node and independent connection to processor, individually. The I²C timing diagrams are listed below.

Read and Write Function

Read single byte of data from Register

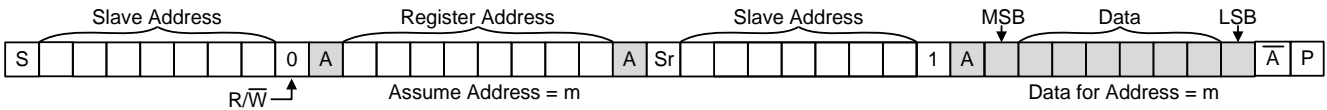

Read N bytes of data from Registers

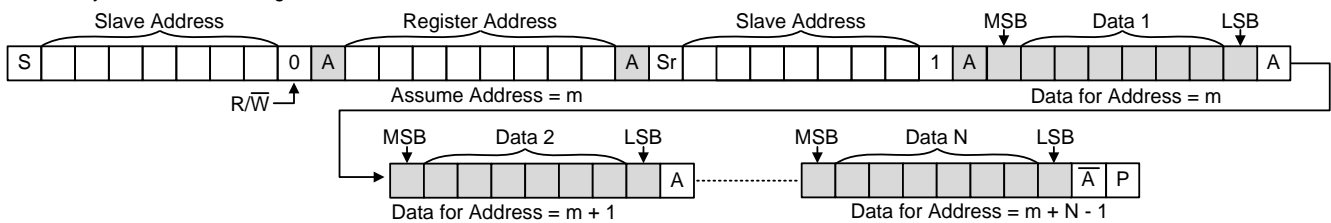

Write single byte of data to Register



Write N bytes of data to Registers

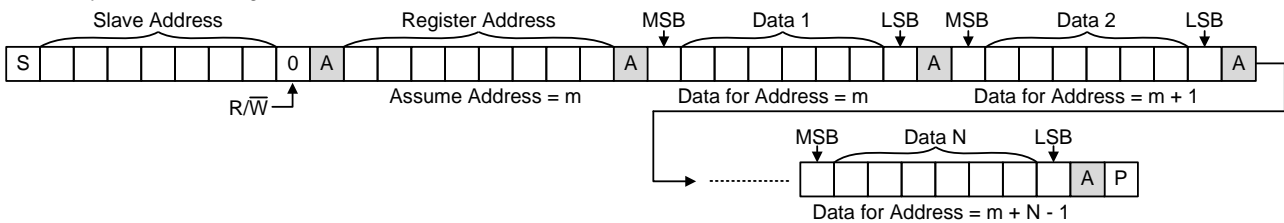

□ Driven by Master, ■ Driven by Slave, P Stop, S Start, Sr Repeat Start

I²C Waveform Information

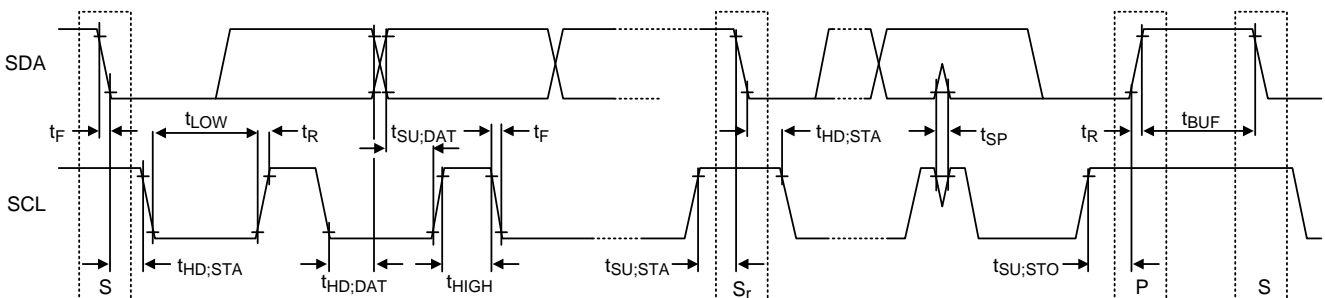

Figure 8. I²C Read and Write Stream and Timing Diagram

Register Table Lists

Name	Address	Description
CONTROL	0x01	Output pull-down slew rate control MODE function control DVS slew rate function control
STATUS	0x02	Read IC status
DEVID	0x03	Device Identity
VOUT1	0x04	Output Voltage 1 when the VSEL pin is low
VOUT2	0x05	Output Voltage 2 when the VSEL pin is High

Register Description

I²C Slave address = 1110101 (75H)

I²C Register Map

R : Read Only

RW : Read and Write

Address 0x01	CONTROL							
Bits	7	6	5	4	3	2	1	0
Name	Reserved	I ² C_SDA_SLEW		Ultra-Sonic Mode	Forced PWM	Ramp PWM	DVS Slew Rate	
Reset	0	0	0	0	0	0	0	0
Type	R	R/W	R/W	R/W	R/W	R/W	R/W	R/W
Address 0x02	STATUS							
Bits	7	6	5	4	3	2	1	0
Name	Reserved			HD	UV	OC	TSD	PG
Reset	0	0	0	0	0	0	0	0
Type	R	R	R	R	R	R	R	R
Address 0x03	DEVID							
Bits	7	6	5	4	3	2	1	0
Name	Manufacturer				Major		Minor	
Reset	1	0	1	0	1	0	0	0
Type	R	R	R	R	R	R	R	R
Address 0x04	VOUT1							
Bits	7	6	5	4	3	2	1	0
Name	Reserved	VOUT1						
Reset	0	0	1	1	0	0	1	1
Type	R	R/W	R/W	R/W	R/W	R/W	R/W	R/W
Address 0x05	VOUT2							
Bits	7	6	5	4	3	2	1	0
Name	Reserved	VOUT2						
Reset	0	0	1	1	1	0	0	1
Type	R	R/W	R/W	R/W	R/W	R/W	R/W	R/W

Address	Register Name	Bit	Bit Name	Default	Type	Description
0x01	CONTROL	7	Reserved	0	R	Reserved
		6:5	I ² C_SDA_SLEW	00	R/W	SDA pin output pull-down slew rate 00 : High (default) 01 : Medium 10 : Low 11 : Very low
		4	Ultra-Sonic Mode	0	R/W	This bit controls the ultra-sonic mode function. 0 : Ultra-Sonic mode disabled (default) 1 : Ultra-Sonic mode enabled
		3	Forced PWM	0	R/W	This bit controls the forced-PWM mode function. 0 : Forced PWM operation disabled (default) 1 : Forced PWM operation enabled
		2	Ramp PWM	0	R/W	This bit controls the ramp-PWM function. 0 : Ramp-PWM operation disabled (default) 1 : Ramp-PWM operation enabled
		1:0	DVS Slew Rate	00	R/W	These bits control the slew rate of the DVS function. 00 : 1.0V/ms (default) 01 : 2.5V/ms 10 : 5.0V/ms 11 : 10.0V/ms
Address	Register Name	Bit	Bit Name	Default	Type	Description
0x02	STATUS	7:5	Reserved	000	R	Reserved
		4	HD	0	R	This bit shows the status of the hot-die function. 0 : Normal operation (default) 1 : An hot-die event was detected
		3	UV	0	R	This bit shows the status of the under voltage function. 0 : Normal operation (default) 1 : An under-voltage event was detected
		2	OC	0	R	This bit shows the status of the over current function. 0 : Normal operation (default) 1 : An over-current event was detected
		1	TSD	0	R	This bit shows the status of the thermal shutdown function. 0 : Temperature good (default) 1 : An over-temperature event was detected
		0	$\overline{\text{PG}}$	0	R	This bit shows the status of the power-good comparator. 0 : Power-good (default) 1 : A power-not-good was detected

Address	Register Name	Bit	Bit Name	Default	Type	Description
0x03	DEVID	7:4	Manufacturer	1010	R	These bits identify the device manufacturer. 1010 : Richtek (default)
		3:2	Major	10	R	These bits identify the major silicon revision. 00 : A (initial silicon) 01 : B (first major revision) 10 : C (second major revision) (default) 11 : D (third major revision)
		1:0	Minor	00	R	These bits identify the minor silicon revision. 00 : 0 (initial silicon) (default) 01 : 1 (first minor revision) 10 : 2 (second minor revision) 11 : 3 (third minor revision)
Address	Register Name	Bit	Bit Name	Default	Type	Description
0x04	VOUT1	7	Reserved	0	R	Reserved
		6:0	VOUT1	0110011	R/W	These bits set the output voltage when the VSEL pin is low. 0000000 : VOUT = 2.025V 0000001 : VOUT = 2.05V 0000010 : VOUT = 2.075V ... 0110011 : VOUT = 3.3V (default) ... 1111101 : VOUT = 5.15V 1111110 : VOUT = 5.175V 1111111 : VOUT = 5.2V
Address	Register Name	Bit	Bit Name	Default	Type	Description
0x05	VOUT2	7	Reserved	0	R	Reserved
		6:0	VOUT2	0111001	R/W	These bits set the output voltage when the VSEL pin is High. 0000000 : VOUT = 2.025V 0000001 : VOUT = 2.05V 0000010 : VOUT = 2.075V ... 0111001 : VOUT = 3.45V (default) ... 1111101 : VOUT = 5.15V 1111110 : VOUT = 5.175V 1111111 : VOUT = 5.2V

Table 3. Register VOUT1/VOUT2[6:0] vs. Output Voltage

VOUT1 Address = 0x04, Output Voltage 1 when the VSEL pin is low.

VOUT2 Address = 0x05, Output Voltage 2 when the VSEL pin is high.

Register VOUT[6:0]	Output Voltage (V)	Register VOUT[6:0]	Output Voltage (V)	Register VOUT[6:0]	Output Voltage (V)	Register VOUT[6:0]	Output Voltage (V)
0000000	2.025	0100000	2.825	1000000	3.625	1100000	4.425
0000001	2.05	0100001	2.85	1000001	3.65	1100001	4.45
0000010	2.075	0100010	2.875	1000010	3.675	1100010	4.475
0000011	2.1	0100011	2.9	1000011	3.7	1100011	4.5
0000100	2.125	0100100	2.925	1000100	3.725	1100100	4.525
0000101	2.15	0100101	2.95	1000101	3.75	1100101	4.55
0000110	2.175	0100110	2.975	1000110	3.775	1100110	4.575
0000111	2.2	0100111	3	1000111	3.8	1100111	4.6
0001000	2.225	0101000	3.025	1001000	3.825	1101000	4.625
0001001	2.25	0101001	3.05	1001001	3.85	1101001	4.65
0001010	2.275	0101010	3.075	1001010	3.875	1101010	4.675
0001011	2.3	0101011	3.1	1001011	3.9	1101011	4.7
0001100	2.325	0101100	3.125	1001100	3.925	1101100	4.725
0001101	2.35	0101101	3.15	1001101	3.95	1101101	4.75
0001110	2.375	0101110	3.175	1001110	3.975	1101110	4.775
0001111	2.4	0101111	3.2	1001111	4	1101111	4.8
0010000	2.425	0110000	3.225	1010000	4.025	1110000	4.825
0010001	2.45	0110001	3.25	1010001	4.05	1110001	4.85
0010010	2.475	0110010	3.275	1010010	4.075	1110010	4.875
0010011	2.5	0110011	3.3	1010011	4.1	1110011	4.9
0010100	2.525	0110100	3.325	1010100	4.125	1110100	4.925
0010101	2.55	0110101	3.35	1010101	4.15	1110101	4.95
0010110	2.575	0110110	3.375	1010110	4.175	1110110	4.975
0010111	2.6	0110111	3.4	1010111	4.2	1110111	5
0011000	2.625	0111000	3.425	1011000	4.225	1111000	5.025
0011001	2.65	0111001	3.45	1011001	4.25	1111001	5.05
0011010	2.675	0111010	3.475	1011010	4.275	1111010	5.075
0011011	2.7	0111011	3.5	1011011	4.3	1111011	5.1
0011100	2.725	0111100	3.525	1011100	4.325	1111100	5.125
0011101	2.75	0111101	3.55	1011101	4.35	1111101	5.15
0011110	2.775	0111110	3.575	1011110	4.375	1111110	5.175
0011111	2.8	0111111	3.6	1011111	4.4	1111111	5.2

Outline Dimension

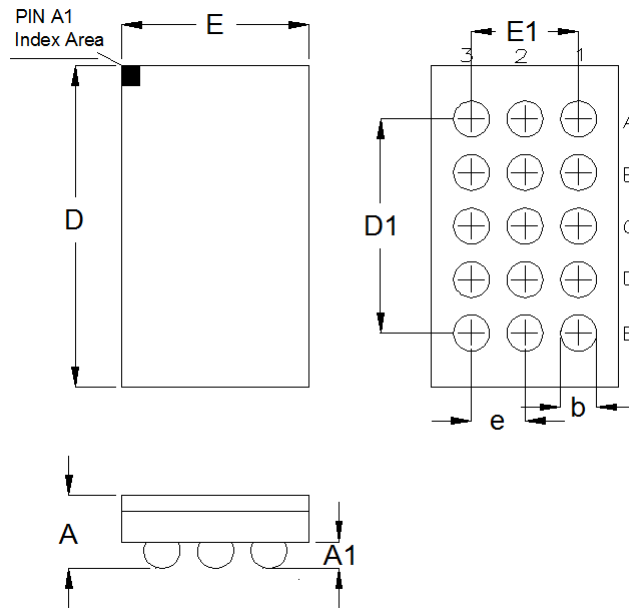

Symbol	Dimensions In Millimeters		Dimensions In Inches	
	Min	Max	Min	Max
A	0.500	0.600	0.020	0.024
A1	0.170	0.230	0.007	0.009
b	0.240	0.300	0.009	0.012
D	2.260	2.340	0.089	0.092
D1	1.600		0.063	
E	1.360	1.440	0.054	0.057
E1	0.800		0.031	
e	0.400		0.016	

15B WL-CSP 1.4x2.3 Package (BSC)

Footprint Information

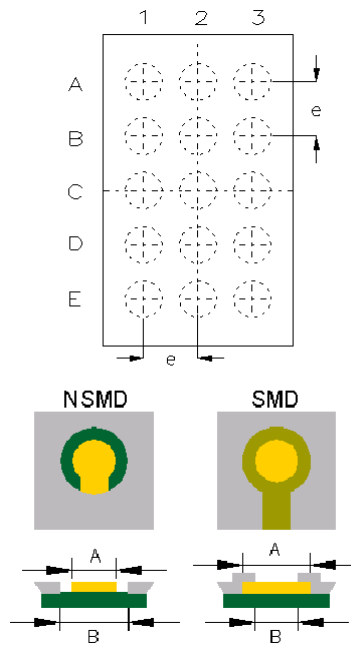

Package	Number of Pin	Type	Footprint Dimension (mm)			Tolerance
			e	A	B	
WL-CSP1.4x2.3-15(BSC)	15	NSMD	0.400	0.240	0.340	±0.025
		SMD		0.270	0.240	

Packing Information

Tape and Reel Data

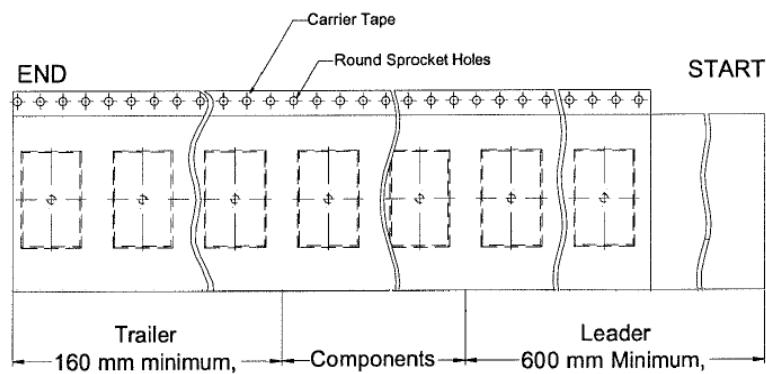
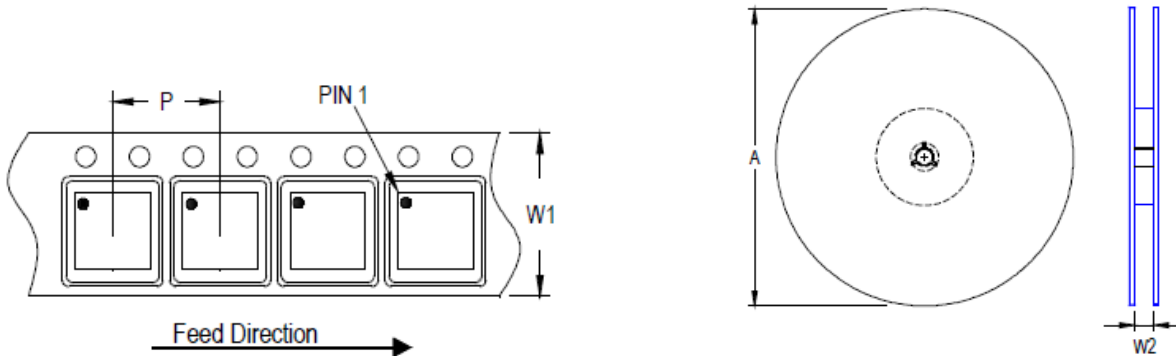



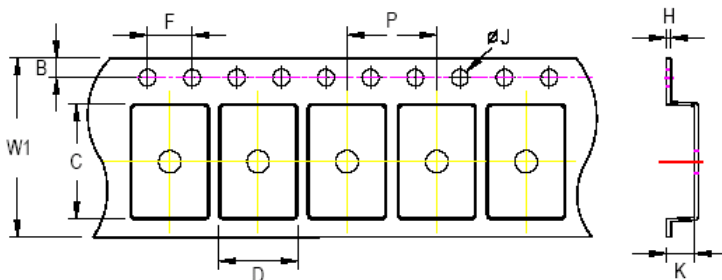

Package Type	Tape Size (W1) (mm)	Pocket Pitch (P) (mm)	Reel Size (A)		Units per Reel	Trailer (mm)	Leader (mm)	Reel Width (W2) Min./Max. (mm)
			(mm)	(in)				
WL-CSP 1.4x2.3	8	4	180	7	3,000	160	600	8.4/9.9



C, D and K are determined by component size.
The clearance between the components and the cavity is as follows:
- For 8mm carrier tape: 0.5mm max.

Tape Size	W1		P		B		F		ØJ		H
	Max.	Min.	Max.	Min.	Max.	Min.	Max.	Min.	Max.	Max.	
8mm	8.3mm	3.9mm	4.1mm	1.65mm	1.85mm	3.9mm	4.1mm	1.5mm	1.6mm	0.6mm	

Tape and Reel Packing

Step	Photo/Description	Step	Photo/Description
1	 <p>Reel 7"</p>	4	 <p>12 inner boxes per outer box</p>
2	 <p>Packing by Anti-Static Bag</p>	5	 <p>Outer box Carton A</p>
3	 <p>3 reels per inner box Box A</p>	6	

Package	Reel		Box				Carton			
	Size	Units	Item	Size(cm)	Reels	Units	Item	Size(cm)	Boxes	Unit
WL-CSP 1.4x2.3	7"	3,000	Box A	18.3*18.3*8.0	3	9,000	Carton A	38.3*27.2*38.3	12	108,000
			Box E	18.6*18.6*3.5	1	3,000	For Combined or Partial Reel.			

Packing Material Anti-ESD Property

Surface Resistance	Aluminum Bag	Reel	Cover tape	Carrier tape	Tube	Protection Band
Ω/cm^2	10^4 to 10^{11}	10^4 to 10^{11}	10^4 to 10^{11}	10^4 to 10^{11}	10^4 to 10^{11}	10^4 to 10^{11}

Richtek Technology Corporation

14F, No. 8, Tai Yuen 1st Street, Chupei City
 Hsinchu, Taiwan, R.O.C.
 Tel: (8863)5526789

RICHTEK

Richtek products are sold by description only. Richtek reserves the right to change the circuitry and/or specifications without notice at any time. Customers should obtain the latest relevant information and data sheets before placing orders and should verify that such information is current and complete. Richtek cannot assume responsibility for use of any circuitry other than circuitry entirely embodied in a Richtek product. Information furnished by Richtek is believed to be accurate and reliable. However, no responsibility is assumed by Richtek or its subsidiaries for its use; nor for any infringements of patents or other rights of third parties which may result from its use. No license is granted by implication or otherwise under any patent or patent rights of Richtek or its subsidiaries.

Copyright © 2023 Richtek Technology Corporation. All rights reserved. **RICHTEK** is a registered trademark of Richtek Technology Corporation.

Datasheet Revision History

Version	Date	Description	Item
02	2023/7/7	Modify	Ordering Information on P2 Electrical Characteristics on P5 Note 3 on P9 Application Information on P16 Packing Information on P29, 30, 31