

REVISIONS					
REV	ECO	DESCRIPTION	DATE	BY	APPR
A1	-	RELEASED DRAWING	May-19-21	Flan	Tommy

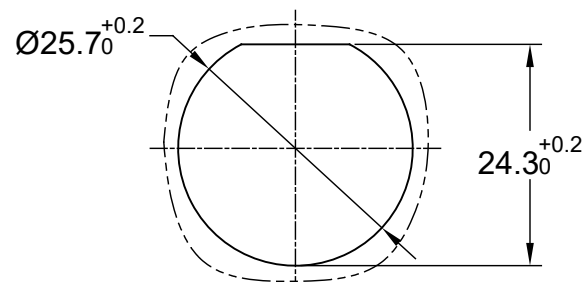
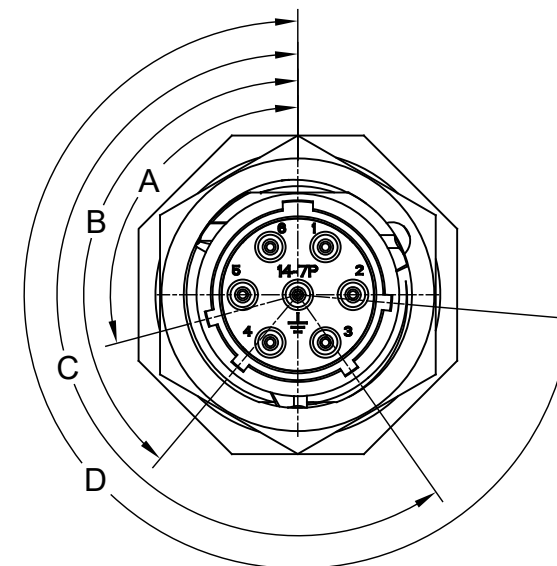
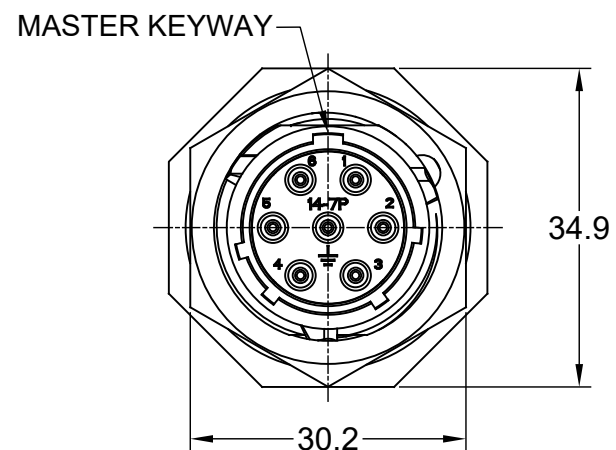
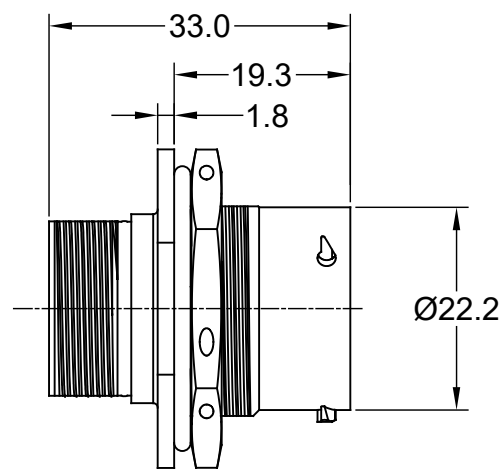

PANEL CUT OUT REFERENCE

NOTES: (UNLESS OTHERWISE SPECIFIED)

- MATERIAL:
 - SHELL: ZINC ALLOY, NICKEL PLATED.
 - INSERT: THERMOPLASTIC, UL94 V-0.
 - NUTS: AL ALLOY NICKEL PLATED.
 - SEAL GASKET: NBR/SILICONE RUBBER.
 - O-RING: NBR/SILICONE RUBBER.
- SPECIFICATIONS:
 - 2.1 RATED CURRENT: 13A (MAX).
 - 2.2 RATED VOLTAGE: 500V(AC/DC).
 - 2.3 OPERATING TEMPERATURE: SEE CHART.
 - 2.4 DIELECTRIC WITHSTANDING VOLTAGE: LESS THAN 2 MILLIAMPS CURRENT LEAKAGE@2000 VOLTS AC.
 - 2.5 INSULATION RESISTANCE: 5000 MEGOHMS MIN.
 - 2.6 IP--CLASS: IP67 (MATED CONNECTOR).
 - 2.7 MATING CYCLES DURABILITY: 500 CYCLES MIN.
 - 2.8 RoHS COMPLIANT.
- SUITABLE CONTACTS: 16# CONTACTS.
- ALL DIMENSIONS ARE FOR REFERENCE USE ONLY.

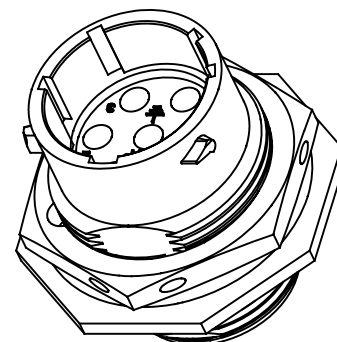

KEY POS	PART NUMBER		A	B	C	D
	-40°C ~ 105°C	-40°C ~ 125°C				
N	RT07147PNH	RT07147PNH03	105°	140°	215°	265°
W	RT07147PWH	RT07147PWH03	60°	140°	215°	265°
X	RT07147PXH	RT07147PXH03	105°	160°	215°	265°
Y	RT07147PYH	RT07147PYH03	105°	140°	225°	265°
Z	RT07147PZH	RT07147PZH03	105°	140°	215°	295°

QUANTITY	PART NUMBER	DESCRIPTION	ITEM
MATERIALS LIST			
UNLESS OTHERWISE SPECIFIED		SIGNATURES DATE	
1) All dimensions are in metric(mm).		DRAWN: Flan	May-19-21
2) Tolerances are as follows:		CHECKED: Blink	May-20-21
1 PL DEC ±0.30		ENGINEER:	
2 PL DEC ±0.15		APPROVAL: Tommy	May-20-21
3 PL DEC ±0.08		CUSTOMER:	
3) Note reference =		THIS DRAWING IS SUPPLIED FOR INFORMATION ONLY. DESIGN FEATURES, SPECIFICATIONS AND PERFORMANCE DATA SHOWN HEREON ARE THE PROPERTY OF THE AMPHENOL CORPORATION. NO RIGHTS OF REPRODUCTION ARE IMPLIED. ALL DIMENSIONS ARE SUBJECT TO NORMAL MANUFACTURING VARIATIONS.	
MATERIAL SPECIFICATIONS:		SIZE TYPE DWG NO. REVISION	
PROCESS SPECIFICATIONS:		B C- RT07147P*Hx A1	
NEXT ASSY:		SCALE: NONE SHEET 1 OF 1	

TITLE: Ecomate RM RECEPTACLE, JAM NUT, SIZE 14,7 POS, PIN
 DWG NO: RT07147P*Hx
 REV: A1
 SH: 1
 OF: 1

Amphenol

Sine Systems - www.amphenol-sine.com
 44724 Morley Drive
 Clinton Township, MI 48036

ECOMATE RM, RECEPTACLE,
 JAM NUT, SIZE 14,7 POS, PIN.