

| DATE | REV | ECN | APP'D. BY |
|----------|-----|-------|-----------|
| 03-09-04 | A1 | 3651 | JMB |
| 1-19-06 | A2 | 7441 | JM |
| 2-8-11 | A3 | 9125 | SMN |
| 5-23-12 | A4 | 9475 | SMN |
| 1-7-15 | A5 | 10172 | TRM |

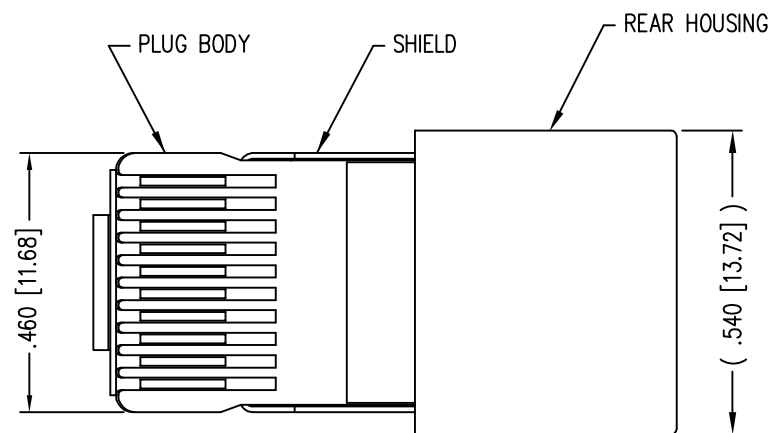

(SHOWN ASSEMBLED)

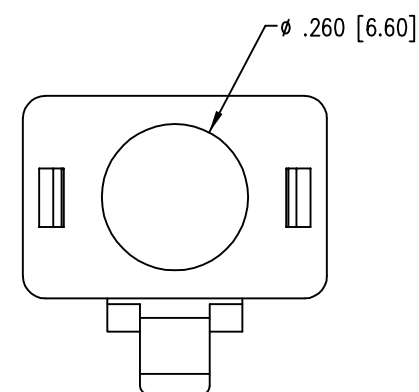
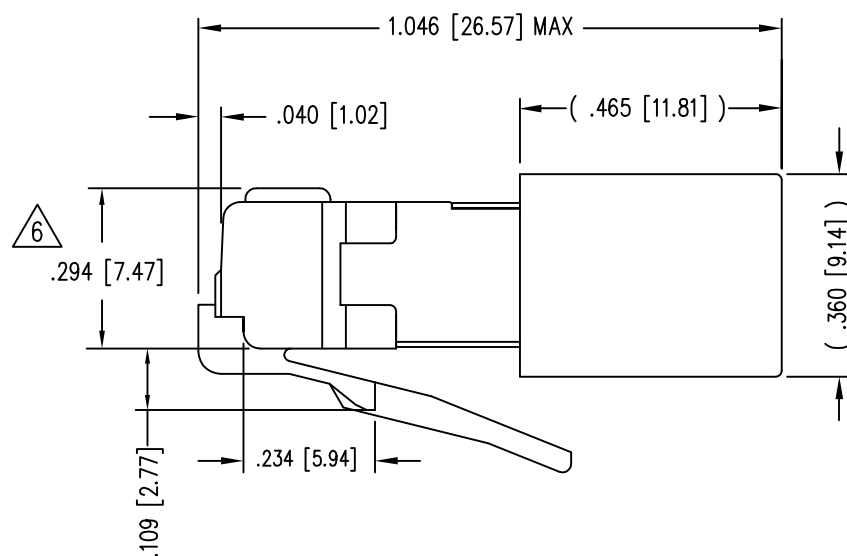
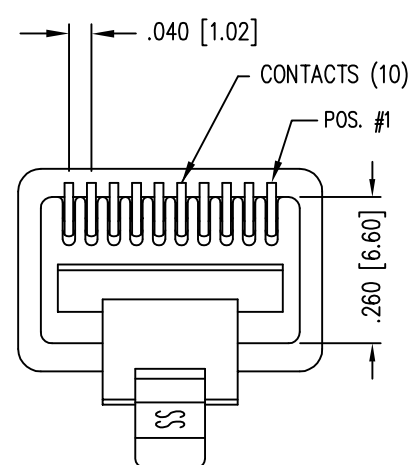

NOTES:

- 1- PLUG KIT CONSISTS OF :
PRE-INSERTED PLUG HOUSING & SHIELD
MANAGEMENT BAR
FERRULE
- 2- MATERIALS :
FRONT HOUSING PLASTIC : CLEAR POLYCARBONATE, UL 94-V0
MANAGEMENT BAR : CLEAR POLYCARBONATE, UL 94-V0
SHIELD : TIN PLATED BRASS
CONTACTS : PHOSPHOR BRONZE, SELECTIVE GOLD PLATING
FERRULE : NICKEL OR TIN PLATED BRASS
- 3- CONTACTS TERMINATE STRANDED CONDUCTORS UP TO .037 [0.94] OUTSIDE DIAMETER OF INSULATION.
- 4- FOR PLUG SPECIFICATION SEE PR026-01.
- 5- DIMENSIONS & TOLERANCES COMPLY WITH TIA-1096 STANDARDS
⚠ TERMINATED PLUG HEIGHT: .237 [6.02] ±.005 [0.13] ON CABLE

| | | |
|---------|--------------------------------|--------------------|
| BULK | 50 MICRO-INCHES [1.27um] | 940-SP-361010-A161 |
| PACKAGE | CONTACT PLATING IN MATING AREA | PART NUMBER |

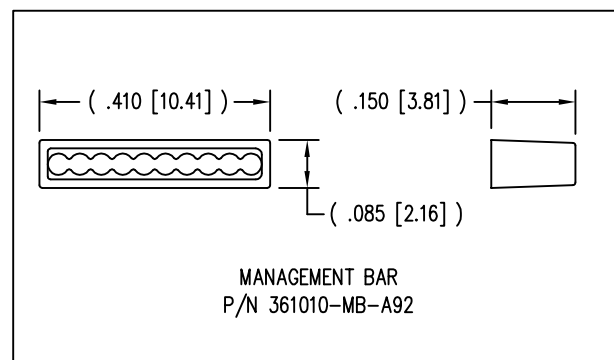
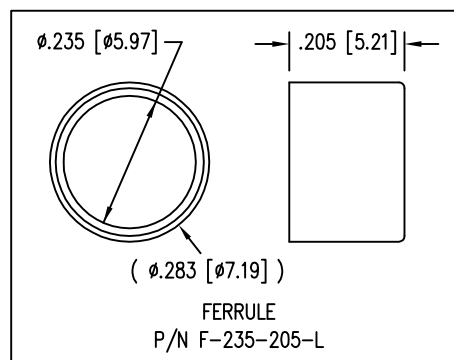

THIRD ANGLE PROJECTION

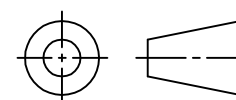

1118 Susquehanna Trail South
Glen Rock, PA 17327-9199
(717) 235-7512
<http://www.stewartconnector.com>

DO NOT SCALE DRAWING
DRAWING IS SUBJECT TO CHANGE WITHOUT NOTICE

TITLE: 10 X 10 SHIELDED PLUG

DIMENSIONS: INCHES [METRIC]
UNLESS OTHERWISE SPECIFIED TOLERANCES ARE ±.005 [0.13] ANGLES ARE ± 1°

THIS DRAWING AND THE SUBJECT MATTER SHOWN THEREON ARE CONFIDENTIAL AND THE PROPRIETARY PROPERTY OF STEWART CONNECTOR AND SHALL NOT BE REPRODUCED, COPIED, OR USED IN ANY MANNER WITHOUT PRIOR WRITTEN CONSENT OF STEWART CONNECTOR. THIS PRODUCT MAY BE PROTECTED BY ONE OR MORE OF THE FOLLOWING US PATENTS:
5628647 6402558 6409535 6524128
7753717 8033863
OTHER PATENTS MAY BE PENDING.

| | |
|------------------|--------------|
| DRN BY: RS | DATE 8-16-95 |
| APPD BY: JW | DATE 8-16-95 |
| DWG NO. CT310107 | REV. A5 |

SHEET NO. 1 OF 1

