

SLX040A0XY3-SRZ Non-Isolated DC-DC Power Module

7.0V_{DC} - 14V_{DC} input; 0.45V_{DC} to 2.0V_{DC} output; 40A Output Current

RoHS Compliant

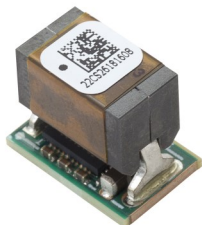

The SLX040A0XY3 Digital DLynxIII™ Satellite power module is a non-isolated dc-dc converter that can deliver up to 40A of output current. It operates over a wide input voltage range from 7.0V_{DC} to 14V_{DC} and provides precisely regulated output voltage programmable from 0.45V_{DC} to 2.0V_{DC} via PMBus™ set through the master module. The master module employs an advanced PID based adjustable digital control loop which ensures loop stability, provides fast transient response and reduces amount of required output capacitance. Additional 40A satellite phase modules can be connected in parallel to form a high current common rail or a second stand-alone bus with the right Master Module. Main features include: digital PMBus™ interface, programmable enable logic and control, cycle-by-cycle output current monitoring, input and output under-voltage and over-voltage protections, under-temperature and over-temperature protections and more. The SLX040A0XY3 power module is highly configurable, and yet easy to use. See table at end of this datasheet for possible Master-Satellite pairings

Applications

- High performance ASIC with dual power rails
- Networking processor power (Broadcom, Cavium, Marvell, NXP)
- High current FPGA power (Xilinx, Intel)
- High performance ARM processor power
- Telecommunications and networking equipment
- Servers and storage applications
- Test and Measurement equipment
- Industrial equipment

Features

- Compliant to RoHS II EU Directive 2011/65/EC and amended Directive (EU) 2015/863
- Compliant to IPC-9592 (Sept. 2008), Category 2, Class TBD
- Compliant to REACH Directive (EC) No 1907/2006
- Compatible with a Pb-free or SnPn reflow soldering process
- Wide Input voltage range: 7.0V_{DC}-14V_{DC}
- Output voltage programable from 0.45V_{DC} to 2.0V via PMBus™
- Delivers up to 40 A_{DC} output current
- Supports Voltage Rails requiring 3% tolerance
- Operation of up to 3 Satellite phases in parallel(120A) as a common or as a 40A separate bus.
- PID control and multi-phase operation provides fast transient response, reduced output capacitance, and stability¹.
- Tightly regulated output voltage¹.
- Low output ripple and noise¹
- Fixed switching frequency¹
- Small size: 12.9 mm x 8.48 mm x 11.05 mm
0.507 in x 0.335 in x 0.435 in
- Digital interface compliant to PMBus™ Rev.1.3 protocol¹
- Programmable enable logic with On/Off Control¹.
- Protections: OVP, UVP, OCP, OTP¹
- Cycle-by-cycle output current monitoring and protection¹
- Over temperature protection¹
- Wide operating temperature range -40°C to 85°C
- Excellent Thermal Performance – Module delivers full output @12V_{IN}, 1V_{OUT}, 70°C ambient and 200 LFM (1m/s) airflow¹
- When paralleled, Satellite modules are interleaved to reduce input and output ripple.¹
- UL* 62368-1, 2nd Ed. Recognized, and pending DIN VDE 0868-1/A11:2017 (EN62368-1:2014/A11:2017)
- ISO** 9001 and ISO14001 certified manufacturing facilities

¹ Needs Master module for this feature

* UL is a registered trademark of Underwriters Laboratories, Inc.

† CSA is a registered trademark of Canadian Standards Association.

‡ VDE is a trademark of Verband Deutscher Elektrotechniker e.V.

** ISO is a registered trademark of the International Organization of Standards.

The PMBus name and logo are registered trademarks of the System Management Interface Forum (SMIF).

Technical Specifications

Note:

Only PowerStage related data has been provided in the document. For controller related data like voltage setpoints, accuracy, etc. refer to the Master unit being associated with this Satellite unit. Table towards end of this datasheet shows possible master pairings for this Satellite unit.

Absolute Maximum Ratings

Stresses in excess of the absolute maximum ratings can cause permanent damage to the device. These are absolute stress ratings only. Operational functionality of the device is not implied at these or any other conditions in the excess of those given in the operations sections of the data sheet. Exposure to the absolute maximum ratings for extended periods may adversely affect the device reliability.

Parameter	Symbol	Min	Max	Unit
Input Voltage (continuous)	V_{IN}	-0.3	14.5	V
Operating Ambient Temperature	T_A	-40*	85	°C
Storage Temperature		-55	125	°C

* At -40°C and 7V_{in}, module may experience a few hiccup cycles before starting into full load

CAUTION: This power module is not internally fused. An input line fuse must always be used.

This power module can be used in a wide variety of applications, ranging from simple standalone operation to an integrated part of sophisticated power architecture. To preserve maximum flexibility, internal fusing is not included, however, to achieve maximum safety and system protection, always use an input line fuse. The safety agencies require a fast-acting fuse with a maximum rating of 30A, 100V (see Safety Considerations section). Based on the information provided in this Data Sheet on inrush energy and maximum dc input current, the same type of fuse with a lower rating can be used. Refer to the fuse manufacturer's Data Sheet for further information.

Recommended Operating Conditions

Parameter	Symbol	Min	Max	Unit
IMON_SATx, TSENx, PWM_SATx,		0	4	V

Electrical Specifications

Unless otherwise indicated, specifications apply for all operating input voltages, resistive load and temperature conditions.

Parameter	Condition	Symbol	Min	Typ	Max	Unit
Operating Input Voltage	All	V_{IN}	7.0		14	V _{DC}
Maximum Input Current ($V_{IN}=7.0V$ to 14V, $I_O=I_{O,max}$)	All	$I_{IN,max}$		12.2		A _{DC}
Input No Load Current ($V_{IN} = 12V_{DC}$, $I_O = 0$, module enabled)	$V_{O,set} = 0.45V_{DC}$	$I_{IN,No\ load}$		208		mA
	$V_{O,set} = 2.0V_{DC}$	$I_{IN,No\ load}$		318		mA
Input Stand-by Current ($V_{IN} = 12V_{DC}$, module disabled)	All	$I_{IN,stand-by}$		32		mA
Inrush Transient	All	I^2t		1.35		A ² s
Input Reflected Ripple Current, peak-to-peak (5Hz to 20MHz, 1μH source impedance; $V_{IN} = 7.0$ to 14V, See Test Configurations)	All			85		mA _{p-p}
Input Ripple Rejection (120Hz)	All			-55.79		dB

Technical Specifications (continued)

Electrical Specifications (continued)

Parameter	Condition	Symbol	Min	Typ	Max	Unit
Input Ripple ($V_{IN}=V_{IN, nom}$ and $I_O=I_{O, min}$ to $I_{O, max}$ and $T_a=25^\circ\text{C}$ $C_{in} = 8 \times 1 \mu\text{F} \parallel 16 \times 10 \mu\text{F} \parallel 16 \times 22 \mu\text{F} \parallel 4 \times 560 \mu\text{F}$)				57@0.45 V_o		mV_{pk-pk}
Peak-to-Peak (5Hz to 20MHz bandwidth)	All			97@2 V_o		mV_{pk-pk}
Output Ripple at Nominal Output ($V_{IN}=V_{IN, nom}$ and $I_O=I_{O, min}$ to $I_{O, max}$ and $T_a=25^\circ\text{C}$ $C_o = 4 \times 0.1 \mu\text{F} \parallel 4 \times 0.047 \mu\text{F} \parallel 15 \times 22 \mu\text{F} \parallel 73 \times 47 \mu\text{F} \parallel 6 \times 470 \mu\text{F}$)				1.9@0.45 V_o		mV_{pk-pk}
Peak-to-Peak (5Hz to 20MHz bandwidth)	All			3.2@2 V_o		mV_{pk-pk}
RMS (5Hz to 20MHz bandwidth)	All			0.8mV		mV_{rms}
Output Current (in source mode)	All	I_o		40		A_{DC}
Efficiency $V_{IN} = 12V_{DC}$, $T_A = 25^\circ\text{C}$ $I_O = I_{O, max}$, $V_O = V_{O, set}$	$V_{O, set} = 0.45V_{DC}$	η		81.4		%
	$V_{O, set} = 1.0V_{DC}$			90.4		%
	$V_{O, set} = 1.5V_{DC}$			92.8		%
	$V_{O, set} = 2.0V_{DC}$			94.1		%
Switching Frequency (Fixed)	All	f_{sw}		580		kHz

Feature Specifications (continued)

Parameter	Condition	Symbol	Min	Typ	Max	Unit
Over Temperature Protection (See Thermal Considerations section, setting in Master)	All	T_{OT}		125		$^\circ\text{C}$
PMBus Over Temperature Warning Threshold *	All	T_{WARN}		110		$^\circ\text{C}$
Input Undervoltage Lockout						
Turn-on Threshold	All			6.25		V_{DC}
Turn-off Threshold	All			5.75		V_{DC}
Hysteresis	All			0.5		V_{DC}

* Over temperature Warning – Warning may not activate before alarm and unit may shutdown before warning.

General Specifications

Parameter	Device	Min	Typ	Max	Unit
Calculated MTBF ($I_O=0.8I_{O, max}$, $T_A=40^\circ\text{C}$) Telecordia Issue 4 Method 1 Case 3	All		82,237,057		Hours
Weight			3.025 (0.107)		g (oz.)

Technical Specifications (continued)

Characteristic Curves

The following figures provide typical characteristics for the 40A Satellite DlynXIII™ module at 0.45Vo and 25°C.

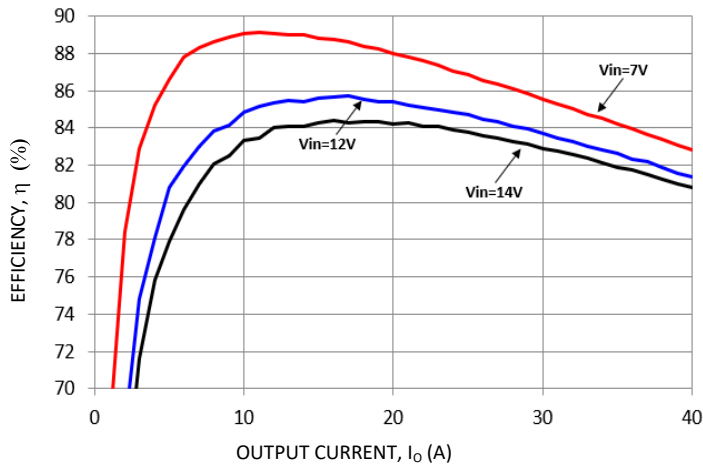

Figure 1. Converter Efficiency versus Output Current.

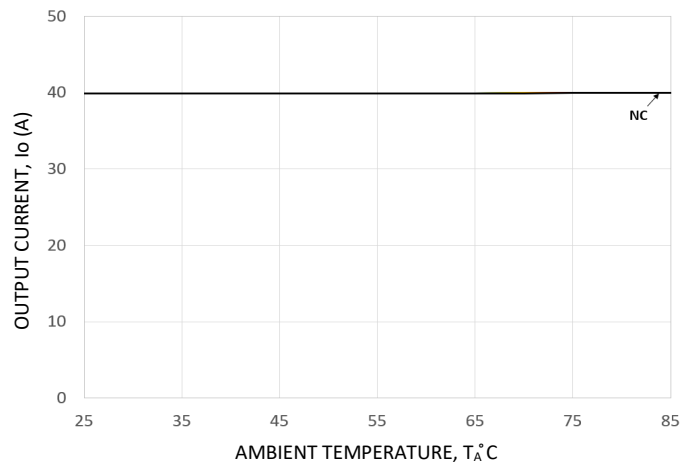

Figure 2. Derating Output Current versus Ambient Temperature and Airflow.

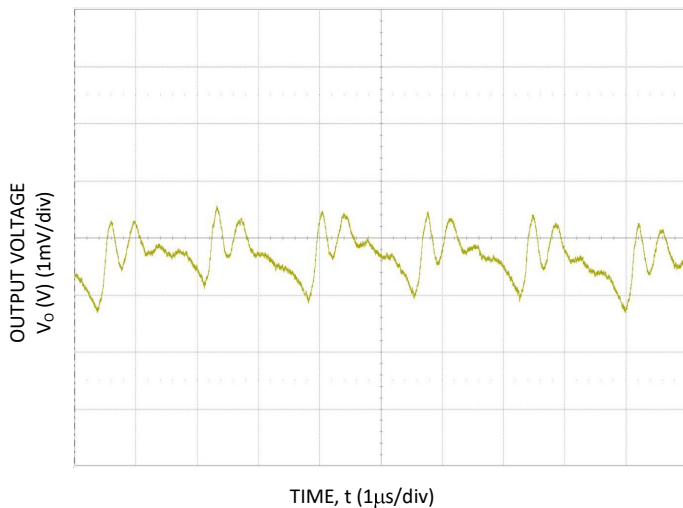

Figure 3. Typical output ripple ($C_o=4 \times 0.047\mu\text{F} + 4 \times 0.1\mu\text{F} + 15 \times 22\mu\text{F} + 73 \times 47\mu\text{F} + 6 \times 470\mu\text{F}$ polymer, $V_{IN} = 12\text{V}$, $I_o = I_{o,max}$).

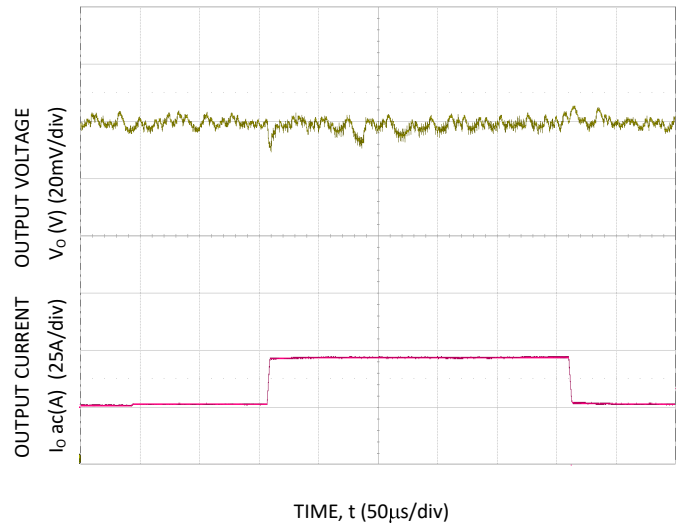

Figure 4. Trans. Resp. to 10A/µs Load Change from 25% to 75% at 12V_{IN}, $C_o=4 \times 0.047\mu\text{F} + 4 \times 0.1\mu\text{F} + 15 \times 22\mu\text{F} + 73 \times 47\mu\text{F} + 6 \times 470\mu\text{F}$ polymer

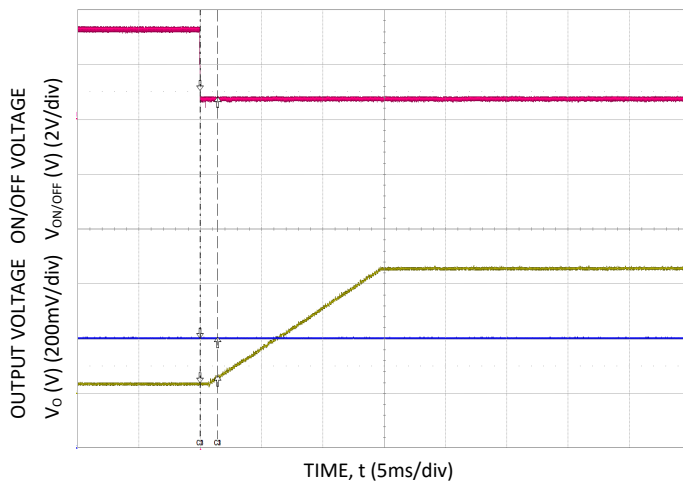

Figure 5. Typical Start-up Using On/Off Voltage ($I_o = I_{o,max}$).

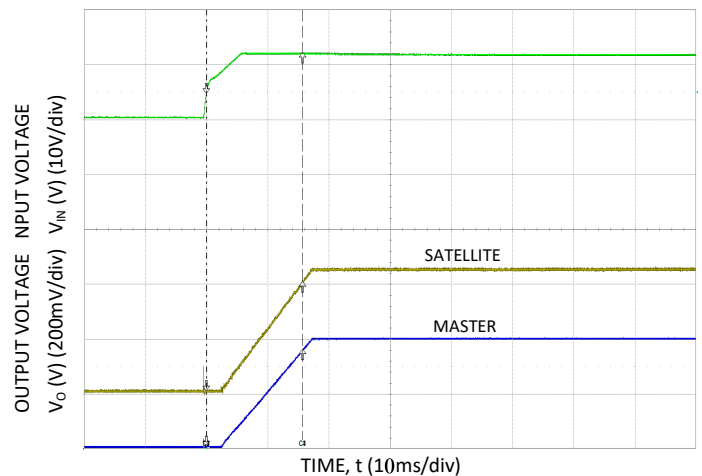

Figure 6. Typical Start-up Using Input Voltage ($V_{IN} = 12\text{V}$, $I_o = I_{o,max}$).

Technical Specifications (continued)

Characteristic Curves

The following figures provide typical characteristics for the 40A Master DlynxIII™ module at 1.0V_o and 25°C.

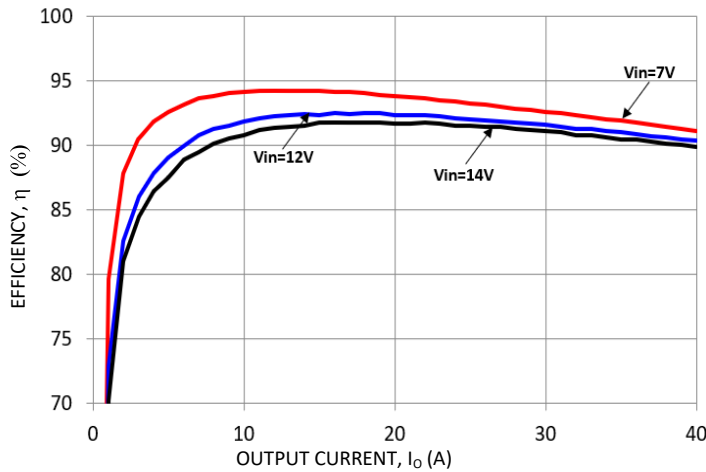

Figure 7. Converter Efficiency versus Output Current.

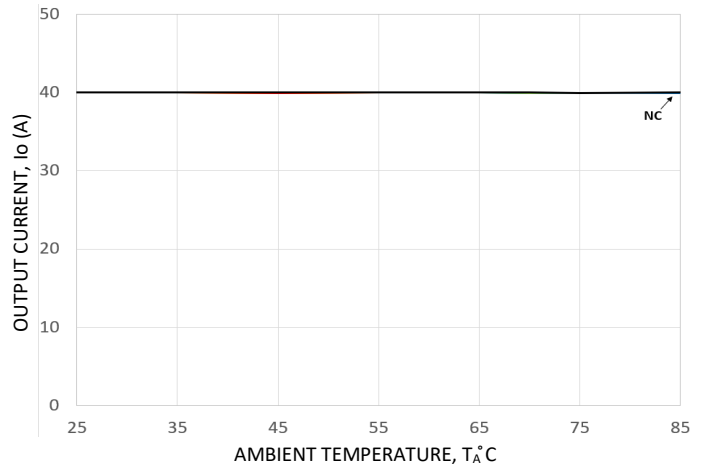

Figure 8. Derating Output Current versus Ambient Temperature and Airflow.

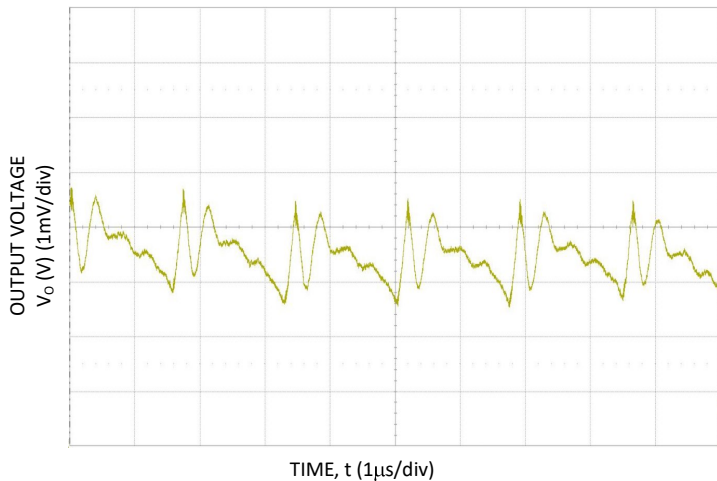

Figure 9. Typical output ripple (C_o=4x0.047µF + 4x0.1µF + 15x22µF + 73x47µF + 6x470µF polymer, V_{IN} = 12V, I_o = I_{o,max}).

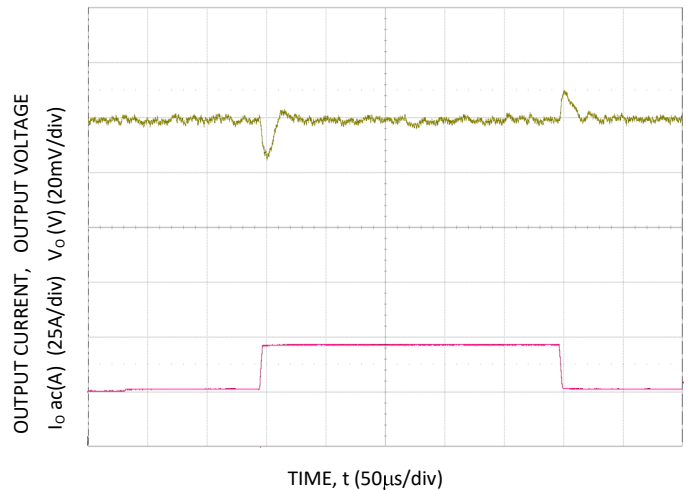

Figure 10. Trans. Resp. to 10A/µs Load Change from 25% to 75% at 12V_{IN}, Co= 4x0.047µF + 4x0.1µF + 15x22µF + 73x47µF + 6x470µF polymer

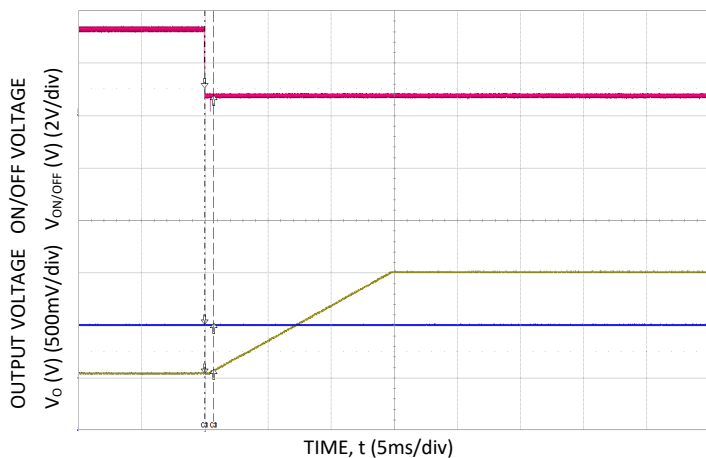

Figure 11. Typical Start-up Using On/Off Voltage (I_o = I_{o,max}).

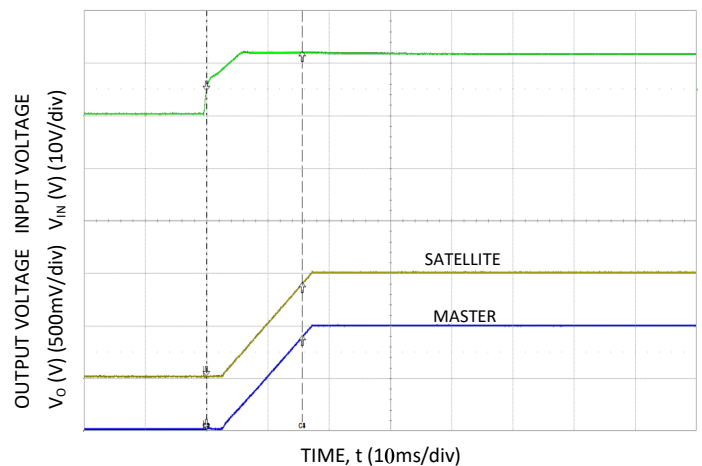

Figure 12. Typical Start-up Using Input Voltage (V_{IN} = 12V, I_o = I_{o,max}).

Technical Specifications (continued)

Characteristic Curves

The following figures provide typical characteristics for the 40A Master DlynxIII™ module at $1.5V_o$ and 25°C .

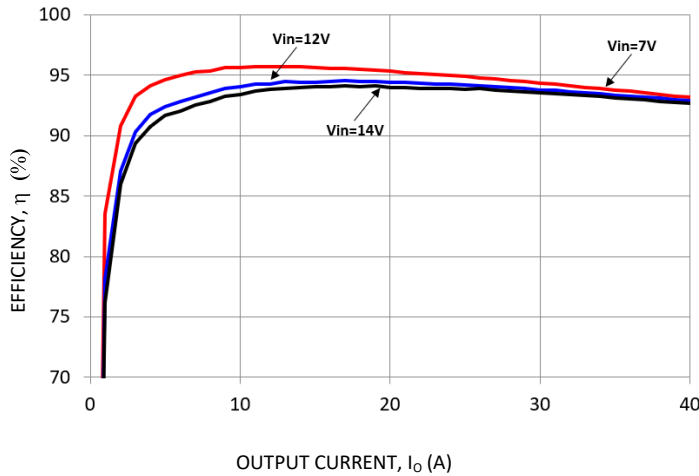

Figure 13. Converter Efficiency versus Output Current.

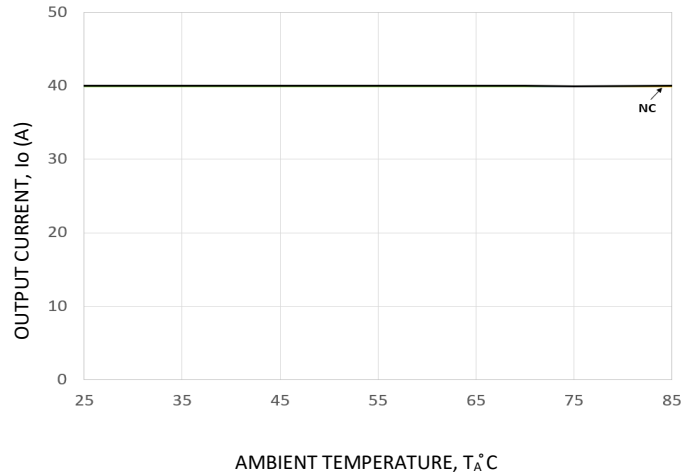

Figure 14. Derating Output Current versus Ambient Temperature and Airflow.

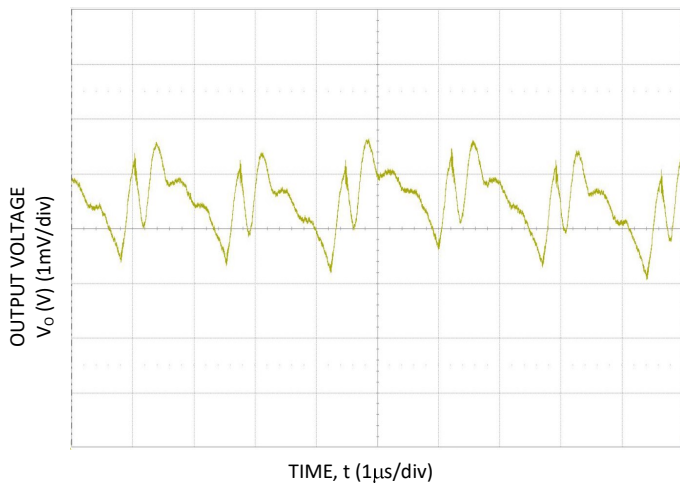

Figure 15. Typical output ripple ($C_o=4 \times 0.047\mu\text{F} + 4 \times 0.1\mu\text{F} + 15 \times 22\mu\text{F} + 73 \times 47\mu\text{F} + 6 \times 470\mu\text{F}$ polymer, $V_{IN} = 12\text{V}$, $I_o = I_{o,max}$).

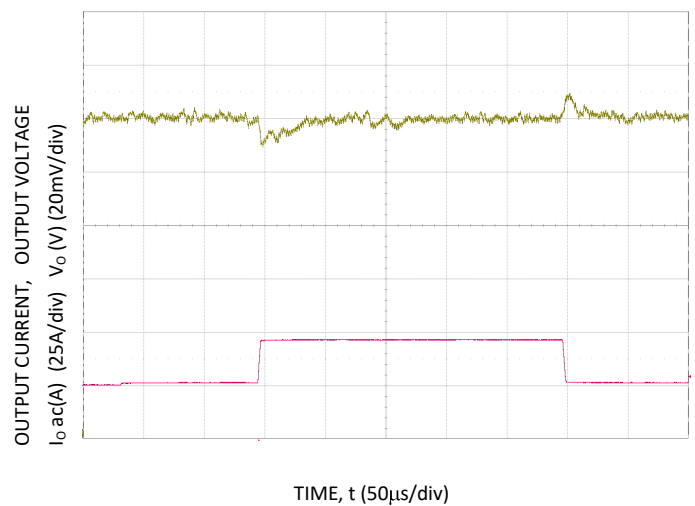

Figure 16. Trans. Resp. to $10\text{A}/\mu\text{s}$ Load Change from 25% to 75% at 12V_{IN} , $C_o=4 \times 0.047\mu\text{F} + 4 \times 0.1\mu\text{F} + 15 \times 22\mu\text{F} + 73 \times 47\mu\text{F} + 6 \times 470\mu\text{F}$ polymer

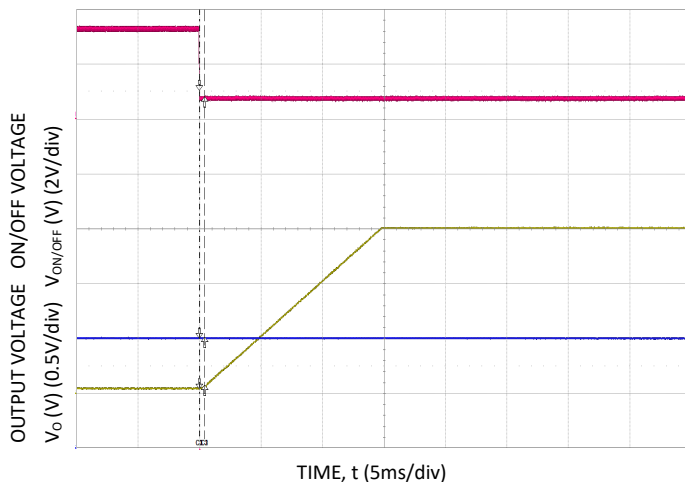

Figure 17. Typical Start-up Using On/Off Voltage ($I_o = I_{o,max}$).

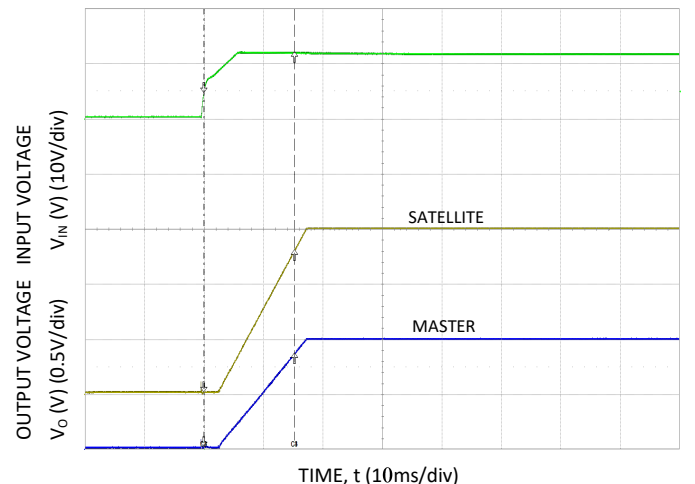

Figure 18. Typical Start-up Using Input Voltage ($V_{IN} = 12\text{V}$, $I_o = I_{o,max}$).

Technical Specifications (continued)

Characteristic Curves

The following figures provide typical characteristics for the 40A Master DlynxIII™ module at 2V_o and 25°C.

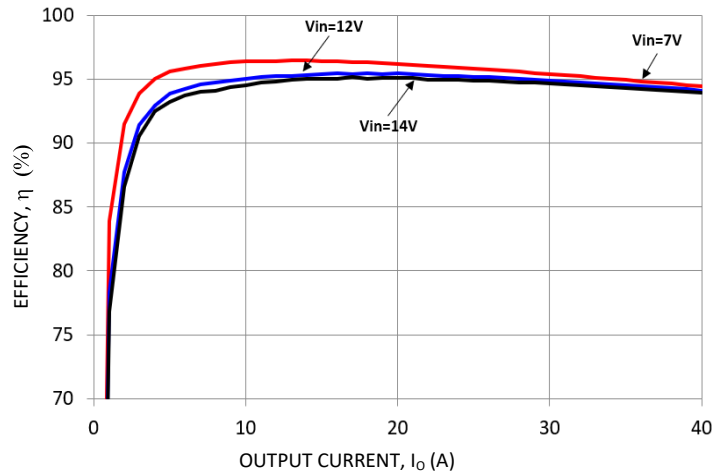

Figure 19. Converter Efficiency versus Output Current.

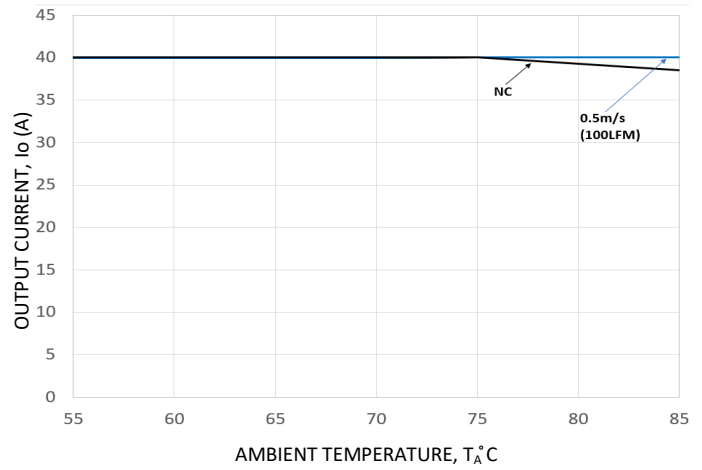

Figure 20. Derating Output Current versus Ambient Temperature and Airflow.

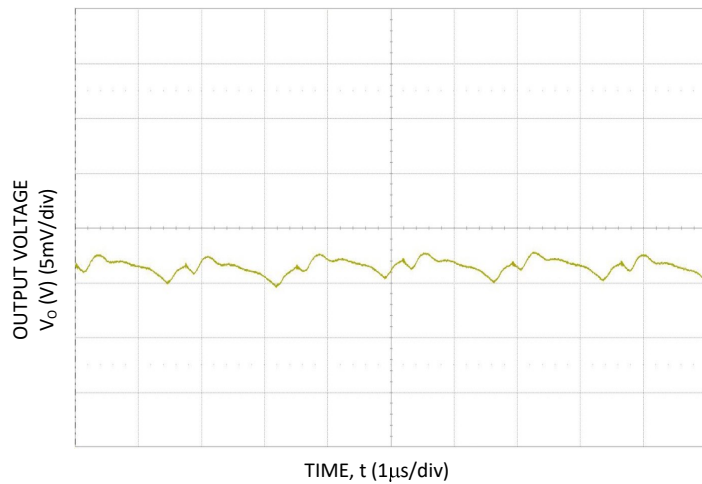

Figure 21. Typical output ripple ($C_o=4 \times 0.047\mu\text{F} + 4 \times 0.1\mu\text{F} + 15 \times 22\mu\text{F} + 73 \times 47\mu\text{F} + 6 \times 470\mu\text{F}$ polymer, $V_{IN} = 12\text{V}$, $I_o = I_{o,max}$)

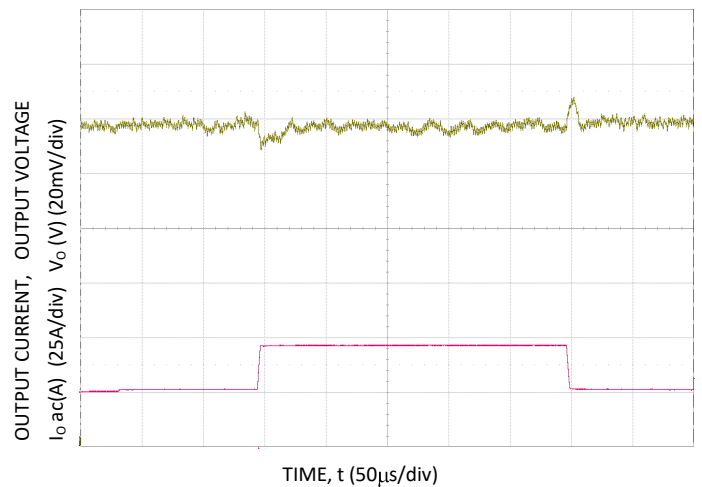

Figure 22. Trans. Resp. to 10A/µs Load Change from 25% to 75% at 12V_{IN}, $C_o = 4 \times 0.047\mu\text{F} + 4 \times 0.1\mu\text{F} + 15 \times 22\mu\text{F} + 73 \times 47\mu\text{F} + 6 \times 470\mu\text{F}$ polymer

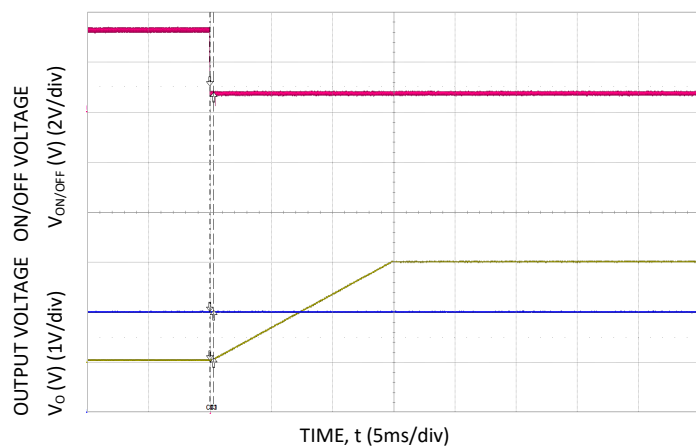

Figure 23. Typical Start-up Using On/Off Voltage ($I_o = I_{o,max}$).

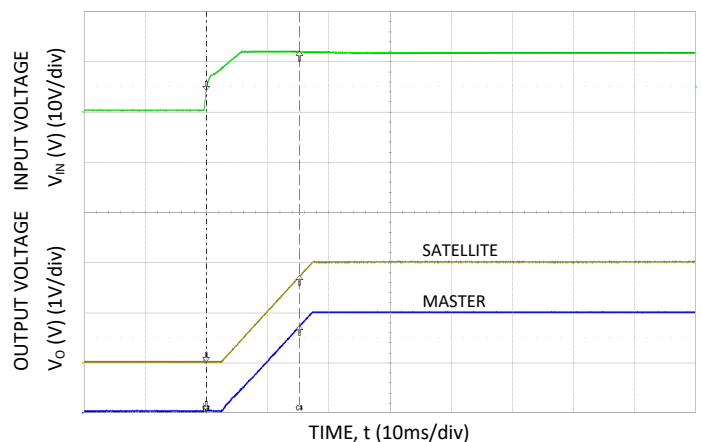

Figure 24. Typical Start-up Using Input Voltage ($V_{IN} = 12\text{V}$, $I_o = I_{o,max}$).

Technical Specifications (continued)

Design Considerations

Input Filtering

To minimize input voltage ripple, ceramic capacitors are recommended at the input of the module. Figure 25 shows the input ripple voltage for various output voltages at 100% of load current with different input capacitor combinations to achieve 1.5 % and lower input ripple. Since voltage used was $12V_{IN}$, all the curves stayed below the 180mV(1.5%) threshold.

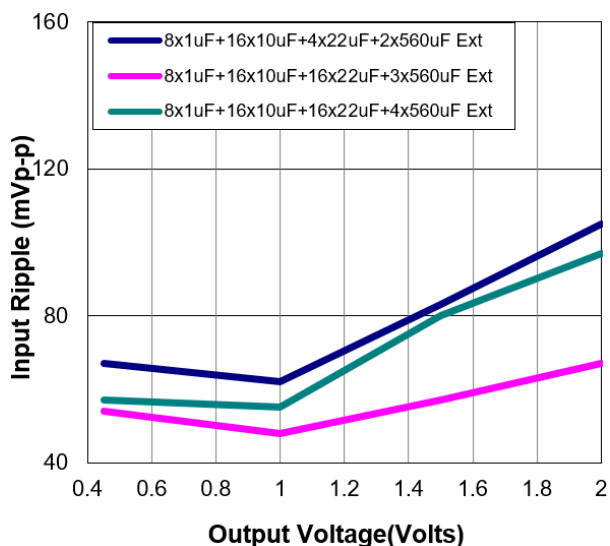

Figure 25. Input ripple voltage for various output voltages with three input capacitor combinations at full load. Input voltage is 12V.

These caps were placed at the bottom of the board and directly under each of the phases as shown in the layout of the evaluation board Fig. 31). Each phase had a minimum of 2x1uF and 3x10uF closest to the pins.

Output Filtering

These modules are designed for low output ripple voltage and will meet stringent output ripple.

Figure 26 provides output ripple information various output voltages and full load current for different levels of capacitance. Ceramic capacitance will reduce output ripple and improve the transient performance of the module.

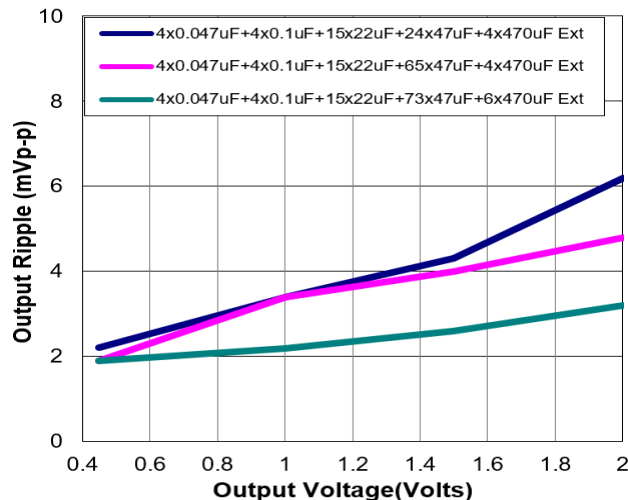

Figure 26. Peak to peak output ripple voltage for various output voltages with external capacitors at the output (40A load). Input voltage is 12V.

Transient Testing

Module performance for different transient conditions at rated output capacitance.

$$^1K_p=44, K_i=22, K_d=56, K_{pole1}=5, K_{pole2}=7$$

Voltage Rail (volts)	Step Load (% of full load)	Load Slew Rate (A/μsec)	ΔV Variation (%)
0.45V ¹	50	10	-2.37% to 1.2%
1V*	50	10	-1.56% to 0.98%
1.5V*	50	10	-0.7% to 0.62%
2V ⁺	50	10	-0.575% to 0.4%

$$*K_p=36, K_i=22, K_d=56, K_{pole1}=3, K_{pole2}=5$$

$$^+K_p=36, K_i=22, K_d=55, K_{pole1}=3, K_{pole2}=5$$

Technical Specifications (continued)

Safety Considerations

For safety agency approval, the power module must be installed in compliance with the spacing and separation requirements of the end-use safety agency standards, i.e., UL ANSI/UL* 62368-1 and **pending** DIN VDE 0868-1/A11:2017 (EN62368-1:2014/A11:2017)

For the converter output to be considered meeting the requirements of safety extra-low voltage (SELV) or ES1, the input must meet SELV/ES1 requirements. The power module has extra low voltage (ELV) outputs when all inputs are ELV.

The SLX040A0X model was tested using an external Littelfuse 456 series fast-acting fuse rated at 30A, 100Vdc in the ungrounded input. The maximum hot spot temperature, measured on IC100/C102 shall not exceed 120/115°C

Remote On/Off

The SLX040 module can be turned ON and OFF either by using the ON/OFF pin (Analog interface) or through the PMBus interface (Digital). The module can be configured in a number of ways through the PMBus interface to react to the ON/OFF input:

- Module ON/OFF can be controlled only through the analog interface (digital interface ON/OFF commands are ignored) in connected Master Module
- Module ON/OFF can be controlled only through the PMBus interface (analog interface is ignored) in connected Master Module
- Module ON/OFF can be controlled by either the analog or digital interface in connected Master Module

The default state of the module (as shipped from the factory) is to be controlled by the PMBus interface and analog interface. If the module is to be controlled only through the digital interface, this change must be made through the PMBus. These changes can be made and written to non-volatile memory on the module so that it is remembered for subsequent use.

The ON/OFF pin in master module should not be left floating and must be pulled either high or low .

Digital On/Off

Please see the Digital Feature Descriptions section.

Monotonic Start-up and Shutdown

The module has monotonic start-up and shutdown behavior on the output for any combination of rated input voltage, output current, and operating temperature range.

Startup into Pre-biased Output

The module will start into a pre biased output on output as long as the pre bias voltage is 15% less than the set output voltage.

Remote Sense

The Master module has a differential Remote Sense feature to minimize the effects of distribution losses by regulating the voltage between the sense pins (VS+ and VS-) for the output. The voltage drop between the sense pins and the VOUT and GND pins of the module should not exceed 100mV.

Technical Specifications (continued)

Overcurrent Protection (OCP) - through Master

To provide protection in a fault (output overload) condition, the unit is equipped with internal current limiting circuitry on the output and can endure current limiting continuously. The module's overcurrent response is to hiccup forever. OCP response can be changed with a PMBus command.

Overtemperature Protection—through Master

To provide protection in a fault condition, the unit has a thermal shutdown circuit. The unit will shut down if the overtemperature threshold of 125°C (typ) is exceeded at the thermal reference point Tref. Once the unit goes into thermal shutdown, it will wait to cool down to 97% of set limit before attempting to restart.

Power Good—through Master

Power good needs external pull up resistor. The Pins are called VRRDY1 and VRRDY2 (loop1/loop2) and their thresholds are specified via PMBus.

An example of Power Good / VRRDY behavior is shown below. The top green waveform is the slowly rising input voltage and the bottom brown waveform is the output voltage. As soon as the output voltage crosses the VRRDY1 threshold, the pin is pulled high as seen in the scope capture.

Figure 27. V_{IN}, VRRDY1 and Vout1 waveform.

Start-up procedure—through Master

ON/OFF

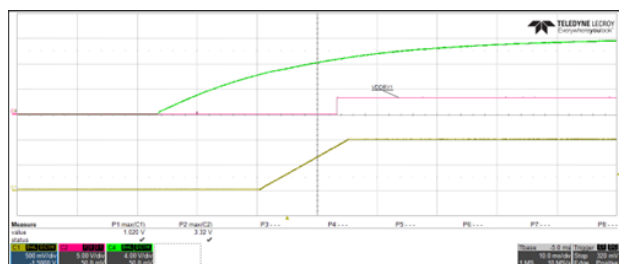

The SLX040A0XY3-SRZ is a programmable ON/OFF logic power module. The default state of the module is Negative Logic. The module is ON when the ON/OFF pin is at “logic low” state, and OFF when it is at “logic high” state. Positive ON/OFF logic can be implemented through PMBus control.

The module could be turned ON and OFF from an external enable signal or by the OPERATION [0x01](#) command. Desired behavior is set by ON_OFF_CONFIG [0x02](#) command.

Input overvoltage and undervoltage protections—through Master

The input overvoltage and undervoltage protections prevent the SLX040A0XY3-SRZ from operating when the input is above or falls below preset thresholds.

The customers are strongly advised not to increase the preset input overvoltage limit or decrease input undervoltage limit as it may result in compromising product safety. This is a violation of the module's absolute maximum and minimum ratings which will void the product warranty.

Command details in PMBus App Note.

Output overvoltage and undervoltage protections—through Master

The SLX040A0XY3-SRZ offers an internal output overvoltage protection circuit that can be used to protect sensitive load circuitry from being subjected to a voltage higher than its prescribed limits.

The SLX040A0XY3-SRZ overvoltage and undervoltage behavior can be configured through the following commands:

VOUT_OV_FAULT_RESPONSE [0x41](#),
 VOUT_UV_FAULT_RESPONSE [0x45](#),
 VOUT_OV_FAULT_LIMIT [0x40](#),
 VOUT_OV_WARN_LIMIT [0x42](#),
 VOUT_UV_WARN_LIMIT [0x43](#), and
 VOUT_UV_FAULT_LIMIT [0x44](#).

See commands description for more details.

Output overcurrent protection

Output overcurrent protection prevent excessive forward current through the module and the load during abnormal operation. Overcurrent protection is cycle-by-cycle in nature. This is managed by IOUT_OC_FAULT_LIMIT [0x46](#).

Customers are strongly advised not to increase the preset output overcurrent limits or decrease output undercurrent limits as it may result in compromising product safety. This is a violation of the module's absolute maximum and minimum ratings which will void the product warranty.

Technical Specifications (continued)

The output overcurrent warning limits and fault response is managed by the following commands:

IOUT_OC_WARN_LIMIT [0x4A](#), IOUT_OC_FAULT_RESPONSE [0x47](#).

Overtemperature protection—through Master

The SLX040A0XY3-SRZ overtemperature protection ensures that the temperature inside the module is below all the components' temperature maximum limit.

The overtemperature protections are managed by the following commands: OT_FAULT_RESPONSE [0x50](#), OT_WARN_LIMIT [0x51](#).

Monitoring through SMBAlert or SALERT pin—through Master

The SLX040A0XY3-SRZ can be externally monitored for fault conditions by monitoring the SMBALERT pin (in Master Module), which is asserted when any number of preconfigured fault conditions occur. The module can also be monitored continuously for any number of power conversion parameters. Some of most useful fault monitoring commands are: STATUS_BYTE [0x78](#), STATUS_WORD [0x79](#), STATUS_VOUT [0x7A](#), STATUS_IOUT [0x7B](#), STATUS_INPUT [0x7C](#), STATUS_TEMPERATURE [0x7D](#).

Control loop tuning—through Master

The heart of SLX040A0XY3-SRZ is a fully digital controller IC with state-of-the-art PID Control. By default, this control loop is stable for recommended output capacitance and loads. However, it may be further tuned to achieve higher performance under more specific application requirements. Since the control scheme is digital from end to end, there is no dependence upon external compensation networks. This simplifies the design process by removing such considerations as temperature and process variation of passive components. Control parameters are set through the [0xD0](#) PMBus command.

Layout considerations

The evaluation board layout and schematic files are available for interested users. These can be downloaded through the webpage or by contacting ABB through the web request or helpline.

Technical Specifications (continued)

Digital Compensator—through Master

The SLX040 module uses digital control to regulate the output voltage. As with all POL modules, external capacitors are usually added to the output of the module for two reasons: to reduce output ripple and noise and to reduce output voltage deviations from the steady-state value in the presence of dynamic load current changes.

The SLX040 comes with default compensation values programmed into the non-volatile memory of the module. These digital compensation values can be adjusted externally to optimize transient response and ensure stability for a wide range of external capacitance, and with different types of output capacitance.

Table 1

Output Capacitors	kpole1	Kpole2	P	I	D
15x22uF + 24x47uF + 4x470uF	5	7	36	22	56
15x22uF + 65x47uF + 4x470uF	5	7	36	22	56
15x22uF + 73x47uF + 6x470uF	5	7	36	22	56

Power Module Wizard

Designers can access a free, web-based, easy to use tool that helps users simulate and tune the SLX040A0XY3-SRZ feedback loop parameters. Go to <http://abb.transim.com> and sign up for a free account to use the module selector tool. The tool also offers online Simplis/Simatrix models that can be used to assess transient performance, module stability, etc.

Digital Power Insight (DPI)

DPI is a software tool that helps users evaluate and simulate the PMBus performance of the SLX040A0XY3A modules without the need to write software is also available. The software can be downloaded for free from our webpage. A USB to I²C adapter and associated cable set are required for proper functioning of the software suite. For first time users, we recommend using the DPI Evaluation Kit, which can be purchased from any of the leading distributors. Please ensure that the USB to I²C adapter being used/ purchased is Version 2.2 or higher. Part Numbers are available in the last few pages of this datasheet

Technical Specifications (continued)

PMBus Addressing

This is determined by the PMBus address of the Master Module associated with the SLX040. The Page (0x00) command is used to switch between Master or Satellite or both.

Whether the satellite has to be used in parallel with MLX160 on the same loop or on a different loop with any of the Masters is set through the associated Master Module. Refer to the Master Module Datasheet for more information

Technical Specifications (continued)

Quick Start process—MLX xx0 up with SLX040 on PMBus with external ENABLE

1. Power up module.
2. Configure required output voltage through PAGE **0x00** and VOUT_COMMAND **0x21**, for each output loop as applicable.
3. 3. Configure the following if needed.
 - VOUT_OV_FAULT_RESPONSE **0x41**.
 - VOUT_OV_FAULT_LIMIT **0x40**.
 - VOUT_OV_WARN_LIMIT **0x42**.
4. Current Calibration of SLX040 as described in next section of this datasheet and update the following as per configuration.
 - IOUT_OC_FAULT_LIMIT (0x46).
 - IOUT_OC_FAULT_RESPONSE (0x47).
 - IOUT_OC_WARN_LIMIT (0x4A).
5. If Changes are final and Configuration has to be stored in NVM use for each loop. Use PAGE to move from one Loop to the next.
 - STORE_USER_ALL 0x15..

If Module has to be turned on using ON/OFF command use ON_OFF_CONFIG 0x02 to change setting

Quick Start process—MLX xx0 up with SLX040 on PMBus with no external ENABLE control and needing output voltage other than 0.45V at start-up

1. VR_ENx is pulled upto 3.3V. 3.3V Source from module can be used with 10K resistor pull-up. This will keep Output Off when module is powered ON.
2. Power up module.s.
3. Configure required output voltage through PAGE **0x00** and VOUT_COMMAND **0x21**, for each output loop as applicable.
4. Configure the following if needed
 - VOUT_OV_FAULT_RESPONSE **0x41**.
 - VOUT_OV_FAULT_LIMIT **0x40**.
 - VOUT_OV_WARN_LIMIT **0x42**.
5. Configure OPERATION command to OFF (**0x00**) instead of the always ON(**0x80**) if ON/OFF control is desired through PMBus or else module will start up whenever Module receives input power in the future.
6. Configure ON_OFF_CONFIG **0x02** to change setting to **0x18** which will turn on or off module whenever commanded through the OPERATION COMMAND and ignore the ENABLE Pin.
7. If OPERATION COMMAND has been left at Always ON then module will turn on unless the OPERATION COMMAND was previously changed to OFF
8. If Changes are final and Configuration has to be stored in NVM use, Use PAGE to move from one Loop to the next. STORE_USER_ALL **0x15**.
9. Issue ON Command through OPERATION COMMAND (if it was previously set to OFF) to turn on module OUTPUT
10. Current Calibration of SLX040 as described in next section of this datasheet and update the following as per configuration
 - IOUT_OC_FAULT_LIMIT (0x46)
 - IOUT_OC_FAULT_RESPONSE (0x47)
 - IOUT_OC_WARN_LIMIT (0x4A)
11. If Changes are final and Configuration has to be stored in NVM use for each Loop. Use PAGE to move from one Loop to the next.
 - STORE_USER_ALL 0x15

Technical Specifications (continued)

Current Calibration (SLX040 on Loop 1 –only with MLX160 Master module)

In this application the SLX will power the same output bus as the MLX module it is paired with . Hence it will also be on the same output loop (Loop1) which is established in the MLX module. An expanded version of the flow chart is shown on the subsequent pages of the document.

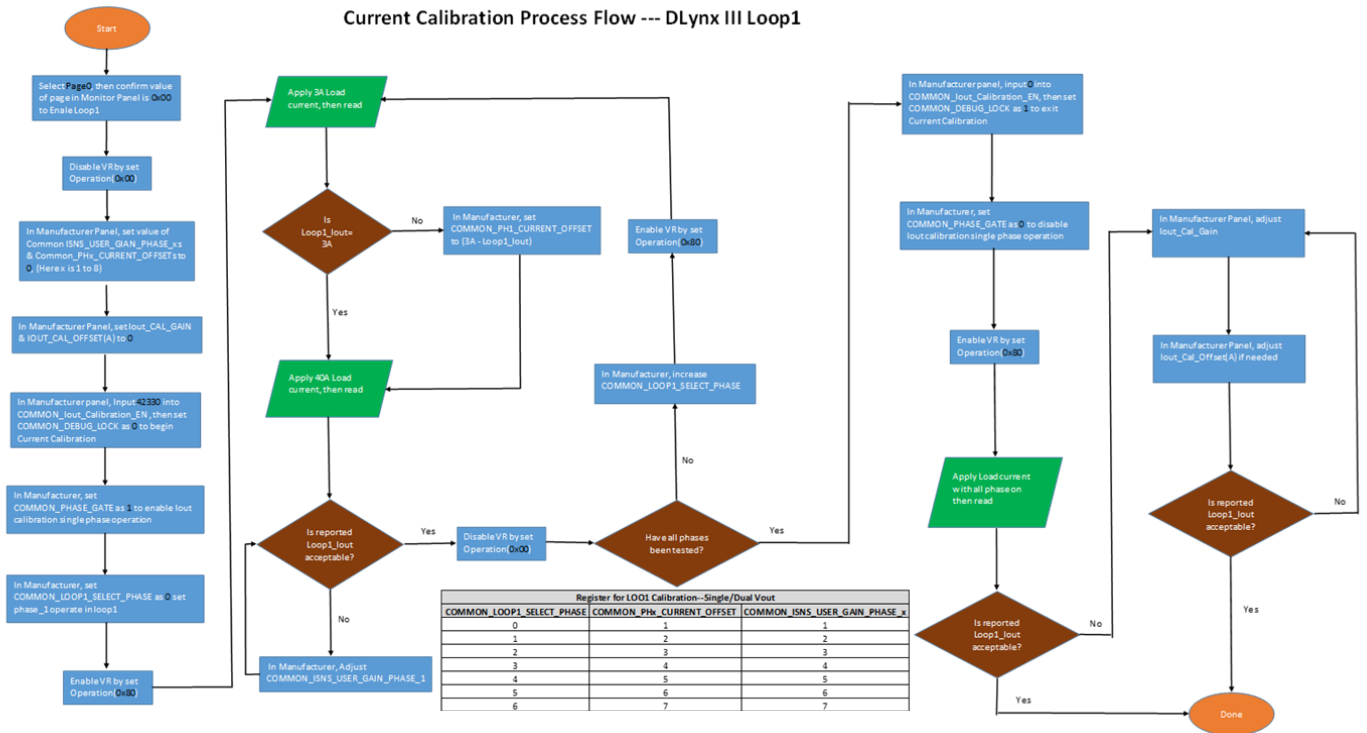

Figure 29. Output Current Calibration Process Flow—Loop 1

	0 → Calibrated during Manufacturing			x → Calibration required					
Output Rails	Master	Satellite	Ph1_Offset / Gain	Ph2_Offset / Gain	Ph3_Offset / Gain	Ph4_Offset / Gain	Ph5_Offset / Gain	Ph6_Offset / Gain	Ph7_Offset / Gain
Single Output	MLX160	SLX040	0	0	0	0	x		
Single Output	MLX160	2 x SLX040	0	0	0	0	x	x	
Single Output	MLX160	3 x SLX040	0	0	0	0	x	x	x

Table 3—Calibration Status of Master Modules and SLX040 on same loop.

Modules	Master	Satellite	Max Iout Loop 1	Max Iout Loop 2	Outputs	D0 PMBus Commands		
						Common_disable_Ou tput	Common_Loop1_Phase_Active_Max	Common_Loop1_Phase_Active_Max
MLX040 + SLX160	MLX160	SLX040	200A	N/A	Single	2	4	x
MLX080 + SLX160	MLX160	2 x SLX040	240A	N/A	Single	2	5	x
MLX120 + SLX160	MLX160	3 x SLX040	280A	N/A	Single	2	6	x

Table 4—D0 register settings for Master Modules and SLX040 on same loop.

Technical Specifications (continued)

Current Calibration (SLX040 on Loop 1(MLX160only)) - Continued (Part1). For the SLX040 calibrate Phases 4/5/6 (depending on number of SLX040s in parallel). Phases 0,1,2,3 are pre-identified for Master Modules

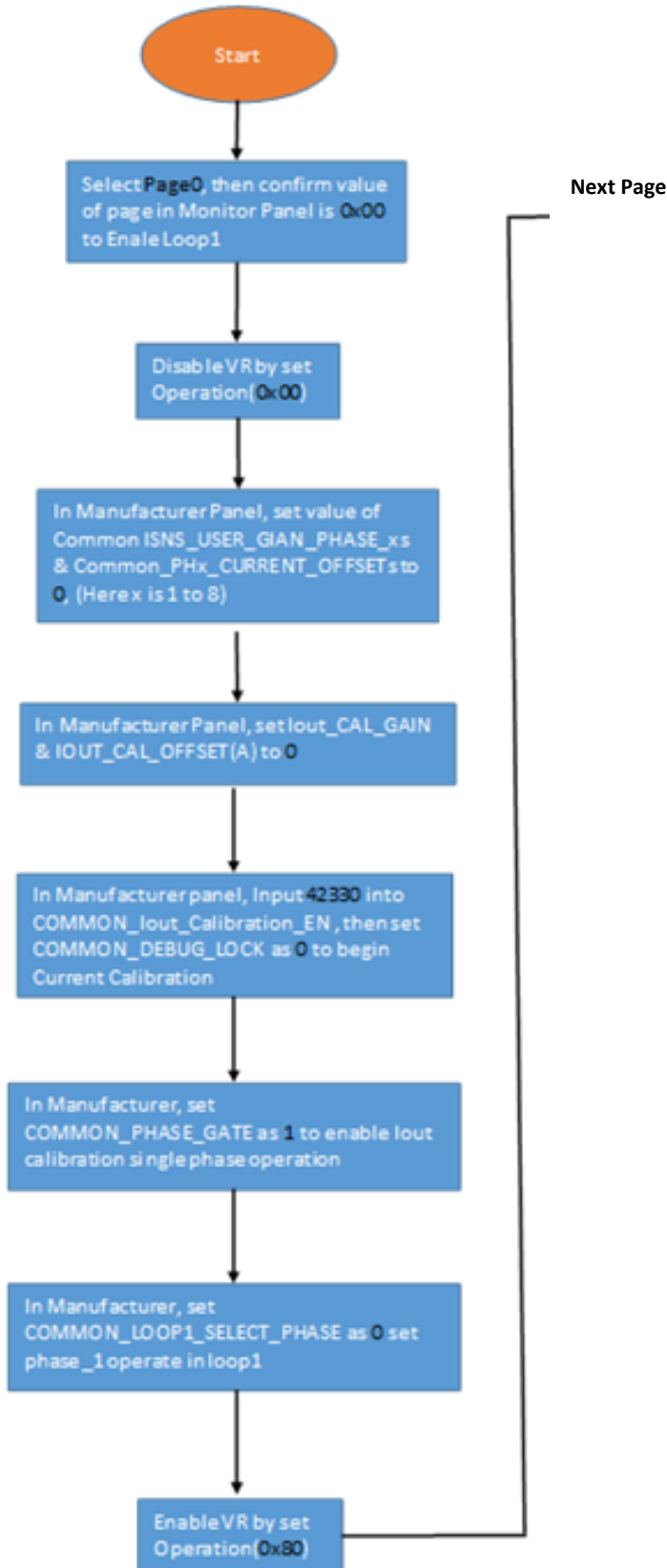

Technical Specifications (continued)

Current Calibration (SLX040 on Loop 1(MLX160only)) - Continued (Part 2)

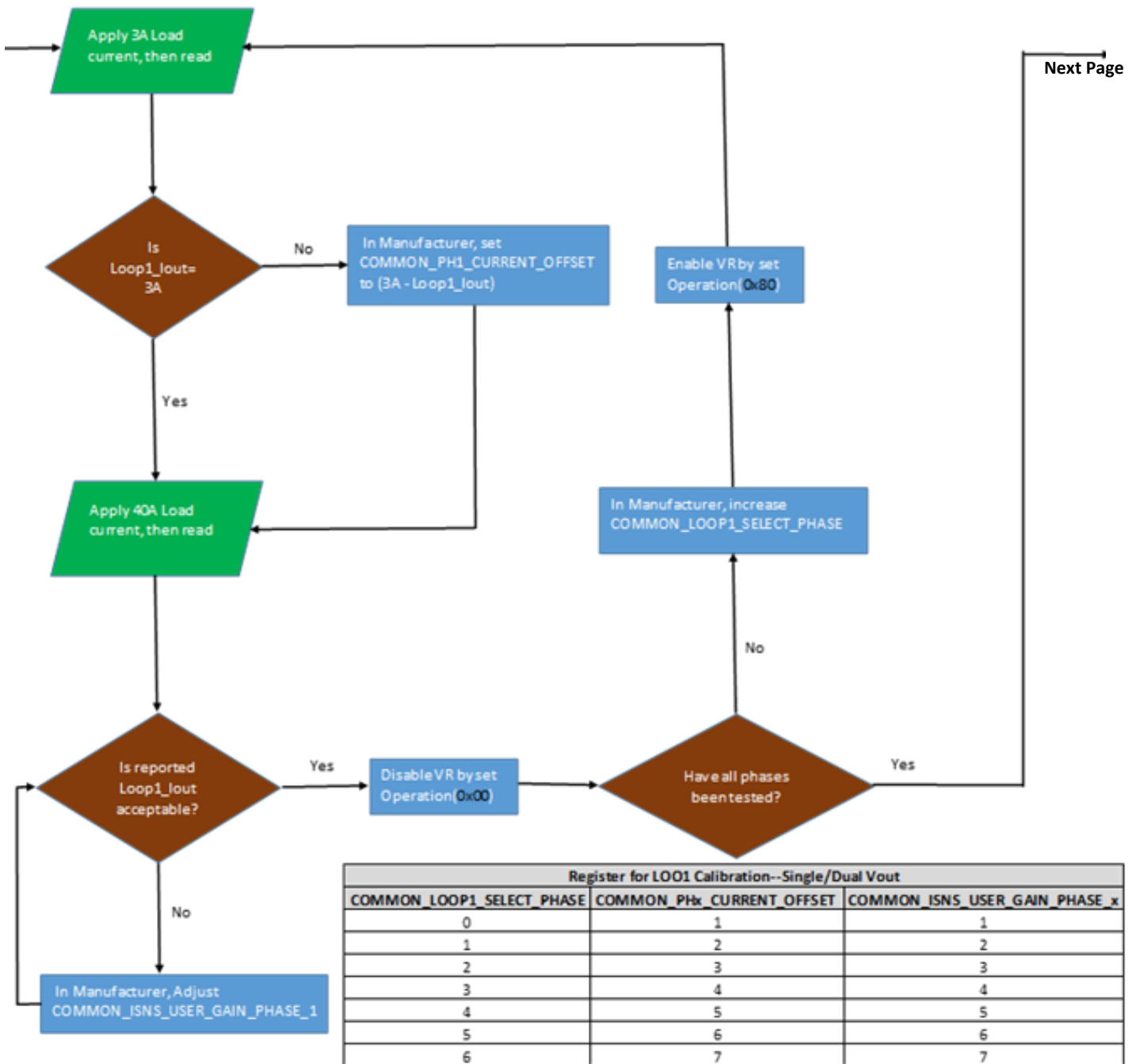

Register for LOO1 Calibration--Single/Dual Vout		
COMMON_LOOP1_SELECT_PHASE	COMMON_PHx_CURRENT_OFFSET	COMMON_ISNS_USER_GAIN_PHASE_x
0	1	1
1	2	2
2	3	3
3	4	4
4	5	5
5	6	6
6	7	7

For the SLX040 calibrate Phases 4/5/6. Phases 0,1,2,3 are pre-identified for Master Modules

Technical Specifications (continued)

Current Calibration (SLX040 on Loop 1(MLX160only)) - Continued (Part 3)

For the SLX04 calibrate Phases 4 / 5/ 6. Phases 0,1,2,3 are pre-identified for Master Modules

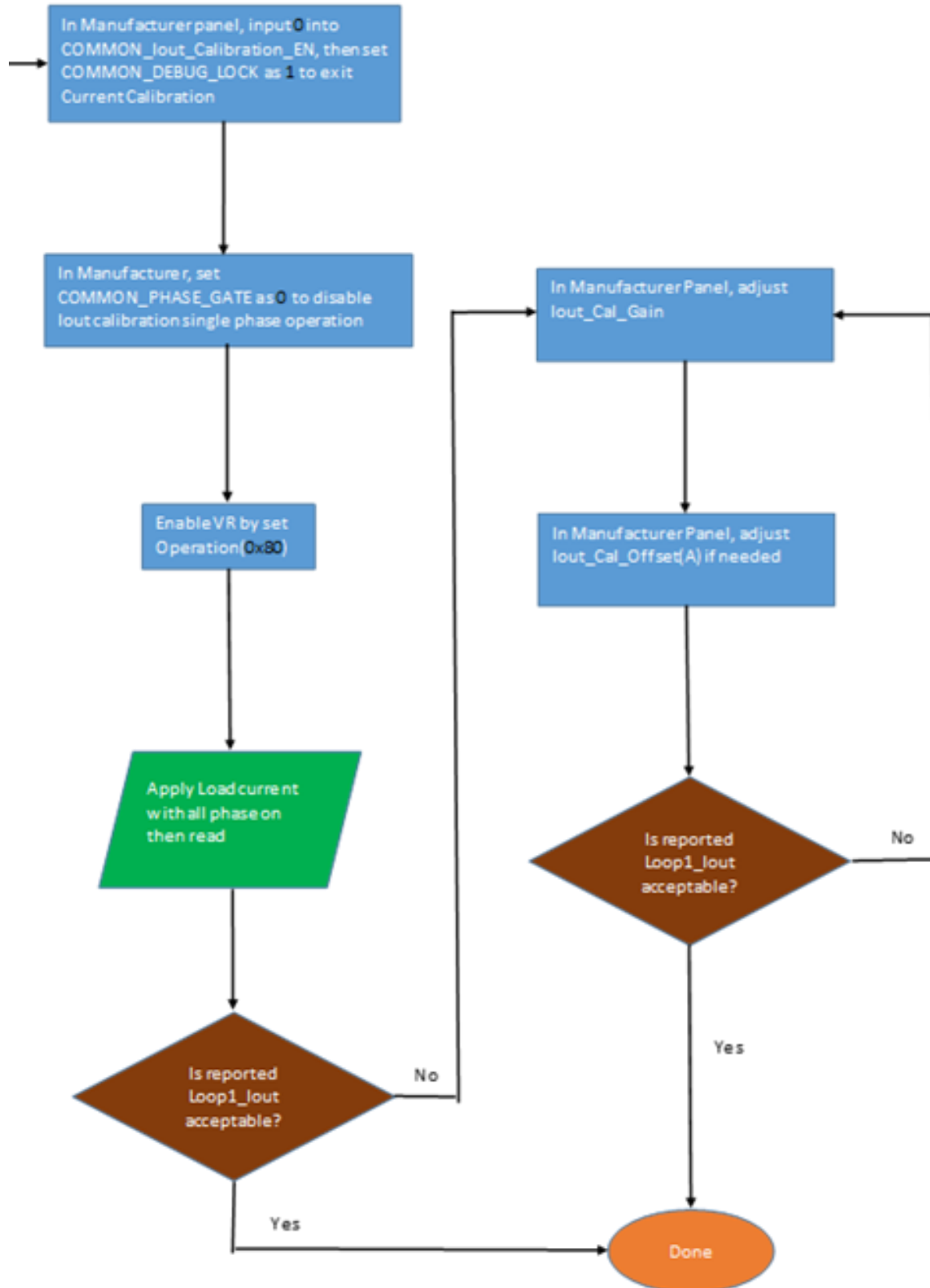

Technical Specifications (continued)

Current Calibration (SLX040 on Loop 2—possible with any MLX module)

In this application the SLX will power a separate output bus from the MLX module it is paired with . Hence it will be a separate output loop (Loop2) which is established in the controller of the MLX module. An expanded version of the flow chart is shown on the subsequent pages of the document.

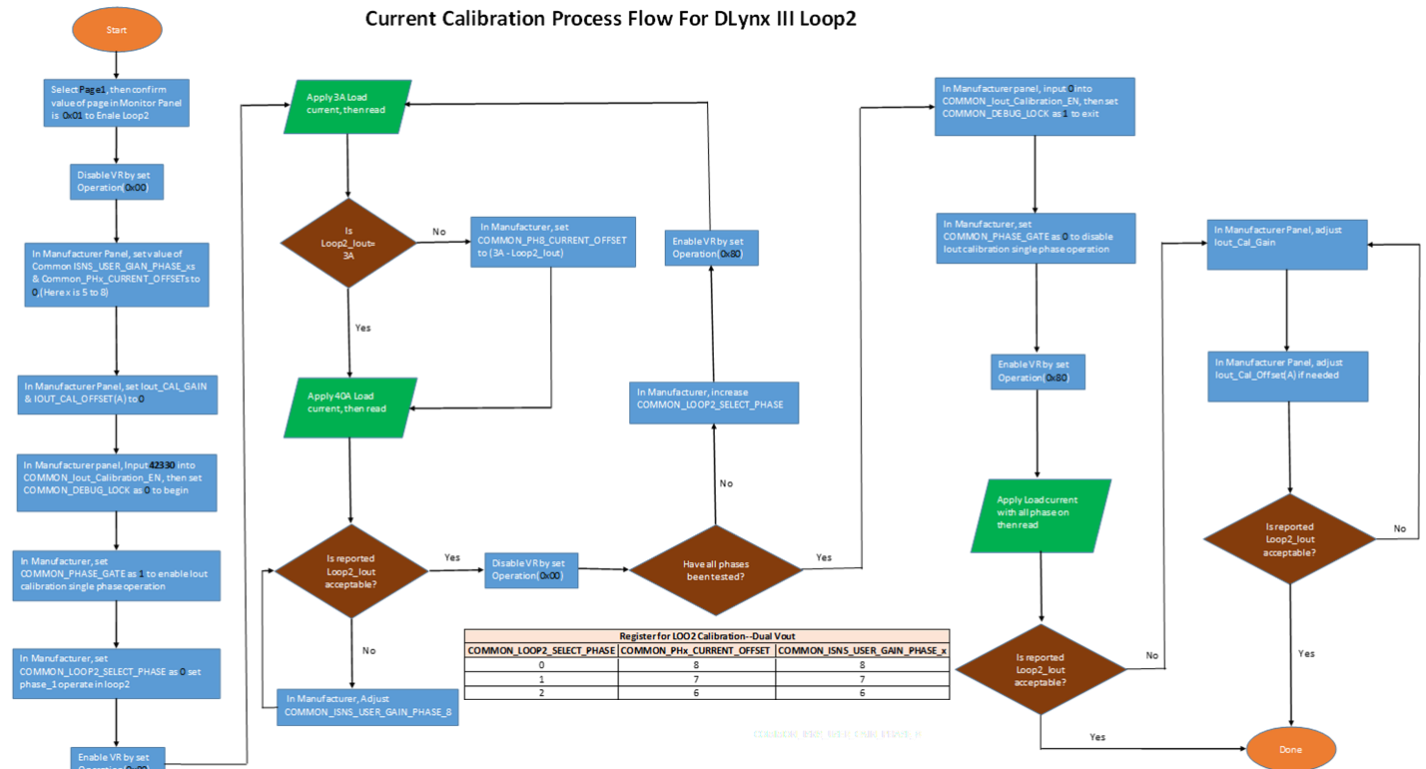

Figure 30. Output Current Calibration Process Flow—Loop 2

Output Rails	0 → Calibrated during Manufacturing			x → Calibration required					
	Master	Satellite	Ph1_Offset/Gain	Ph2_Offset/Gain	Ph3_Offset/Gain	Ph4_Offset/Gain	Ph5_Offset/Gain	Ph6_Offset/Gain	Ph7_Offset/Gain
Dual Output	MLX040	SLX040	0				x		
Dual Output	MLX080	SLX040	0	0			x		
Dual Output	MLX120	SLX040	0	0	0		x		
Dual Output	MLX160	SLX040	0	0	0	0	x		
Dual Output	MLX040	2 x SLX040	0				x	x	
Dual Output	MLX080	2 x SLX040	0	0			x	x	
Dual Output	MLX120	2 x SLX040	0	0	0		x	x	
Dual Output	MLX160	2 x SLX040	0	0	0	0	x	x	
Dual Output	MLX040	3 x SLX040	0				x	x	x
Dual Output	MLX080	3 x SLX040	0	0	0		x	x	x
Dual Output	MLX120	3 x SLX040	0	0	0		x	x	x
Dual Output	MLX160	3 x SLX040	0	0	0	0	x	x	x

Table 5—Calibration Status of Master Modules and SLX040 in dual loop

Modules	Master	Satellite	Max Iout Loop 1	Max Iout Loop 2	Outputs	D0 PMBus Commands		
						Common_disable_Ou tput	Common_Loop1_Phase Active_Max	Common_Loop2_Phase Active_Max
MLX040 SLX040	MLX040	SLX040	40A	40A	Dual	0	0	0
MLX080 SLX040	MLX080	SLX040	80A	40A	Dual	0	1	0
MLX120 SLX040	MLX120	SLX040	120A	40A	Dual	0	2	0
MLX160 SLX040	MLX160	SLX040	160A	40A	Dual	0	3	0
MLX040 2 x SLX040	MLX040	2 x SLX040	40A	80A	Dual	0	0	1
MLX080 2 x SLX040	MLX080	2 x SLX040	80A	80A	Dual	0	1	1
MLX120 2 x SLX040	MLX120	2 x SLX040	120A	80A	Dual	0	2	1
MLX160 2 x SLX040	MLX160	2 x SLX040	160A	80A	Dual	0	3	1
MLX040 3 x SLX040	MLX040	3 x SLX040	40A	120A	Dual	0	0	2
MLX080 3 x SLX040	MLX080	3 x SLX040	80A	120A	Dual	0	1	2
MLX120 3 x SLX040	MLX120	3 x SLX040	120A	120A	Dual	0	2	2
MLX160 3 x SLX040	MLX160	3 x SLX040	160A	120A	Dual	0	3	2

Table 6—D0 register settings for Master Modules and SLX040 in dual loop

Technical Specifications (continued)

Current Calibration (SLX040 on Loop 2) - Continued (Part1). For the SLX040 on Loop 2 calibrate Phases 0/1/2

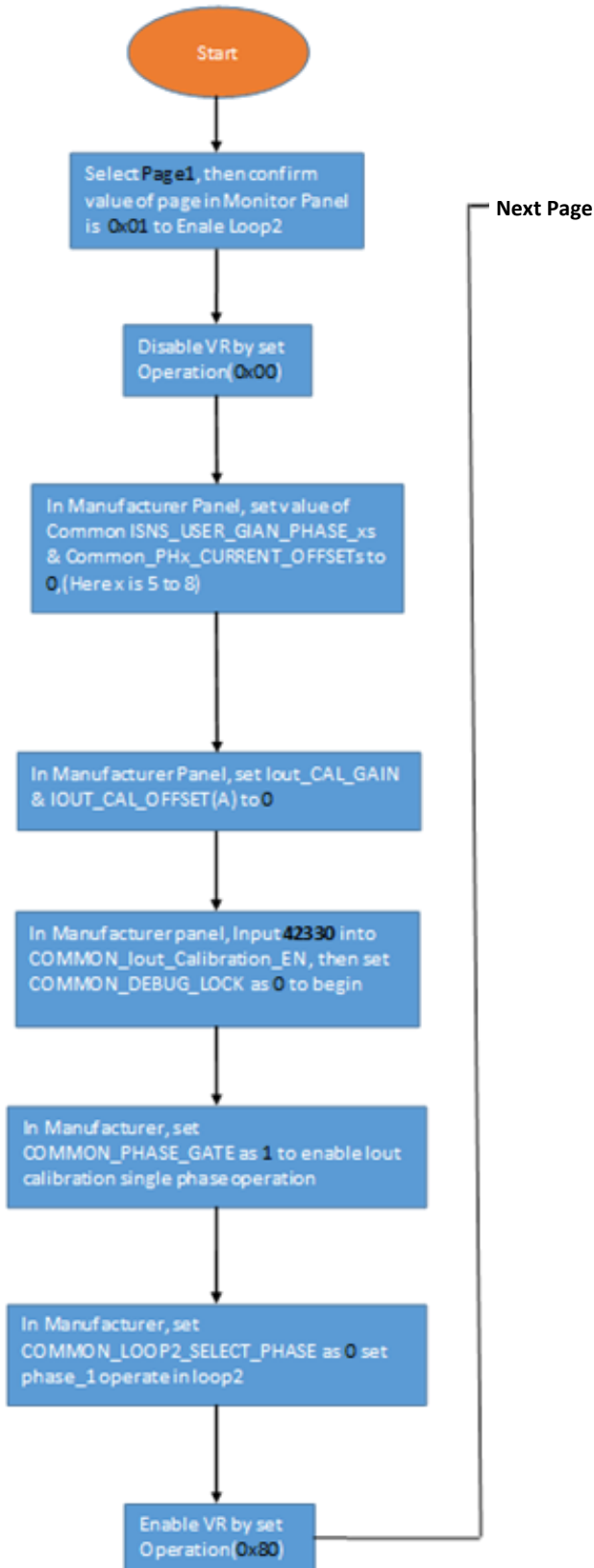

Technical Specifications (continued)

Current Calibration (SLX040 on Loop 1) - Continued (Part 2)

For the SLX040 on Loop 2 calibrate Phases 0,1,2

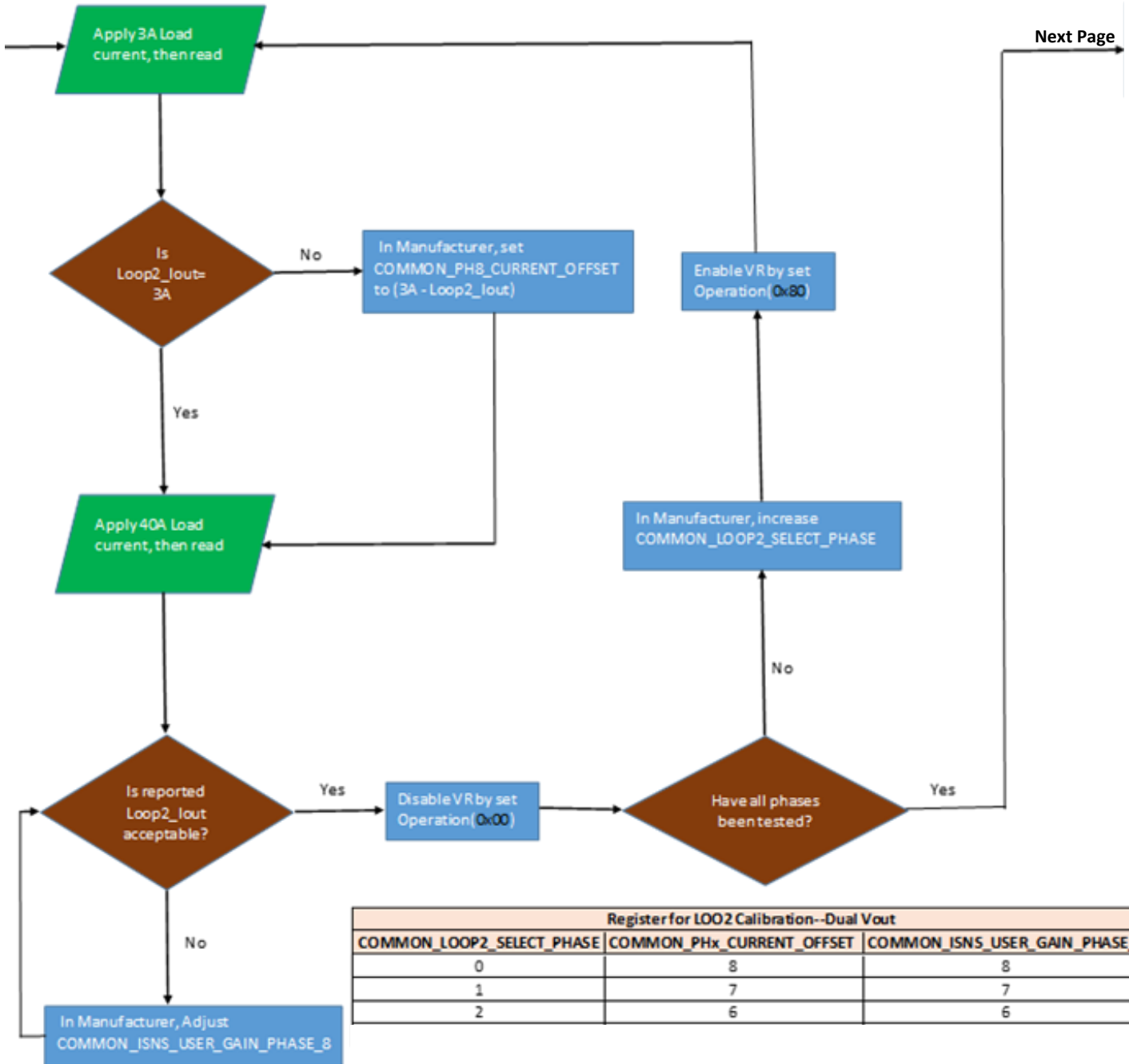

Register for LOO2 Calibration--Dual Vout		
COMMON_LOOP2_SELECT_PHASE	COMMON_PHx_CURRENT_OFFSET	COMMON_ISNS_USER_GAIN_PHASE_x
0	8	8
1	7	7
2	6	6

Technical Specifications (continued)

Current Calibration (SLX040 on Loop 2) - Continued (Part 3)

For the SLX040 calibrate Phases 0,1 and 2

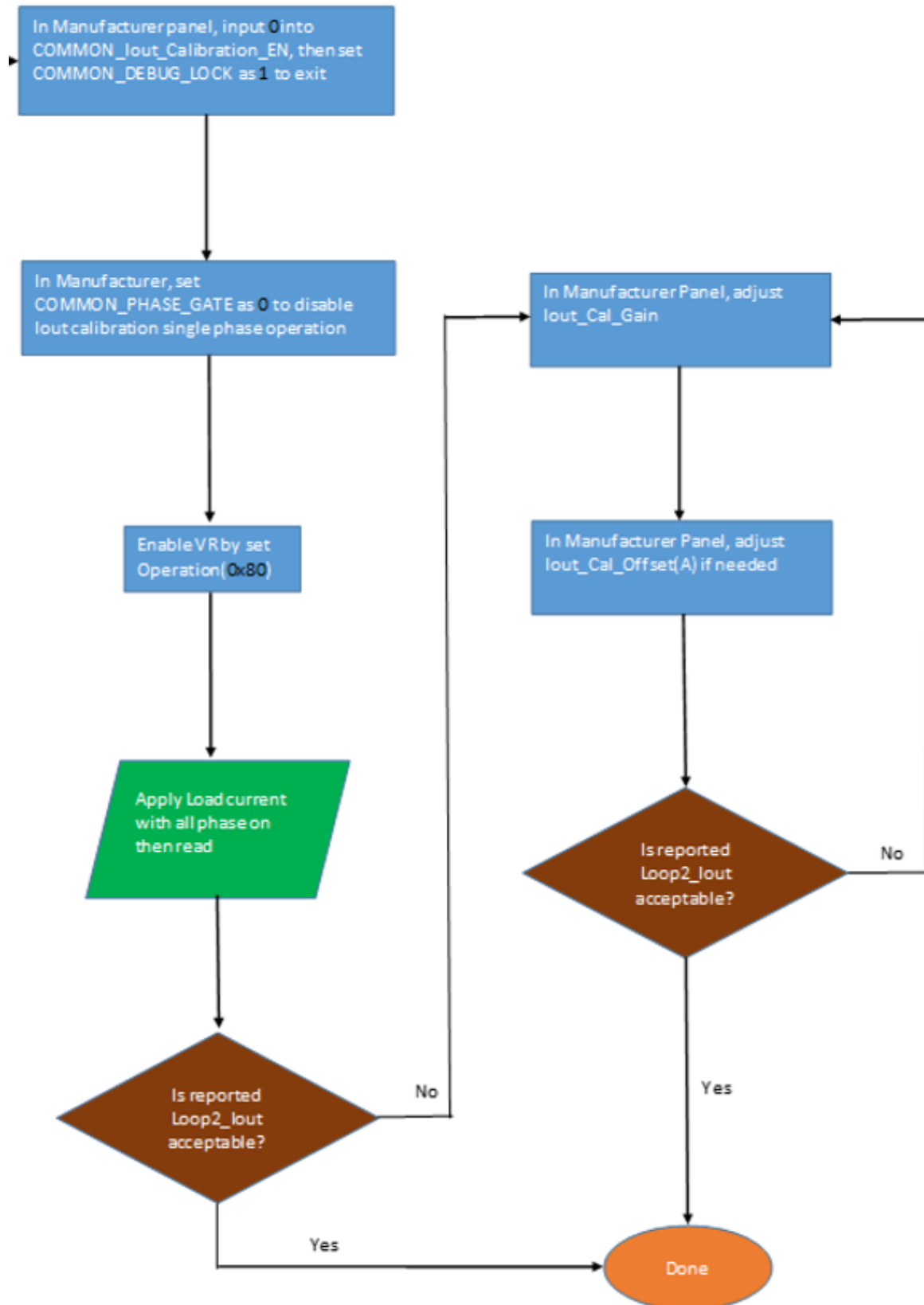

Technical Specifications (continued)

Layout considerations

DONOT PLACE SATELLITE MODULE MORE THAN 6 INCHES APART FROM MASTER MODULE

The evaluation board layout and schematic files are available for interested users. These can be downloaded through the webpage or by contacting our Field Applications Engineer through the help section of the webpage. The electrical and the thermal characterization of the SLX040A0XY3-SRZ module has been done on evaluation boards with layout as shown in Fig28.

The SLX040 just has a power switching section without a controller section. Following are the recommendations for this converter.

1. For Thermal and Current Carrying reasons, it is recommended to have four 20 mil heavy plated filled vias on each of the power pins. Copper plating of vias should be 2 mils if possible.
2. 12 mil vias are recommended for all Signal Pins
3. Additional thermal vias can be placed on ground plane around module and signal pins

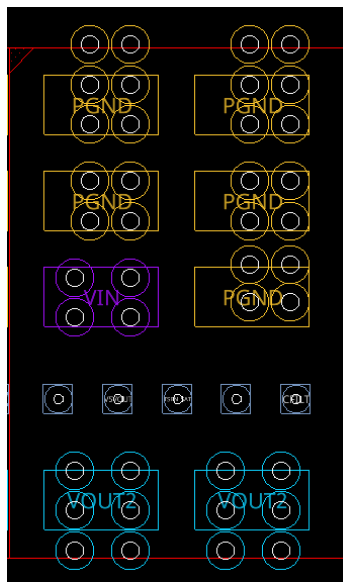

Figure 28. Example of Pad Layout with Vias

4. Input Voltage for each of the phases can be laid out on the same layer as shown below:

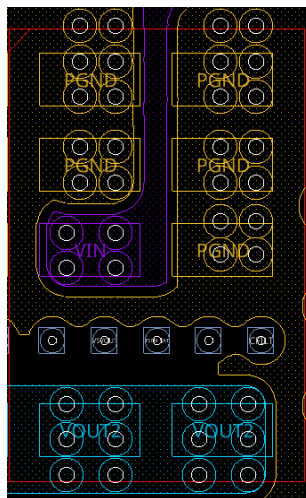
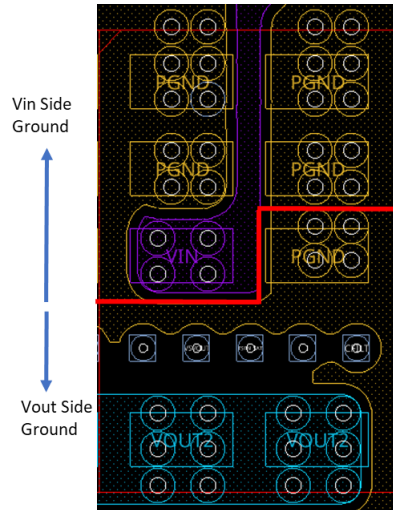

Figure 29. Example of Pad Layout with Vias

Technical Specifications (continued)

Layout considerations (continued)

5. It is Possible to Split the Grounds at this location based on customer design layout practices; the POL module has a single ground



6. On bottom side of the customer board place a

minimum of 10uf and 1uf input capacitor directly

Figure 30. Example of split input-output ground

under Vin and keep additional input capacitance as close to Vin under each of the phases. Additional input capacitance can be placed on top surface of board.

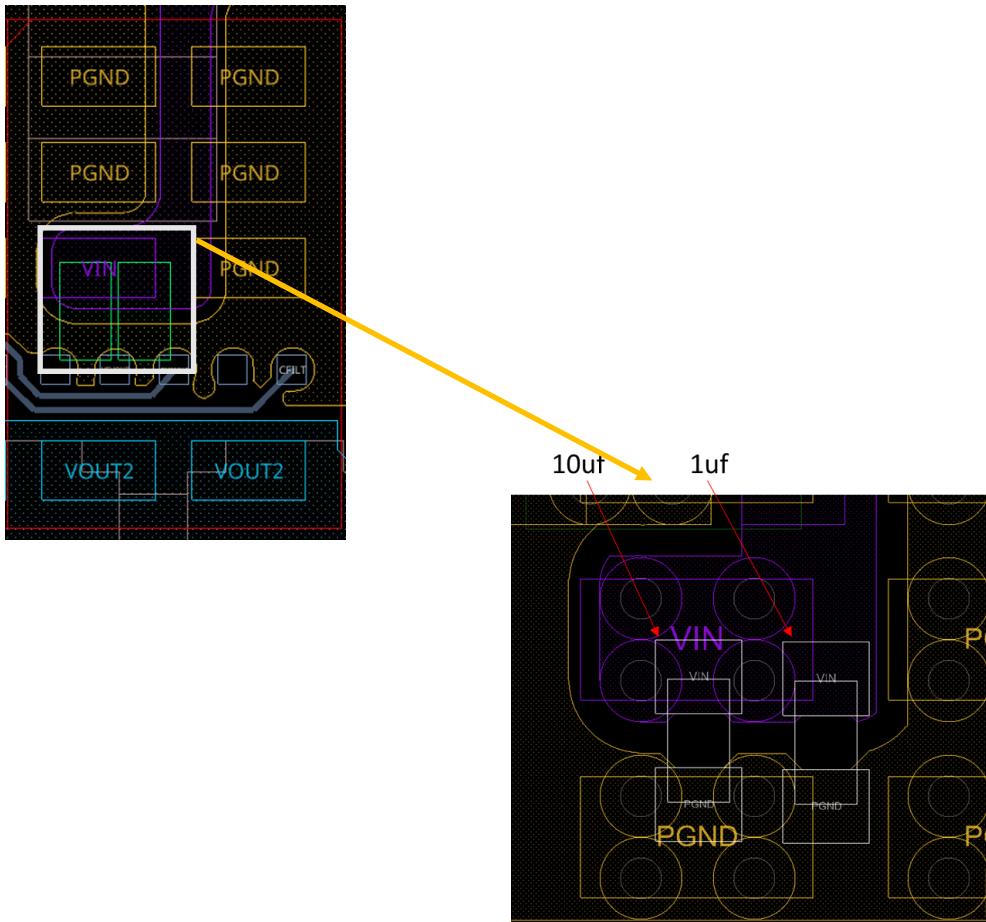

Figure 31. Example of Input capacitor placement and routing.

Technical Specifications (continued)

Layout considerations (continued)

7. Input capacitance for each phase is recommended to be as close as possible to the V_{in} of the module

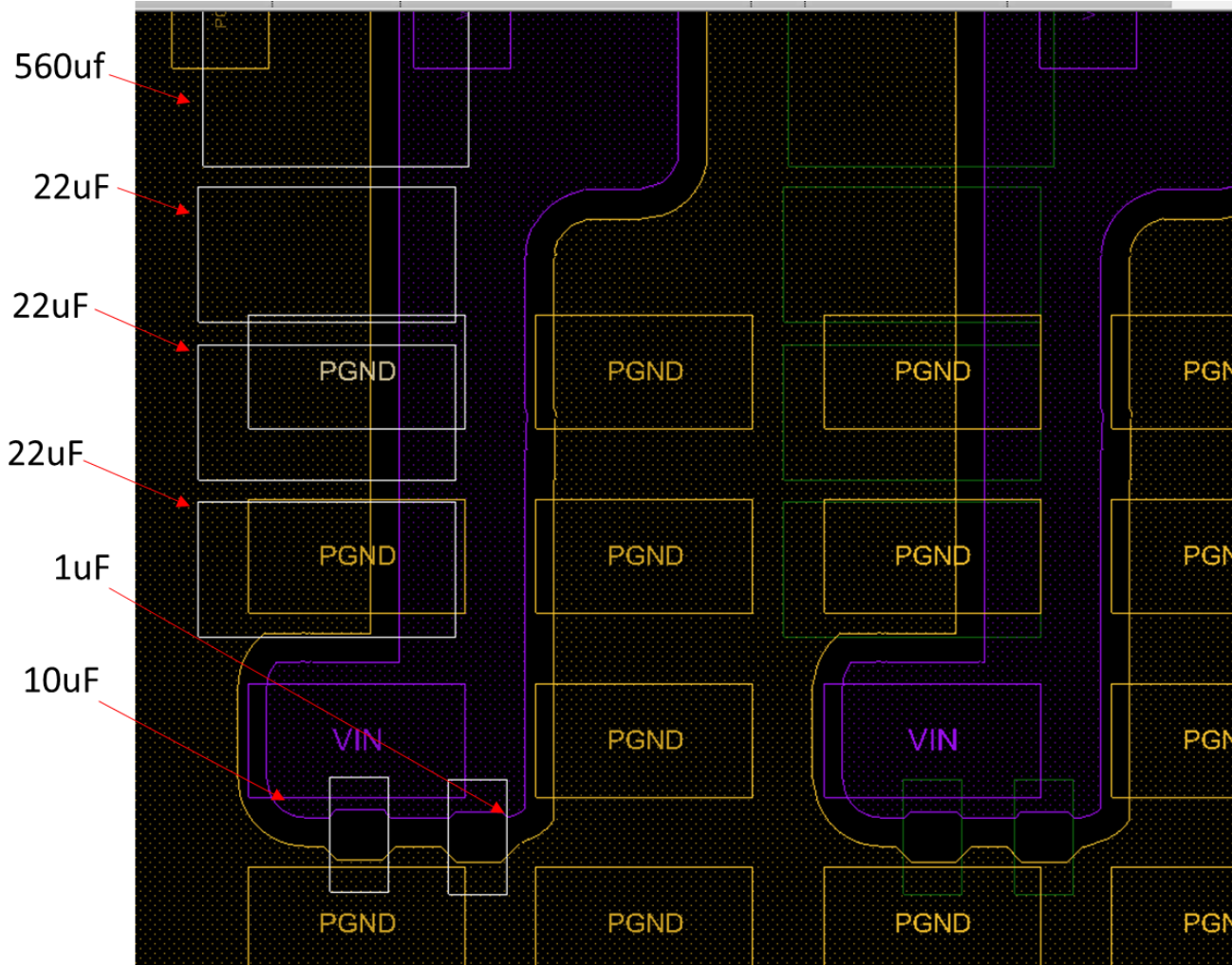
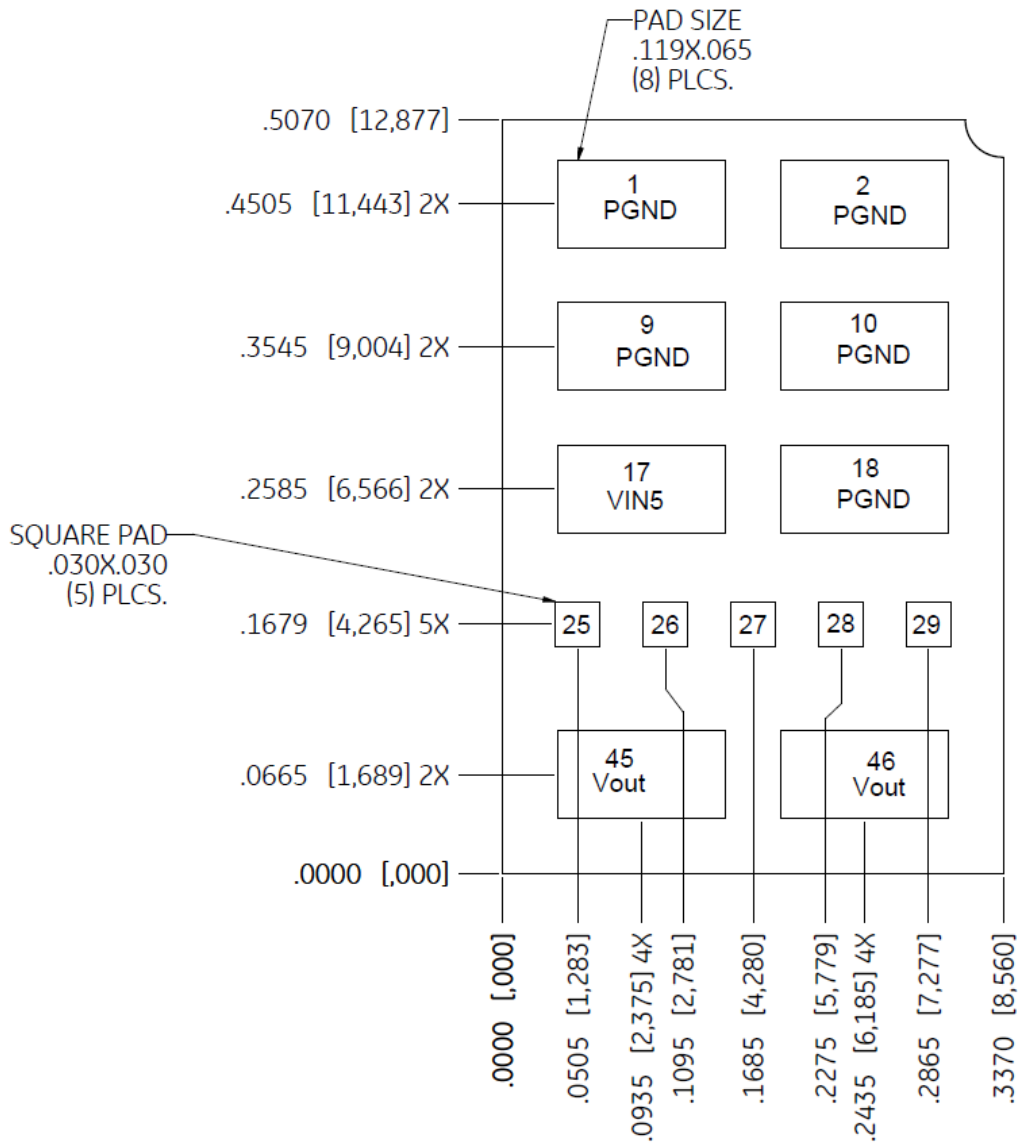

Figure 32. Input capacitor placement

Technical Specifications (continued)

Recommended Pad Layout and Pin Description



PIN	FUNCTION
1	PGND
2	PGND
9	PGND
10	PGND
17	VIN5
18	PGND
25	PWM5_SAT_L1/PWM4_SAT_L2
26	V5V_5
27	TSEN5_SAT_L1/TSEN4_SAT_L2
28	MON5_SAT_L1/IMON4_SAT_L2
29	CFILT5
45	VOUT
46	VOUT

Technical Specifications (continued)

Pin Assignment Table

Pin	Label	Type	Description
1	PGND	PWR	Ground Reference for the module, Rail Return.
2	PGND	PWR	Ground Reference for the module, Rail Return.
9	PGND	PWR	Ground Reference for the module, Rail Return.
10	PGND	PWR	Ground Reference for the module, Rail Return.
17	VIN5	Input	Input voltage rail. Minimum recommended capacitance 1 x 560uF (electrolytic), 4 x 22 μF, 4x 10μF, 2 x 1 μF .
18	PGND	PWR	Ground Reference for the module, Rail Return.
25	PWM5_SAT_L1/ PWM4_SAT_L2	Input	Pulse Width Modulation Output for external Power stage in Satellite.
26	V5V_5	Input	Auxiliary 5V low power bus. For Phase 5.
27	TSEN5_SAT_L1/ TSEN4_SAT_L2	Output	External Temperature Sense (Loop 1 or loop2).
28	IMON5_SAT_L1/ IMON4_SAT_L2	O	I _{mon} : Analog output current monitor. This pin provides an analog output voltage proportional to the average output current. The full-scale IMON voltage is 2.55 V. 0 A corresponds to 5 mV voltage at IMON.
29	CFILT5	Input	1.8 V from Master.
45	VOUT	Output	Output voltage rail. Connect the output filter capacitors. Minimum recommended capacitance 2 x 560μF (polymer), 24x 47 μF, 5x 22 μF, 1x 0.1μF, 1x 0.047μF.
46	VOUT	Output	Output voltage rail. Connect the output filter capacitors. Minimum recommended capacitance 2 x 560μF (polymer), 24x 47 μF, 5x 22 μF, 1x 0.1μF, 1x 0.047μF.

Technical Specifications (continued)

Physical dimensions

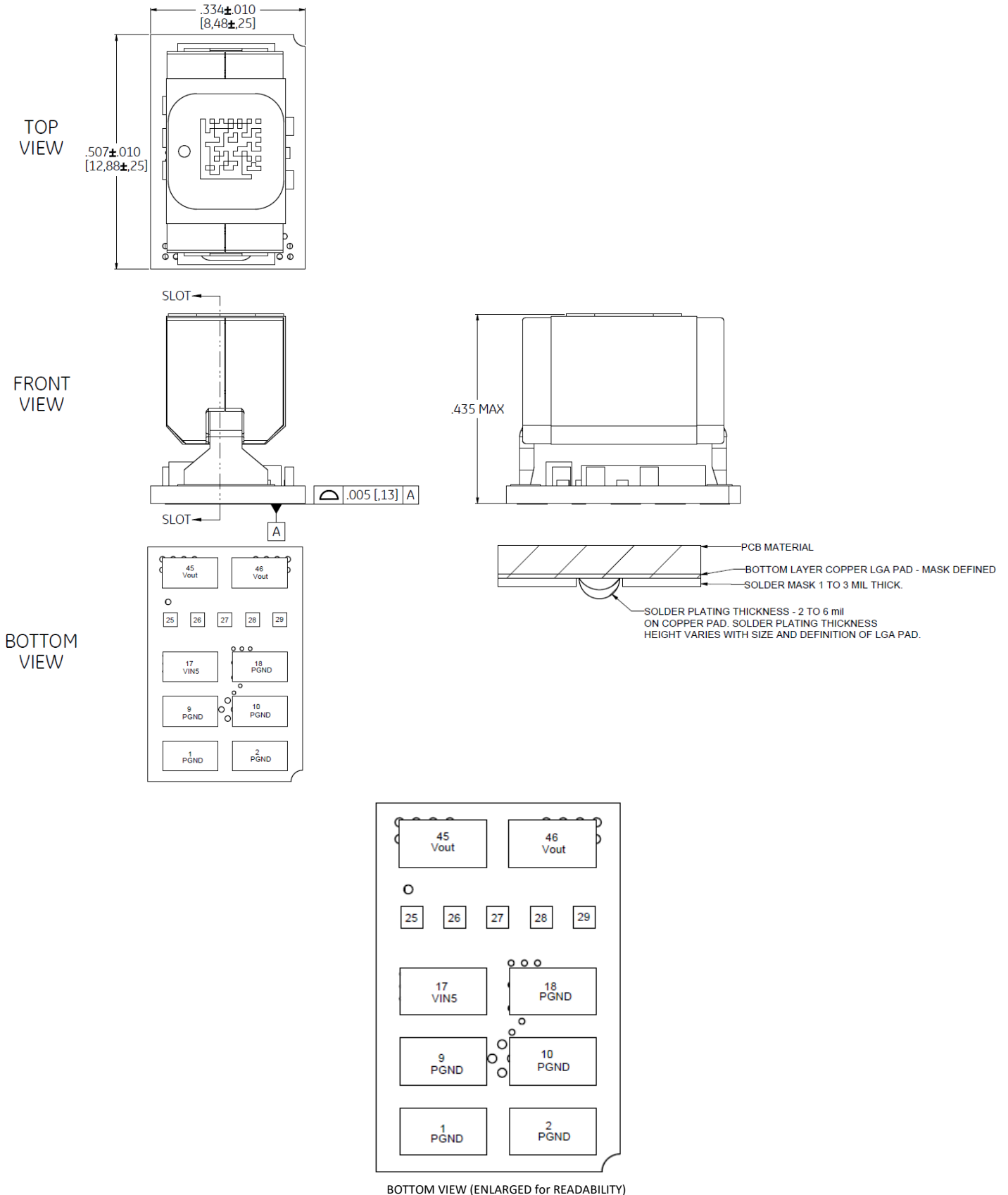

Application Circuit

Master(MLX160 only)—Satellite Connections—Loop 1 (Common Output)

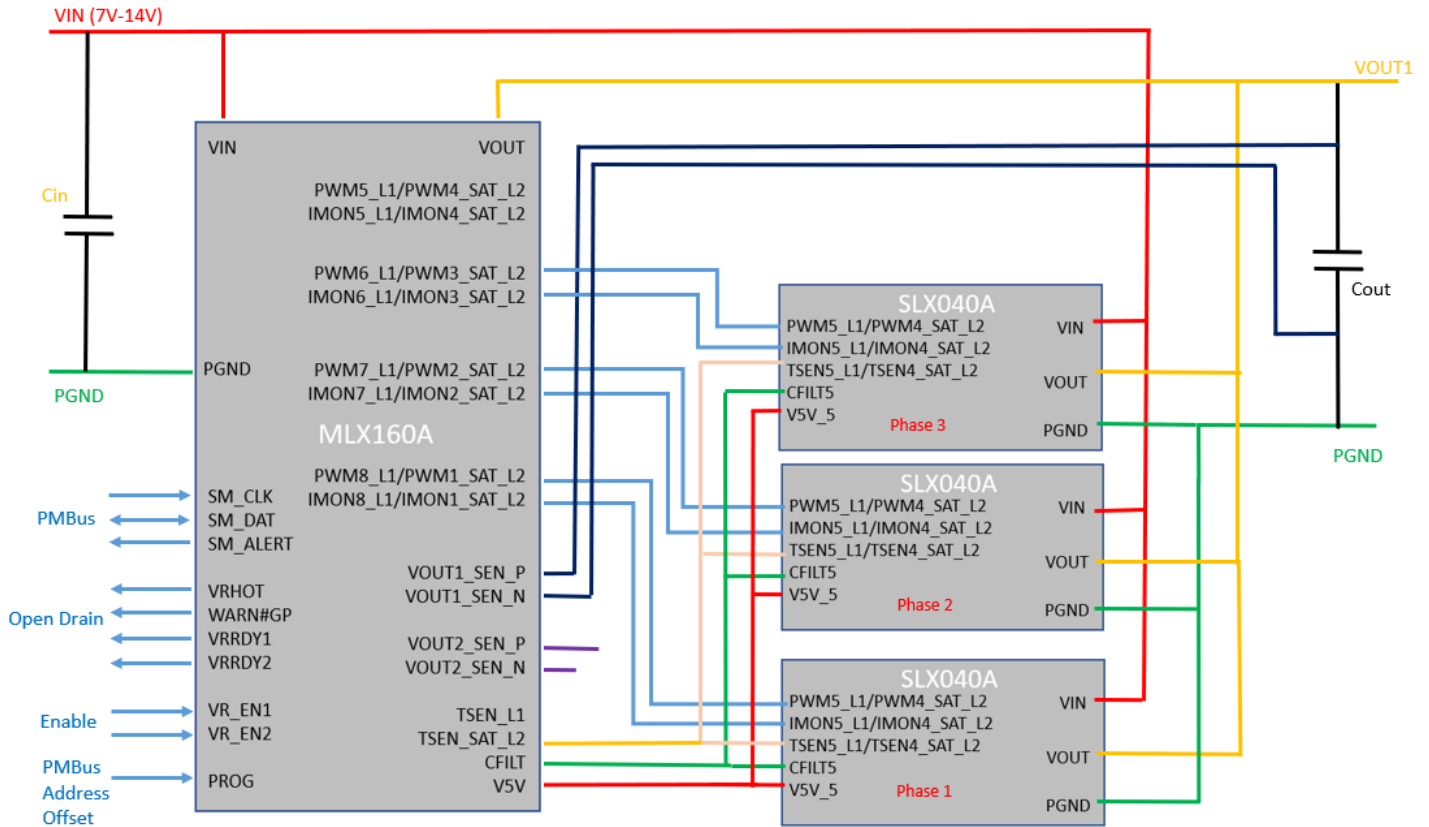

Master (MLX160/120/80/40) —Satellite Connections—Loop 1 and Loop 2 (Separate Output)

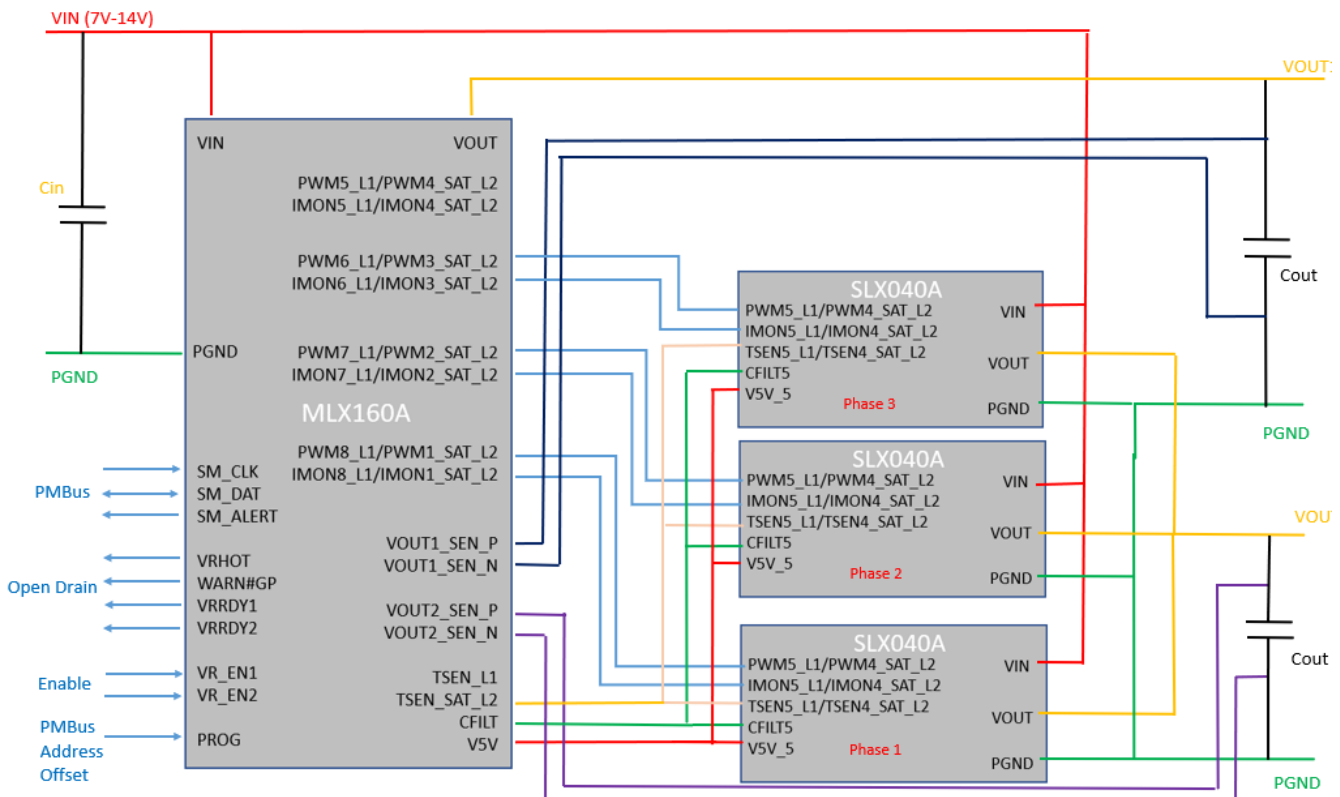

Application Circuit

$V_{IN} = 12V$

$V_{out} = 1V_{out}$

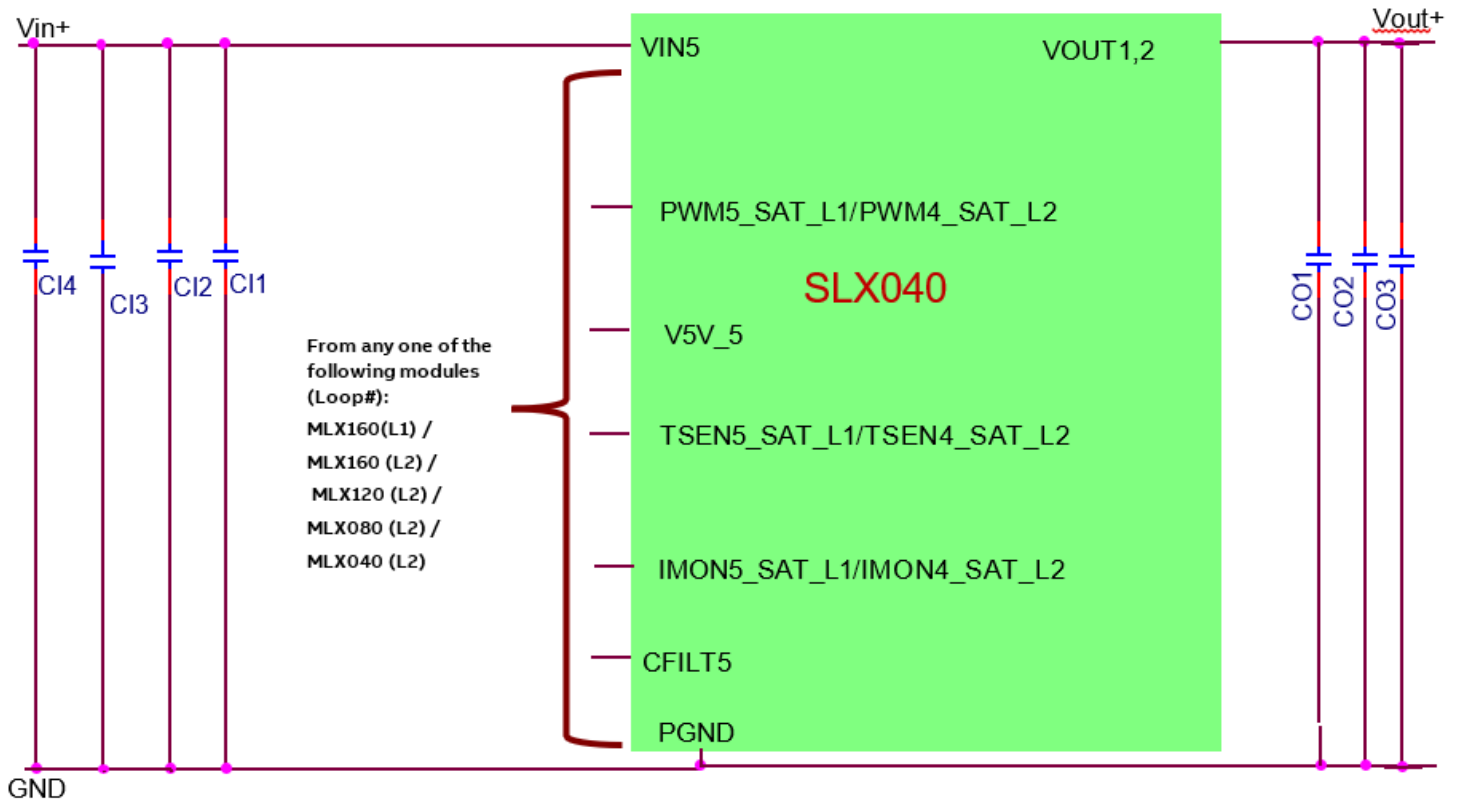

L1– Loop 1, L2—Loop 2.....Loop2 Phase numbering sequence increments in reverse order (4,3,2)

C1 – 4 banks (1 μ F + 1 μ F ceramic) – 8 caps total

C2 – 4 Banks (4 x 10 μ F ceramic) – 16 caps total

C3 – 4 Banks (4 x 22 μ F ceramic) – 16 caps total

C4 – 4 Banks (1 x 560 μ F electrolytic) – 4 caps total

CO1 – 4 x 0.047 μ F + 4 x 0.1 μ F - ceramic

CO2 – 15 x 22 μ Fceramic + 73 x 47 μ Fceramic + 6 x 470 μ F polymer or electrolytic

CO3 – 1 x 1500pF(0402) + 1 x 2200pF(0402) +1 x 0.022 μ F(0402) + 1 x 0.1 μ F(0402) — all ceramic

Technical Specifications (continued)

Thermal Considerations

Power modules operate in a variety of thermal environments; however, sufficient cooling should always be provided to help ensure reliable operation. Considerations include ambient temperature, airflow, module power dissipation, and the need for increased reliability. A reduction in the operating temperature of the module will result in an increase in reliability. The thermal data presented here is based on physical measurements taken in a wind tunnel. The test set-up is shown in Figure 28. The preferred airflow direction for cooling the module and the thermal reference points, T_{ref} used in the specifications are shown in Figure 29. For reliable operation the temperatures at these points should not exceed 120°C (IC100) and 115°C (C100). The output power of the module should not exceed the rated power of the module ($V_{o,set} \times I_{o,max}$). Please refer to the Application Note “Thermal Characterization Process for Open-Frame Board-Mounted Power Modules” for a detailed discussion of thermal aspects including maximum device temperatures. Increased airflow over the module enhances the heat transfer via convection. The thermal derating of figures 2, 8, 14 and 20 show the maximum output current that can be delivered by each module in the indicated orientation without exceeding the maximum T_{ref} temperature versus local ambient temperature (T_A) for several air flow conditions. The thermal derating curves were generated using a 12 layer evaluation board with 3oz copper in inner layers and 2 oz in outer layers

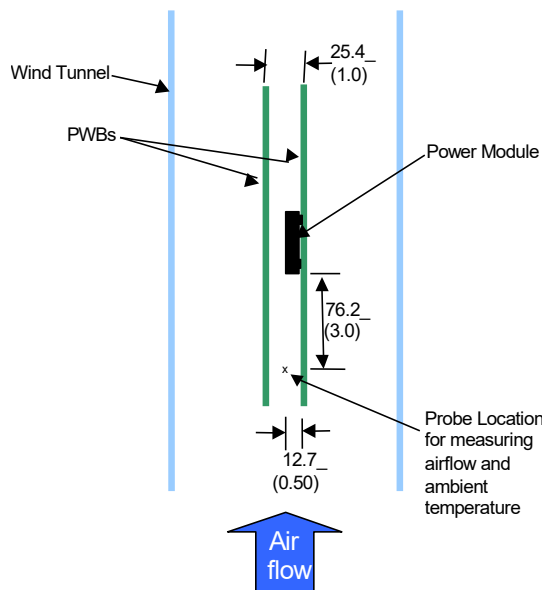

Figure 28. Thermal Test Setup.

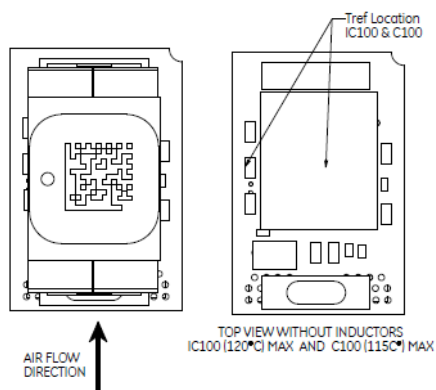
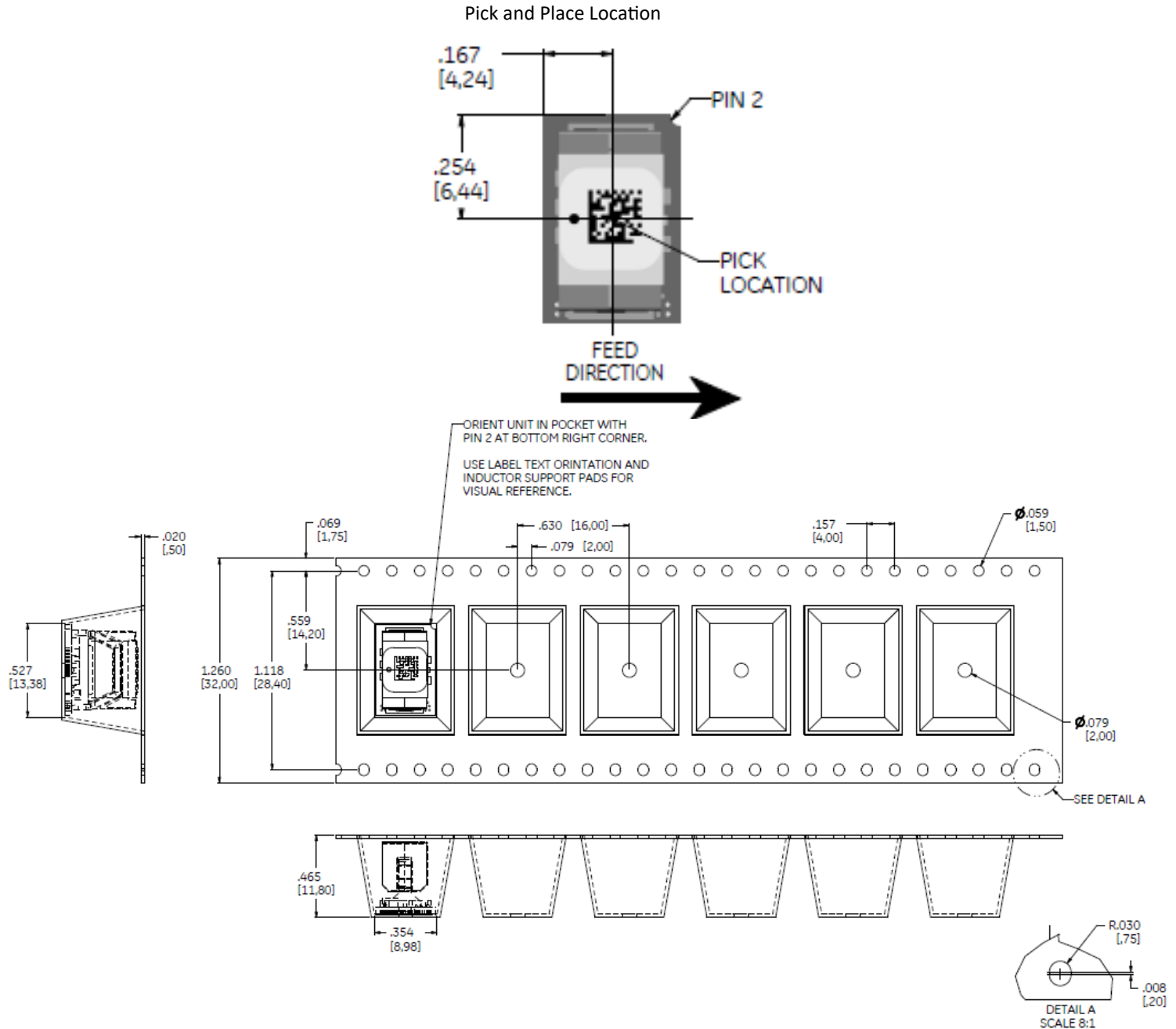

Figure 29. Preferred airflow direction and the location of the thermal reference points

Technical Specifications (continued)

Packaging Details

The SLX040 Open Frame modules are supplied in tape & reel as standard. Modules are shipped in quantities of 160 modules per reel. All Dimensions are in millimeters and (in inches).



Reel Dimensions:

Outside Dimensions: 330.2mm (13")

Inside Dimensions: 177.8 mm (7")

Tape Width: 32.00mm (1.260")

Technical Specifications (continued)

Surface Mount Information

Pick and Place

The SLX040 Open Frame modules use an open frame construction and are designed for a fully automated assembly process. The modules are fitted with a label designed to provide a large surface area for pick and place operations. The label meets all the requirements for surface mount processing, as well as safety standards, and is able to withstand reflow temperatures of up to 300 °C. The label also carries product information such as product code, serial number and the location of manufacture.

Nozzle Recommendations

Stencil thickness of 5 mils minimum must be used for this product. The module weight has been kept to a minimum by using open frame construction. Variables such as nozzle size, tip style, vacuum pressure and placement speed should be considered to optimize this process. The minimum recommended inside nozzle diameter for reliable operation is 3mm. The maximum nozzle outer diameter, which will safely fit within the allowable component spacing, is 7 mm.

Bottom Side / First Side Assembly

This module is not recommended for assembly on the bottom side of a customer board. If such an assembly is attempted, components may fall off the module during the second reflow process.

Lead Free Soldering

The modules are lead-free (Pb-free) and RoHS compliant and fully compatible in a Pb-free soldering process. Failure to observe the instructions below may result in the failure of or cause damage to the modules and can adversely affect long-term reliability.

Pb-free Reflow Profile

Power Systems will comply with J-STD-020 Rev. D (Moisture/Reflow Sensitivity Classification for Nonhermetic Solid State Surface Mount Devices) for both Pb-free solder profiles and MSL classification procedures. This standard provides a recommended forced-air-convection reflow profile based on the volume and thickness of the package (table 4-2). The suggested Pb-free solder paste is Sn/Ag/Cu (SAC). The recommended linear reflow profile using Sn/Ag/Cu solder is shown in Fig. 30. Soldering outside of the recommended profile requires testing to verify results and performance.

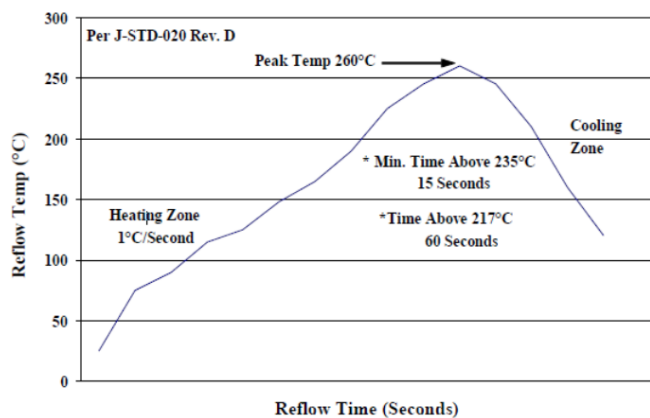

Figure 30. Recommended linear reflow profile using Sn/Ag/Cu solder

Technical Specifications (continued)

Surface Mount Information (continued)

MSL Rating

The SLX040A0XY3-SRZ Open Frame modules have a MSL rating of 2A.

Storage and Handling

The recommended storage environment and handling procedures for moisture-sensitive surface mount packages is detailed in J-STD-033 Rev. A (Handling, Packing, Shipping and Use of Moisture/Reflow Sensitive Surface Mount Devices). Moisture barrier bags (MBB) with desiccant are required for MSL ratings of 2 or greater. These sealed packages should not be broken until time of use. Once the original package is broken, the floor life of the product at conditions of 30°C and 60% relative humidity varies according to the MSL rating (see J-STD-033A). The shelf life for dry packed SMT packages will be a minimum of 12 months from the bag seal date, when stored at the following conditions: < 40° C, < 90% relative humidity.

Post Solder Cleaning and Drying Considerations

Post solder cleaning is usually the final circuit-board assembly process prior to electrical board testing. The result of inadequate cleaning and drying can affect both the reliability of a power module and the testability of the finished circuit-board assembly. For guidance on appropriate soldering, cleaning and drying procedures, refer to Board Mounted Power Modules: Soldering and Cleaning Application Note (AN04-001).

Technical Specifications (continued)

Family Options

Approved Combinations:

Output Current	Output Configuration in Master + Satellite Combination	Master Series	Satellite Series
40	Single Output	MLX040	None
40 + 40*	Dual Output	MLX040	SLX040
40 + 2 x 40*	Dual Output	MLX040	2 X SLX040
40 + 3 x 40*	Dual Output	MLX040	3 X SLX040
40 + 160*	Dual Output	MLX040	SLX160
80	Single Output	MLX080	None
80 + 40*	Dual Output	MLX080	SLX040
80 + 2 x 40*	Dual Output	MLX080	2 x SLX040
80 + 3 x 40*	Dual Output	MLX080	3 x SLX040
80 + 160*	Dual Output	MLX080	SLX160
120	Single Output	MLX120	None
120 + 40*	Dual Output	MLX120	SLX040
120 + 2 x 40*	Dual Output	MLX120	2 x SLX040
120 + 3 x 40*	Dual Output	MLX120	3 x SLX040
120 + 160*	Dual Output	MLX120	SLX160
160	Single Output	MLX160	None
320	Single Output	MLX160	SLX160
160 + 40	Dual Output	MLX160	SLX040
160 + 2 x 40*	Dual Output	MLX160	2 x SLX040
160 + 3 x 40*	Dual Output	MLX160	3 x SLX040
160 + 160*	Dual Output	MLX160	SLX160

* Verified by design as a building block of MLX160+SLX160. Test data not available for these individual combinations

Technical Specifications (continued)

Ordering Information

Please contact our Sales Representative for pricing, availability, and optional features.

Table 5. Device Codes

Device Code	Type	Input Voltage Range	Output Voltage	Output Current	On/Off Logic	Ordering code
SLX040A0XY3-SRZ	Satellite	7 – 14V _{DC}	0.45 – 2 V _{DC}	40A	Programmable	1600374229A*

* Pair with suitable MLX160/120/080/040 module as explained on previous page. Cannot be used without Master

Table 6. Coding Scheme

Module type Identifier	Family	Sequencing Option	Output current	Output voltage	On/Off logic	Remote Sense	Options	ROHS Compliance
S	L	X	040A0	X	Y	3	-SR	Z
M=master S=satellite	L = DLynx III	X=without sequencing	40A	X = programmable output	Y = programmable enable logic	3 = Remote Sense	S = Surface Mount R = Tape & Reel	Z = ROHS Compliant

Table 7 Orderable Accessories

Manufacturer Part Number	Ordering Code	Description
EVAl MLX160 SLX040 DUAL OUTPUT	1600374232A	Evaluation Board with MLX160A module AND 40A SLX module
DIGITAL_POL_EVAL_KIT	CC109164430	Digital Power Insights (DPI) it with USB dongle, needed cables, and a digital POL evaluation board (PDT012 or PJT020) and quick guide
I2C_USB_DONGLE_2.x	1600218857A	USB dongle required for use of Digital Power Insights software. Other contents of the DIGITAL_POL_EVAL_KIT are not included

ABB Power Electronics Inc.'s digital non-isolated DC-DC products may be covered by one or more of the following patents licensed from Bel Power Solutions, Inc.: US20040246754, US2004090219A1, US2004093533A1, US2004123164A1, US2004123167A1, US2004178780A1, US2004179382A1, US20050200344, US20050223252, US2005289373A1, US20060061214, US2006015616A1, US20060174145, US20070226526, US20070234095, US20070240000, US20080052551, US20080072080, US20080186006, US6741099, US6788036, US6936999, US6949916, US7000125, US7049798, US7068021, US7080265, US7249267, US7266709, US7315156, US7372682, US7373527, US7394445, US7456617, US7459892, US7493504, US7526660.

Outside the US Bel Power Solutions, Inc. licensed technology is protected by patents: AU3287379AA, AU3287437AA, AU3290643AA, AU3291357AA, CN10371856C, CN10452610C, CN10458656C, CN10459360C, CN10465848C, CN11069332A, CN11124619A, CN11346682A, CN1685299A, CN1685459A, CN1685582A, CN1685583A, CN1698023A, CN1802619A, EP1561156A1, EP1561268A2, EP1576710A1, EP1576711A1, EP1604254A4, EP1604264A4, EP1714369A2, EP1745536A4, EP1769382A4, EP1899789A2, EP1984801A2, W004044718A1, W004045042A3, W004045042C1, W004062061 A1, W004062062A1, W004070780A3, W004084390A3, W004084391A3, W005079227A3, W005081771A3, W006019569A3, W02007001584A3, W02007094935A3

Contact Us

For more information, call us at

USA/Canada:

+1 888 546 3243, or +1 972 244 9288

Asia-Pacific:

+86-21-53899666

Europe, Middle-East and Africa:

+49.89.878067-280

Change History (excludes grammar & clarifications)

Version	Date	Description of the change
1.4	6/ 27/ 2023	Updated Stencil Thickness



ABB
601 Shiloh Rd.
Plano, TX USA

abbpowerconversion.com

We reserve the right to make technical changes or modify the contents of this document without prior notice. With regard to purchase orders, the agreed particulars shall prevail. ABB does not accept any responsibility whatsoever for potential errors or possible lack of information in this document.

We reserve all rights in this document and in the subject matter and illustrations contained therein. Any reproduction, disclosure to third parties or utilization of its contents – in whole or in parts – is forbidden without prior written consent of ABB.

Copyright© 2021 ABB
All rights reserved.