

NOTES:

1. MATERIALS AND FINISHES:
 BODIES, OUTER CONTACT, CLAMP NUT, BRAID CLAMP, WASHER & COUPLING NUT - BRASS, NICKEL PLATING
 BULLET CONTACT - BRASS, SILVER PLATING
 CONTACT - BeCu, SILVER PLATING
 WASHER - COPPER, NICKEL PLATING
 INSULATORS - PTFE, NATURAL
 GASKETS - SILICONE RUBBER, RED
 RETAINING RING - PHOSPHOR BRONZE, NATURAL
2. ELECTRICAL:
 A. IMPEDANCE: 50 OHM
 B. FREQUENCY RANGE: DC - 11 GHz
3. MECHANICAL:
 A. DURABILITY: 500 CYCLES MIN.
 B. TEMPERATURE RANGE: -65° C TO +165° C

4. PACKAGING:
 A. QUANTITY: SINGLE PACK
 B. MARKING: BAG TO BE MARKED "AMPHENOL RF, 82-835, AND DATE CODE"
5. CABLE ASSEMBLY INSTRUCTIONS:
 A. STRIP CABLE AS SHOWN.
 B. SLIDE CLAMP NUT, WASHERS, GASKET & BRAID CLAMP OVER CABLE SHEATH.
 C. COMB OUT THE BRAID AND FOLD OUT, TRIM EXCESS BRAID.
 D. SOLDER CABLE CENTER CONDUCTOR TO CENTER CONTACT.
 E. SLIDE SUB-ASSEMBLY TO THE REAR SIDE OF THE BODY AND TIGHTEN WITH PROPER SPANNER. MAKE ENSURE INTERFACE DIMENSIONS TO MEET.

6 SHOWS CABLE ENTRY DIMENSIONS.

THIRD ANGLE PROJ.

REVISIONS

| REV | DESCRIPTION | DATE | ECO | APPR |
|-----|------------------------------------|-----------|-------|------|
| -- | RELEASE TO MFG. | -- | -- | -- |
| V | REDRAWN IN PRO-E & COD SHEET ADDED | 23-May-17 | 03863 | MB |

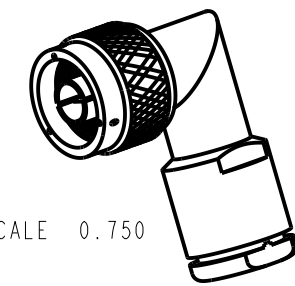

SCALE 0.750

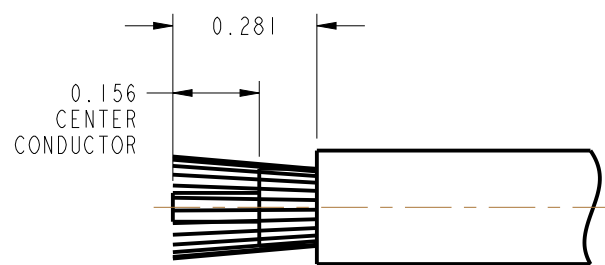
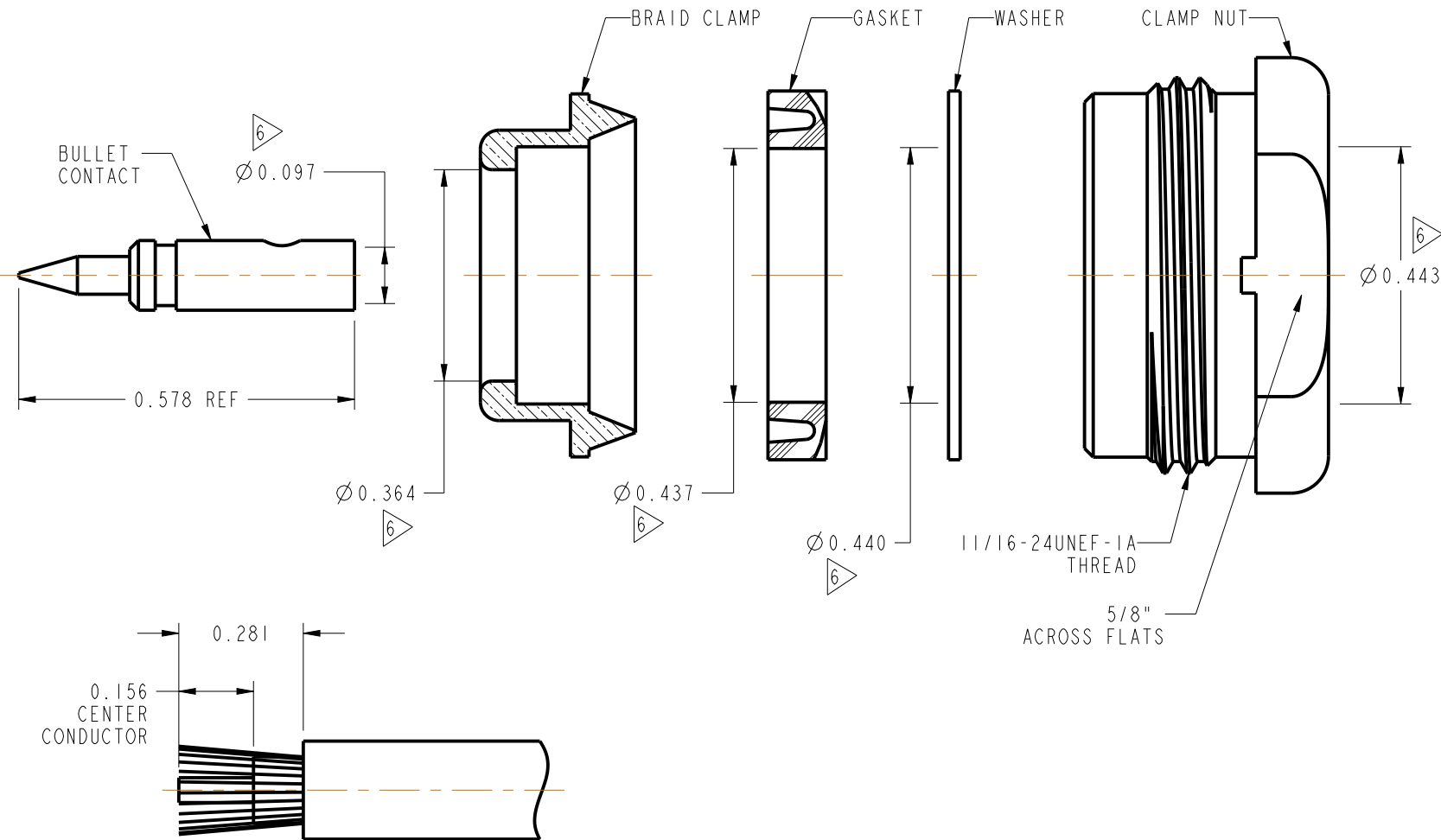
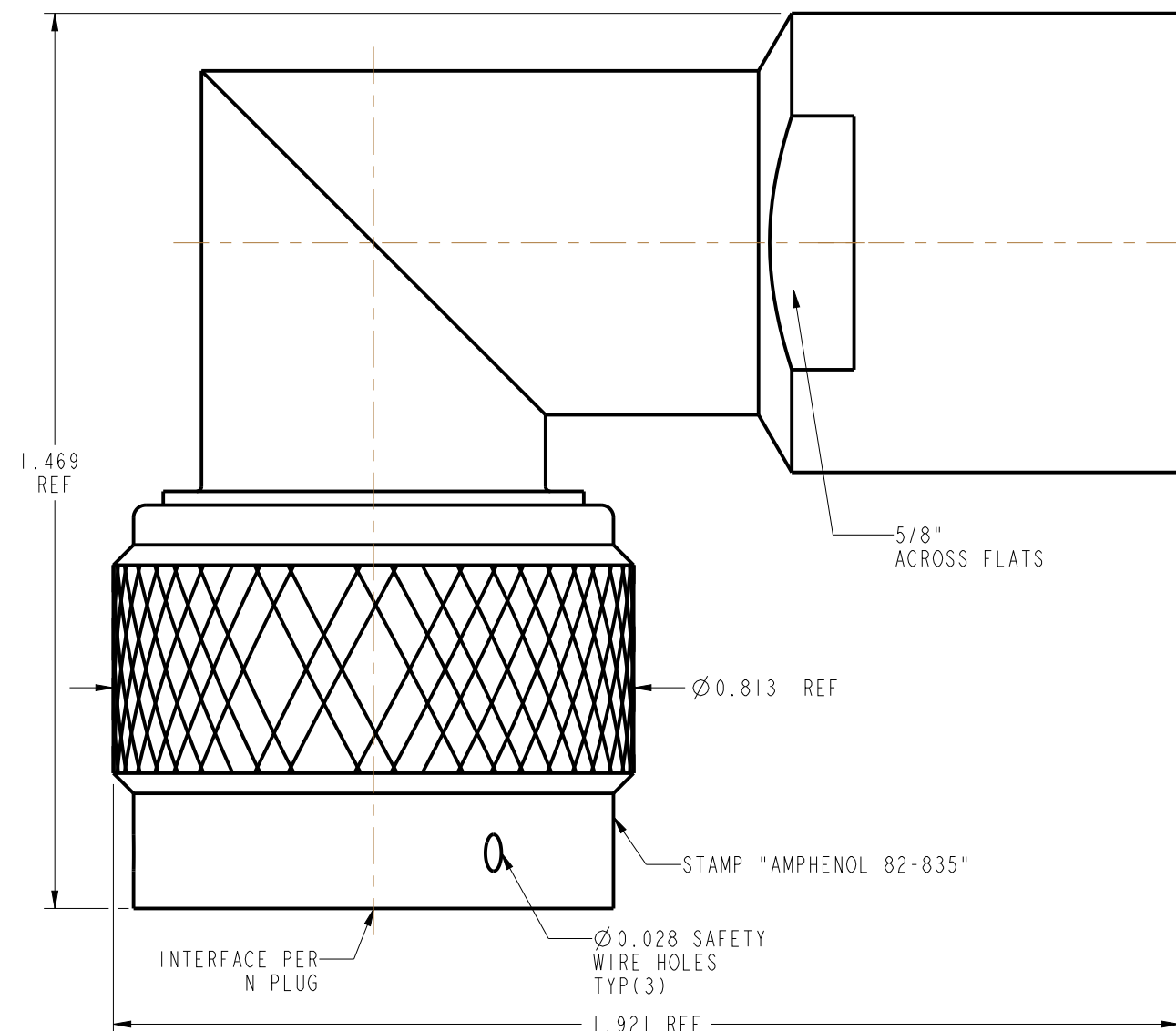

RECOMMENDED CABLE STRIPPING DIMENSIONS

CUSTOMER OUTLINE DRAWING
 ALL OTHER SHEETS ARE FOR INTERNAL USE ONLY

| | | | | | |
|---|------------------------------|------------|------------------|--|-----------------------------------|
| UNLESS OTHERWISE SPECIFIED, DIMENSIONS ARE IN INCHES AND TOLERANCES ARE: 2 PLACE DECIMAL 3 PLACE DECIMAL ±.015 (0,381 mm) ±.005 (0,127 mm) | MATERIAL | DRAWN | DATE | TITLE TYPE N RIGHT ANGLE PLUG FOR RG-8/U, 9/U, 213/U, 214/U & 225/U CABLE | Amphenol RF www.amphenolrf.com |
| | SEE NOTES | MOHAN | 04-Mar-14 | | |
| NOTICE - These drawings, specifications, or other data (1) are, and remain the property of Amphenol corp. (2) must be returned upon request; and (3) are confidential and not to be disclosed to any person other than those to whom they are given by Amphenol Corp. the furnishing of these drawings, specifications, or other data by Amphenol Corp., or to any other person for any purpose is not to be regarded by implication or otherwise in any manner licensing, granting rights to permitting such holder or any other person to manufacture, use or sell any product, process or design, patented or otherwise, that may in any way be related to or disclosed by said drawings, specifications, or other data. | REFERENCE | ENGINEER | DATE | DRAWING NO. 82-835 ITEM NO. 82-835 | |
| | EAR # | K. CAPOZZI | 04-Mar-14 | | |
| | CONFIGURATION LEVEL: In Work | APPROVED | DATE | SCALE: 3.5:1.0 SHEET 2 OF 2 | PART NO. 82-835 |
| FINISH | K. CAPOZZI | 23-May-17 | DWG SIZE B REV V | | |