



BNC Twinax Plug Connector Crimp/Solder Attachment for RG108, 78 Ohm Twinax

RF Connectors Technical Data Sheet

PE4234

Configuration

- BNC Twinax Plug Connector
- MIL-STD-348A
- 78 Ohms
- Straight Body Geometry
- Connector Interface Types: RG108, 78 Ohm Twinax

Features

- Max. Operating Frequency 500 MHz
- Gold Plated Brass/Beryllium Copper Contact
- 30 μ m minimum contact plating

Applications

- General Purpose Test
- Custom Cable Assemblies

Description

Pasternack's PE4234 , BNC Twinax, Standard, Connector is part of our full line of RF components available for same-day shipping. Our BNC Twinax plug connector operates up to a maximum frequency of 500 MHz.

Our 78 ohm BNC Twinax plug connector PE4234 datasheet specifications and drawing with dimensions are shown below in this PDF. Pasternack's broad catalog of RF, microwave and millimeter wave connectors allows designers to configure and customize their signal connections however they like. Whether the need is to provide an I/O for a board design, or simply create a custom cable assembly configuration, Pasternack has the right connector for the job. Pasternack can also expertly build your custom cable assemblies for you and ship same-day.

Electrical Specifications

Description	Minimum	Typical	Maximum	Units
Frequency Range	DC		500	MHz
Operating Voltage (AC)			500	Vrms
Impedance		78		Ohms

Mechanical Specifications

Size	
Length	1.52 in [38.66 mm]
Width	0.57 in [14.50 mm]
Weight	0.05 lbs [20.41 g]

Click the following link (or enter part number in "SEARCH" on website) to obtain additional part information including price, inventory and certifications: [BNC Twinax Plug Connector Crimp/Solder Attachment for RG108, 78 Ohm Twinax PE4234](#)



BNC Twinax Plug Connector Crimp/Solder Attachment for RG108, 78 Ohm Twinax

RF Connectors Technical Data Sheet

PE4234

Material Specifications

Description	Material	Plating
Contact	Brass/Beryllium Copper	Gold 30 µin minimum
Insulation	PTFE	
Body	Brass	Nickel 100 µin minimum
Coupling Nut	Brass	Nickel 100 µin minimum
Gasket	Silicone	
Crimp Sleeve	Brass	Nickel
Washer	Brass	Nickel

Environmental Specifications

Temperature

Operating Range -65 to +165 deg C

Compliance Certifications (see [product page](#) for current document)

Plotted and Other Data

Notes:

BNC Twinax Plug Connector Crimp/Solder Attachment for RG108, 78 Ohm Twinax from Pasternack Enterprises has same day shipment for domestic and International orders. Our RF, microwave and millimeter wave products maintain a 99.4% availability and are part of the broadest selection in the industry.

Click the following link (or enter part number in "SEARCH" on website) to obtain additional part information including price, inventory and certifications: [BNC Twinax Plug Connector Crimp/Solder Attachment for RG108, 78 Ohm Twinax PE4234](#)

URL: <https://www.pasternack.com/bnc-twinax-plug-standard-rg108-78-ohm-twinax-connector-pe4234-p.aspx>

The information contained in this document is accurate to the best of our knowledge and representative of the part described herein. It may be necessary to make modifications to the part and/or the documentation of the part, in order to implement improvements. Pasternack reserves the right to make such changes as required. Unless otherwise stated, all specifications are nominal. Pasternack does not make any representation or warranty regarding the suitability of the part described herein for any particular purpose, and Pasternack does not assume any liability arising out of the use of any part or documentation.

PE4234 CAD Drawing

BNC Twinax Plug Connector Crimp/Solder Attachment for RG108, 78 Ohm Twinax

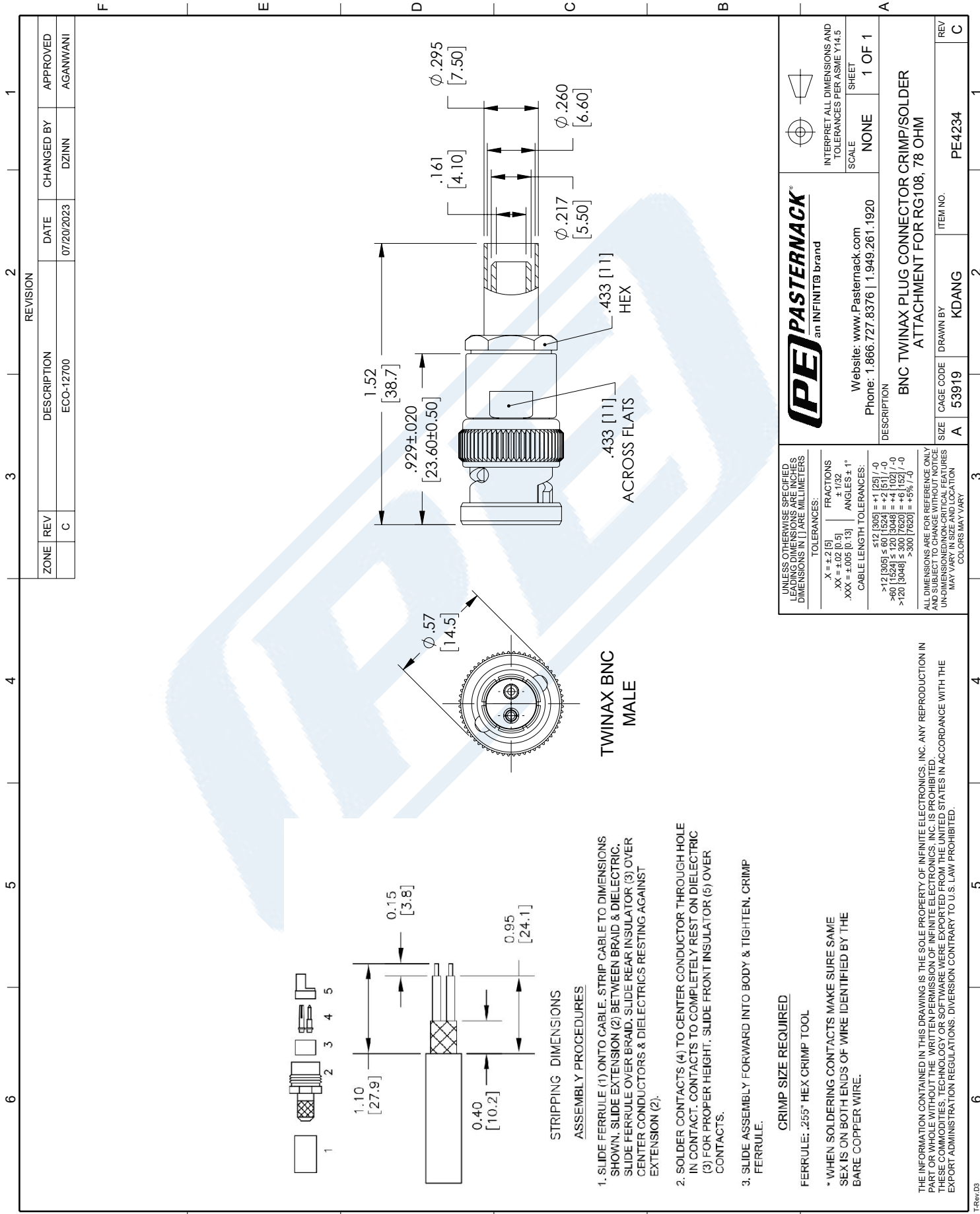

REVISION		DATE	CHANGED BY	APPROVED	
ZONE	REV	DESCRIPTION	ECO-12700	DZINN	AGANWANI
	C				

PASTERNAK an INFINIT® brand		INTERPRET ALL DIMENSIONS AND TOLERANCES PER ASME Y14.5 SCALE: NONE SHEET: 1 OF 1
Website: www.Pasternack.com Phone: 1.866.727.8376 1.949.261.1920		DESCRIPTION: BNC TWINAX PLUG CONNECTOR CRIMP/SOLDER ATTACHMENT FOR RG108, 78 OHM
SIZE: A	CAGE CODE: 53919	DRAWN BY: KDANG
ITEM NO.: PE4234		REV: C

UNLESS OTHERWISE SPECIFIED LEADING DIMENSIONS ARE INCHES DIMENSIONS IN [] ARE MILLIMETERS

TOLERANCES:

.X = ±.2 [5] FRACTIONS
 .XX = ±.02 [0.5] ± 1/32
 .XXX = ±.005 [0.13] ANGLES ± 1°

CABLE LENGTH TOLERANCES:

<12 [305] ≤ +1 [25] / -0
 >12 [305] ≤ 60 [1524] = +2 [51] / -0
 >60 [1524] ≤ 120 [3048] = +4 [102] / -0
 >120 [3048] ≤ 300 [7620] = +6 [152] / -0
 >300 [7620] = +8% / -0

ALL DIMENSIONS ARE FOR REFERENCE ONLY AND SUBJECT TO CHANGE WITHOUT NOTICE UNLESS INDICATED OTHERWISE. DIMENSIONS MAY VARY IN SIZE AND LOCATION COLORS MAY VARY

THE INFORMATION CONTAINED IN THIS DRAWING IS THE SOLE PROPERTY OF INFINITE ELECTRONICS, INC. ANY REPRODUCTION IN PART OR WHOLE WITHOUT THE WRITTEN PERMISSION OF INFINITE ELECTRONICS, INC. IS PROHIBITED. THESE COMMODITIES, TECHNOLOGY OR SOFTWARE WERE EXPORTED FROM THE UNITED STATES IN ACCORDANCE WITH THE EXPORT ADMINISTRATION REGULATIONS. DIVERSION CONTRARY TO U.S. LAW PROHIBITED.