

Symbol

PRODUCT CHARACTERISTICS

VDSS	650V
R _{DS(on)} Typ(@V _{GS} =10V)	1.1Ω
Qg@type	29nC
ID	7A

APPLICATIONS

- High efficiency switch mode power supplies
- Electronic lamp ballasts based on half bridge
- LED power supplies

FEATURES

- * Ultra low gate charge
- * Low reverse transfer Capacitance
- * Fast switching capability
- * Avalanche energy tested
- * Improved dv/dt capability, high ruggedness

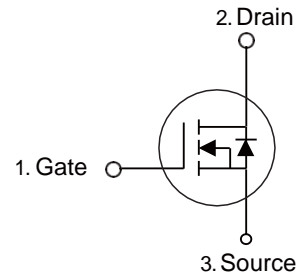

ORDER INFORMATION

Order codes		Package	Packing
Halogen-Free	Halogen		
N/A	MOT7N65AF	TO-220F	50 pieces/Tube
N/A	MOT7N65A	TO-220	50 pieces/Tube

ABSOLUTE MAXIMUM RATINGS (T_c = 25°C, unless otherwise specified)

PARAMETER	SYMBOL	RATINGS	UNIT
Drain-Source Voltage	V _{DSS}	650	V
Gate-Source Voltage	V _{GSS}	±30	V
Avalanche Current (Note 2)	I _{AR}	7	A
Drain Current	Continuous	I _D	7
	Pulsed (Note 2)	I _{DM}	29.6
Avalanche Energy	Single Pulsed (Note 3)	E _{AS}	530
	Repetitive (Note 2)	E _{AR}	14.2
Peak Diode Recovery dv/dt (Note 4)	dv/dt	4.5	V/ns
Power Dissipation	TO-220	P _D	142
	TO-220F		48
Junction Temperature	T _J	+150	°C
Storage Temperature	T _{STG}	-55 ~ +150	°C

Notes: 1. Absolute maximum ratings are those values beyond which the device could be permanently damaged.

Absolute maximum ratings are stress ratings only and functional device operation is not implied.

2. Repetitive Rating : Pulse width limited by maximum junction temperature
3. L = 19.5mH, I_{AS} = 7A, V_{DD} = 50V, R_G = 25 Ω, Starting T_J = 25°C
4. I_{SD} ≤ 7A, di/dt ≤ 200A/μs, V_{DD} ≤ BV_{DSS}, Starting T_J = 25°C

■ ELECTRICAL CHARACTERISTICS ($T_C=25^\circ\text{C}$, unless otherwise specified)

PARAMETER	SYMBOL	TEST CONDITIONS	MIN	TYP	MAX	UNIT
Drain-Source Breakdown Voltage	BV_{DSS}	$V_{GS} = 0V, I_D = 250\mu A$	650	-	-	V
Drain-Source Leakage Current	I_{DSS}	$V_{DS} = 650V, V_{GS} = 0V$	-	-	1	μA
Gate- Source Leakage Current	Forward	I_{GSS} $V_{GS} = 30V, V_{DS} = 0V$ $V_{GS} = -30V, V_{DS} = 0V$	-	-	100	nA
	Reverse		-	-	-100	nA
Breakdown Voltage Temperature Coefficient	$\Delta BV_{DSS}/\Delta T_J$	$I_D=250\mu A, \text{Referenced to } 25^\circ\text{C}$	-	0.67	-	$V/^\circ\text{C}$
On characteristics						
Gate Threshold Voltage	$V_{GS(TH)}$	$V_{DS} = V_{GS}, I_D = 250\mu A$	2.0	-	4.0	V
Static Drain-Source On-State Resistance	$R_{DS(ON)}$	$V_{GS} = 10V, I_D = 3.5A$	-	1.1	1.2	Ω
Dynamic characteristics						
Input Capacitance	C_{ISS}	$V_{DS}=25V, V_{GS}=0V,$ $f=1.0\text{ MHz}$	-	1400	-	pF
Output Capacitance	C_{OSS}		-	180	-	pF
Reverse Transfer Capacitance	C_{RSS}		-	16	-	pF
Switching characteristics						
Turn-On Delay Time	$t_{D(ON)}$	$V_{DD}=325V, I_D=7.4A,$ $R_G=25\Omega \text{ (Note 1, 2)}$	-	70	-	ns
Turn-On Rise Time	t_R		-	170	-	ns
Turn-Off Delay Time	$t_{D(OFF)}$		-	140	-	ns
Turn-Off Fall Time	t_F		-	130	-	ns
Switching characteristics						
Total Gate Charge	Q_G	$V_{DS}=520V, I_D=7A,$ $V_{GS}=10\text{ V (Note 1, 2)}$	-	29	-	nC
Gate-Source Charge	Q_{GS}		-	7	-	nC
Gate-Drain Charge	Q_{GD}		-	14.5	-	nC
Drain-source diode characteristics and maximum ratings						
Drain-Source Diode Forward Voltage	V_{SD}	$V_{GS} = 0V, I_S = 7A$	-	-	1.4	V
Maximum Continuous Drain-Source Diode Forward Current	I_S		-	-	7	A
Maximum Pulsed Drain-Source Diode Forward Current	I_{SM}		-	-	29.6	A
Reverse Recovery Time	t_{rr}	$V_{GS} = 0V, I_S = 7A,$	-	320	-	ns
Reverse Recovery Charge	Q_{RR}	$dI_F / dt = 100A/\mu s \text{ (Note 1)}$	-	2.4	-	μC

Notes: 1. Pulse Test: Pulse width $\leq 300\mu s$, Duty cycle $\leq 2\%$

2. Essentially independent of operating temperature

■ TEST CIRCUITS AND WAVEFORMS

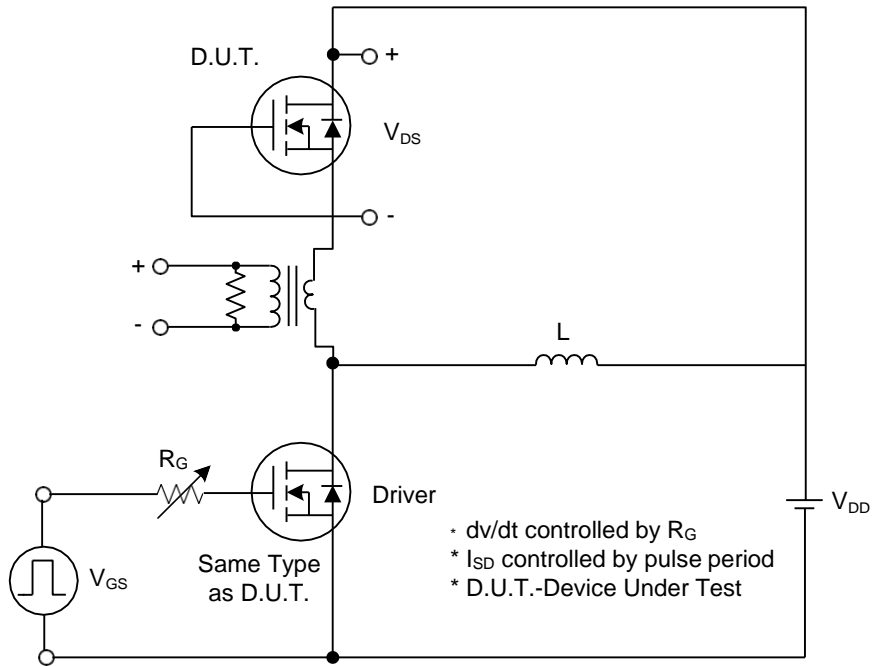

Peak Diode Recovery dv/dt Test Circuit

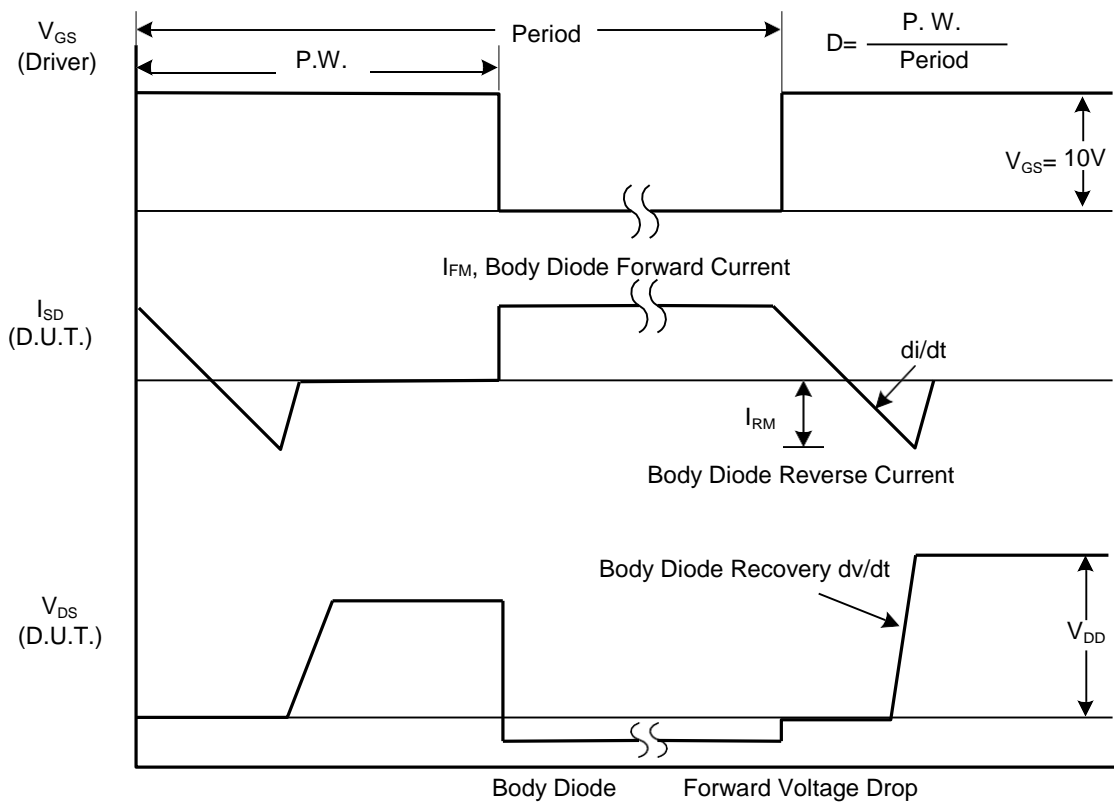

Peak Diode Recovery dv/dt Waveforms

■ TEST CIRCUITS AND WAVEFORMS(Cont.)

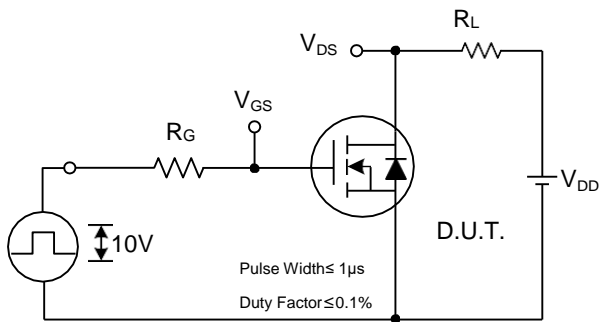

Switching Test Circuit

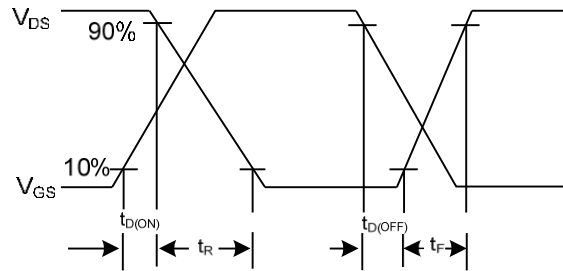

Switching Waveforms

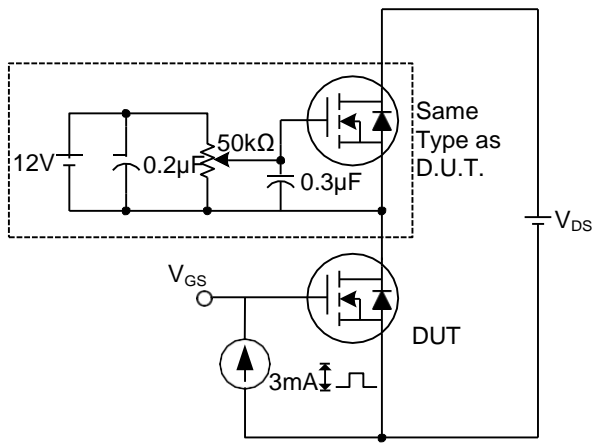

Gate Charge Test Circuit

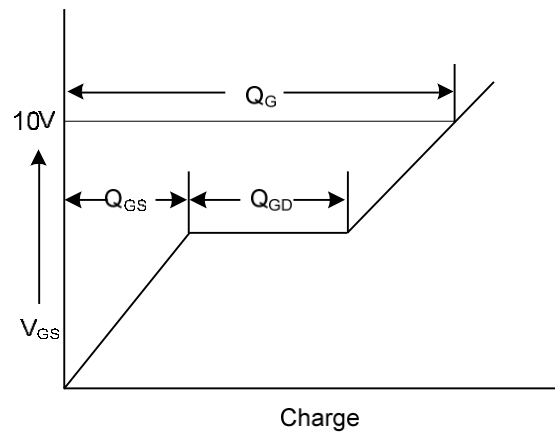

Gate Charge Waveform

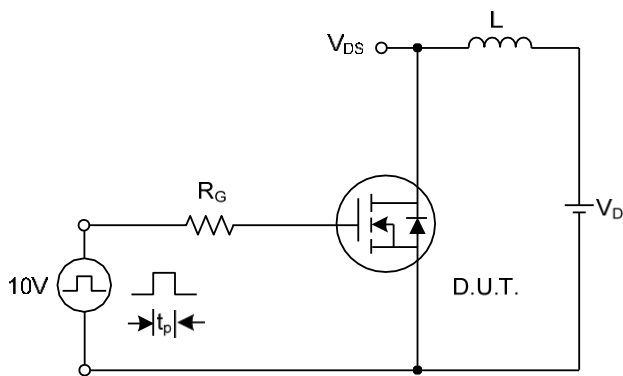

Unclamped Inductive Switching Test Circuit

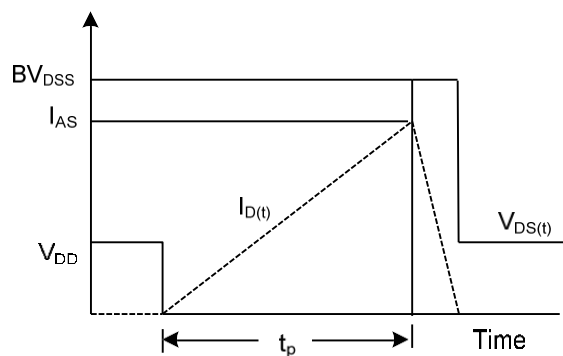

Unclamped Inductive Switching Waveforms

■ ELECTRICAL CHARACTERISTICS

On-Region Characteristics

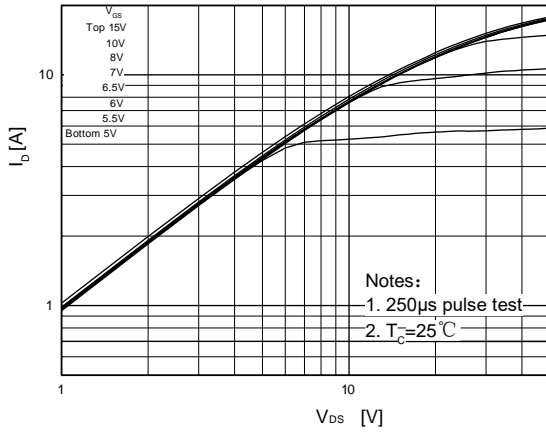

Transfer Characteristics

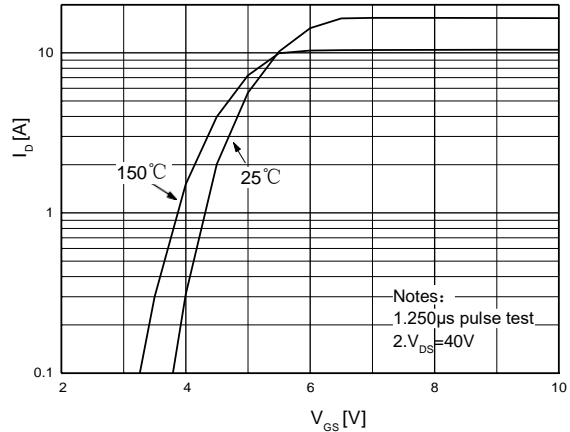

On-Resistance Variation vs. Drain Current and Gate Voltage

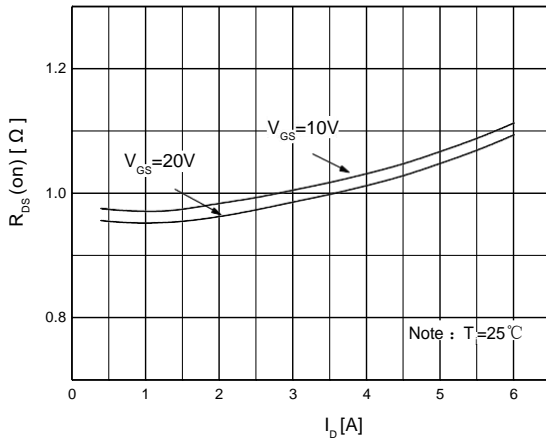

Body Diode Forward Voltage Variation vs. Source Current and Temperature

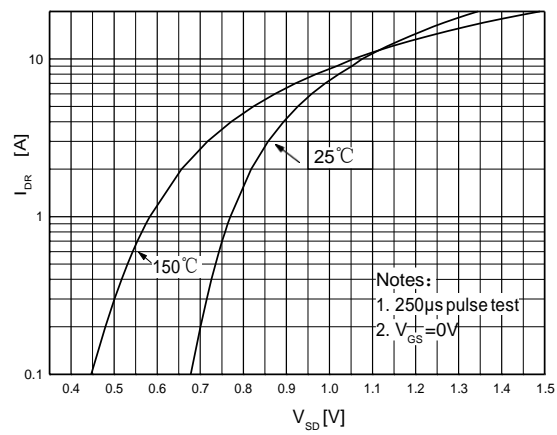

Capacitance Characteristics

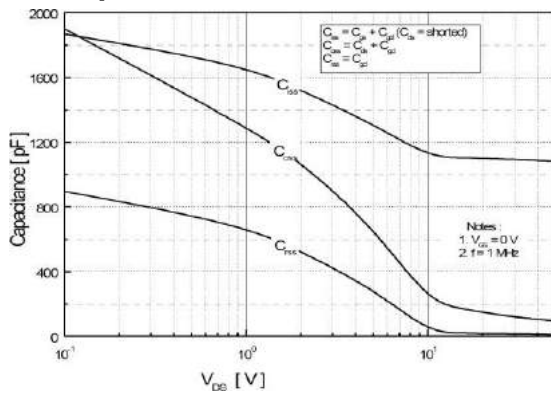

Gate Charge Characteristics

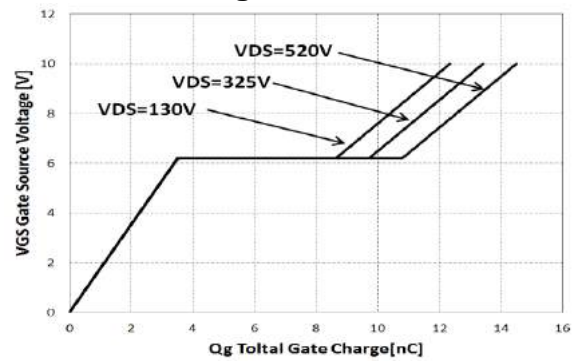

Breakdown Voltage Variation vs. Temperature

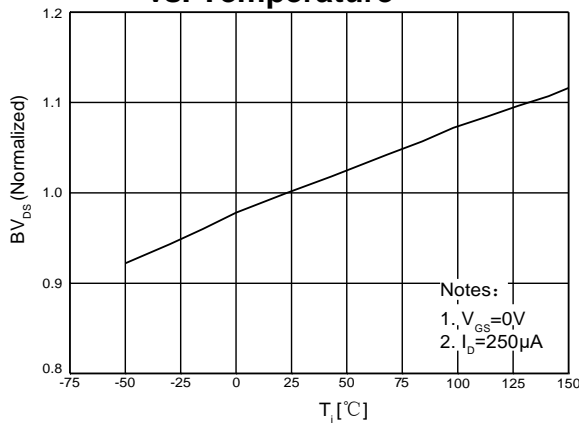

On-Resistance Variation vs. Temperature

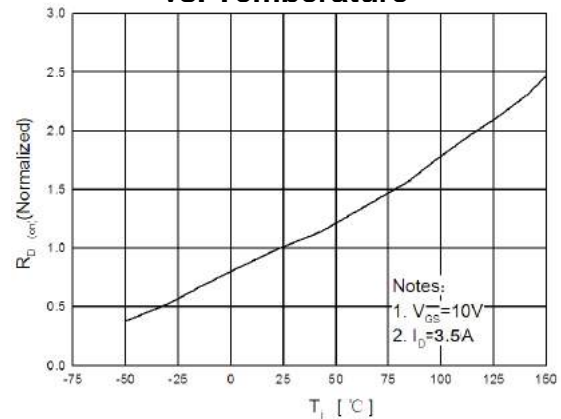

■ TO-220F-3L PACKAGE OUTLINE DIMENSIONS

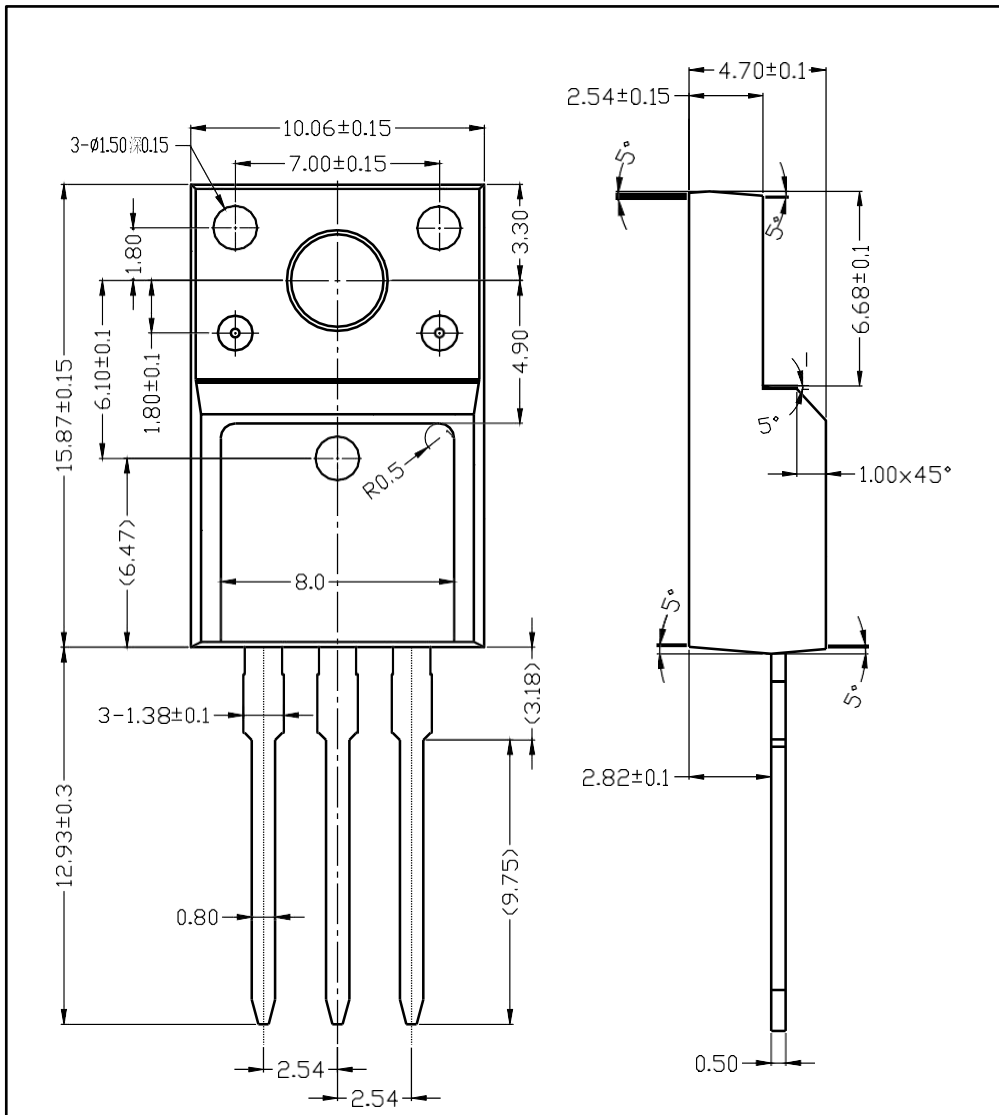

■ TO-220-3L PACKAGE OUTLINE DIMENSIONS

