

■ PRODUCT CHARACTERISTICS

VDSS	650V
$R_{DS(on)Typ}@V_{GS}=10V$	0.33Ω
Qg@type	4.8nC
ID	11A

■ APPLICATIONS

- \* Power factor correction
- \* Switched mode power supplies
- \* Uninterruptible power supply

■ FEATURES

- \* low  $R_{DS(on)}$
- \* low gate charge
- \* 100% UIS tested
- \* RoHS compliant

■ ORDER INFORMATION

Order codes		Package	Packing
Halogen-Free	Halogen		
N/A	MOT65R380F	TO-220F	50 pieces/Tube
N/A	MOT65R380A	TO-220	50 pieces/Tube

■ ABSOLUTE MAXIMUM RATINGS ( $T_c=25^\circ\text{C}$  unless otherwise specified)

Parameter	Symbol	Value	Unit
Drain-Source Voltage	$V_{DSS}$	650	V
Continuous drain current	$I_D$	11	A
Pulsed drain current	$I_{DM}$	30	A
Gate-Source voltage	$V_{GSS}$	$\pm 30$	V
Avalanche energy, single pulse	$E_{AS}$	245	mJ
Avalanche current, repetitive <sup>3)</sup>	$I_{AR}$	11	A
Power Dissipation TO-220	$P_D$	90	W
Power Dissipation TO-220F		31.8	W
Operating and Storage Temperature Range	$T_J, T_{STG}$	-55 to +150	$^\circ\text{C}$
Continuous diode forward current	$I_S$	11	A
Diode pulse current	$I_{S,pulse}$	30	A

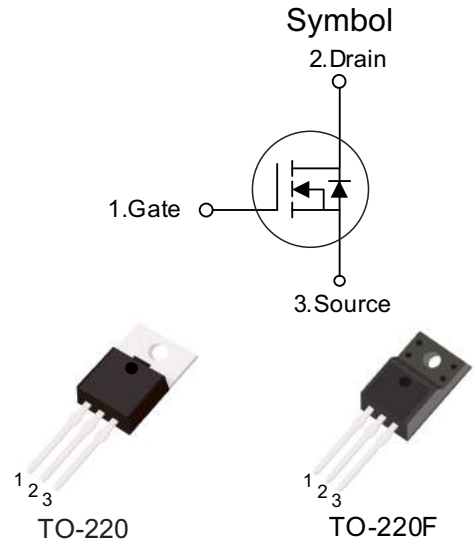

**■ ELECTRICAL CHARACTERISTICS (T<sub>J</sub> =25°C, unless otherwise specified)**

Parameter	Symbol	Test Condition	Min.	Typ.	Max.	Unit
<b>Static characteristics</b>						
Drain-source breakdown voltage	BV <sub>DSS</sub>	V <sub>GS</sub> =0 V, I <sub>D</sub> =0.25 mA	650	-	-	V
Gate threshold voltage	V <sub>GS(th)</sub>	V <sub>DS</sub> =V <sub>GS</sub> , I <sub>D</sub> =0.25mA	2.5	3.5	4.5	V
Drain cut-off current	I <sub>DSS</sub>	V <sub>DS</sub> =650 V, V <sub>GS</sub> =0 V, T <sub>J</sub> = 25°C	-	-	1	μA
		T <sub>J</sub> = 125°C	-	10	-	μA
Gate leakage current, Forward	I <sub>GSSF</sub>	V <sub>GS</sub> =30 V, V <sub>DS</sub> =0 V	-	-	100	nA
Gate leakage current, Reverse	I <sub>GSSR</sub>	V <sub>GS</sub> =-30 V, V <sub>DS</sub> =0 V	-	-	-100	nA
Drain-source on-state resistance	R <sub>DS(on)</sub>	V <sub>GS</sub> =10 V, I <sub>D</sub> =5.5 A T <sub>J</sub> = 25°C	-	0.33	0.38	Ω
		T <sub>J</sub> = 150°C	-	0.9	-	Ω
Gate resistance	R <sub>G</sub>	f=1 MHz, open drain	-	5.7	-	Ω
<b>Dynamic characteristics</b>						
Input capacitance	C <sub>iss</sub>	V <sub>DS</sub> = 25 V, V <sub>GS</sub> = 0 V, f = 1 MHz	-	560	-	pF
Output capacitance	C <sub>oss</sub>		-	216	-	pF
Reverse transfer capacitance	C <sub>rss</sub>		-	1.2	-	pF
Turn-on delay time	t <sub>d(on)</sub>	V <sub>DD</sub> = 400V, I <sub>D</sub> = 5.5A R <sub>G</sub> = 10Ω, V <sub>GS</sub> =15V	-	20.6	-	ns
Rise time	t <sub>r</sub>		-	32	-	ns
Turn-off delay time	t <sub>d(off)</sub>		-	62	-	ns
Fall time	t <sub>f</sub>		-	12.5	-	ns
<b>Gate charge characteristics</b>						
Gate to source charge	Q <sub>gs</sub>	V <sub>DD</sub> =400 V, I <sub>D</sub> =5.5A, V <sub>GS</sub> =0 to 10 V	-	4.8	-	nC
Gate to drain charge	Q <sub>gd</sub>		-	4.7	-	nC
Gate charge total	Q <sub>g</sub>		-	14.7	-	nC
Gate plateau voltage	V <sub>plateau</sub>		-	6	-	V
<b>Reverse diode characteristics</b>						
Diode forward voltage	V <sub>SD</sub>	V <sub>GS</sub> =0 V, I <sub>F</sub> =5.5A	-	1.2	-	V
Reverse recovery time	t <sub>rr</sub>	V <sub>R</sub> =400 V, I <sub>F</sub> =5.5A, di/dt=100 A/μs	-	234	-	ns
Reverse recovery charge	Q <sub>rr</sub>		-	4.4	-	μC
Peak reverse recovery current	I <sub>rrm</sub>		-	18.7	-	A

**Notes:**

- Limited by maximum junction temperature, maximum duty cycle is 0.75.
- I<sub>AS</sub> = 3A, V<sub>DD</sub> = 60V, Starting T<sub>J</sub>= 25°C.
- Repetitive Rating: Pulse width limited by maximum junction temperature.

■ ELECTRICAL CHARACTERISTICS DIAGRAMS

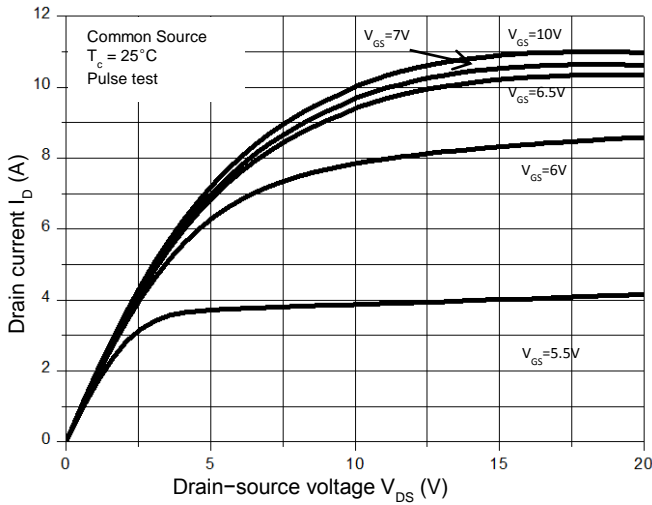

Figure 1. On-Region Characteristics

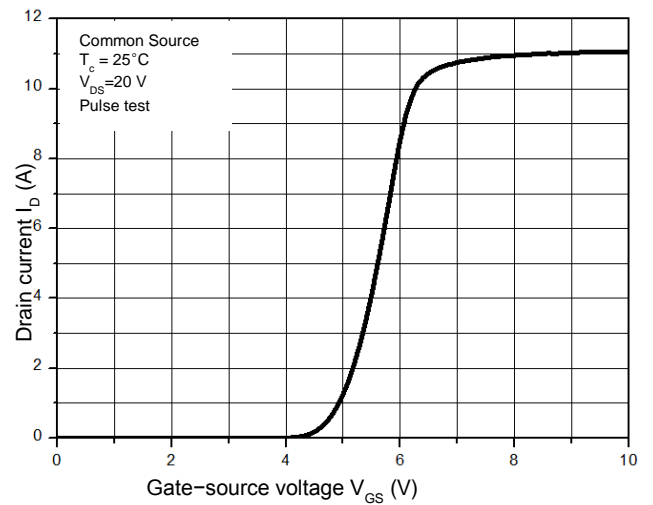

Figure 2. Transfer Characteristics

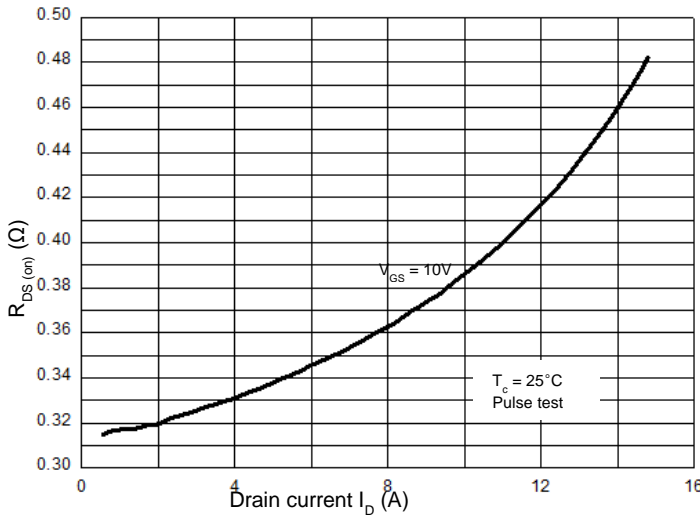

Figure 3. On-Resistance Variation vs. Drain Current

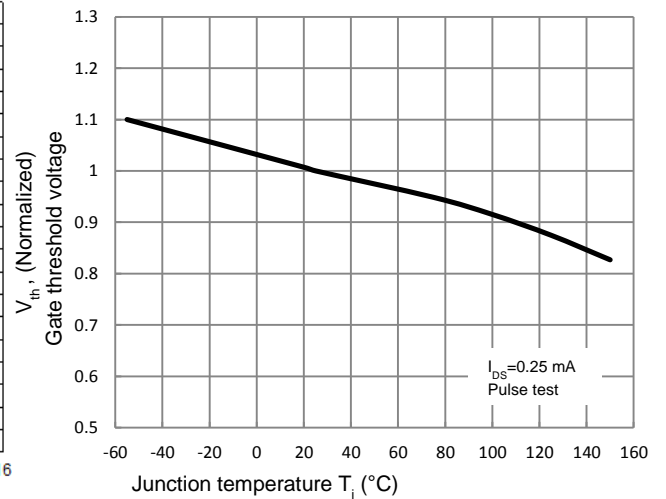

Figure 4. Threshold Voltage vs. Temperature

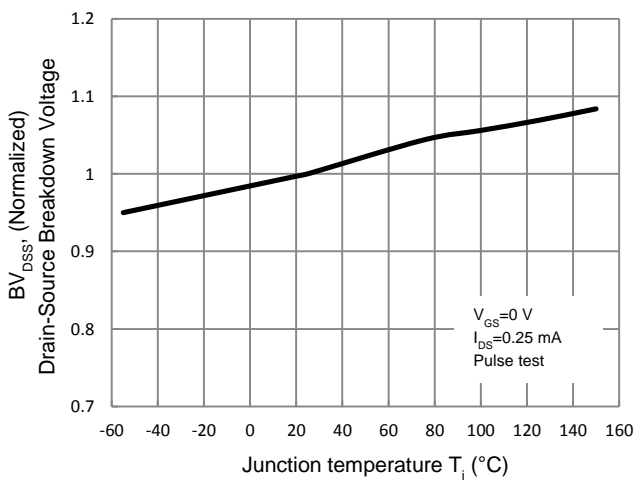

Figure 5. Breakdown Voltage vs. Temperature

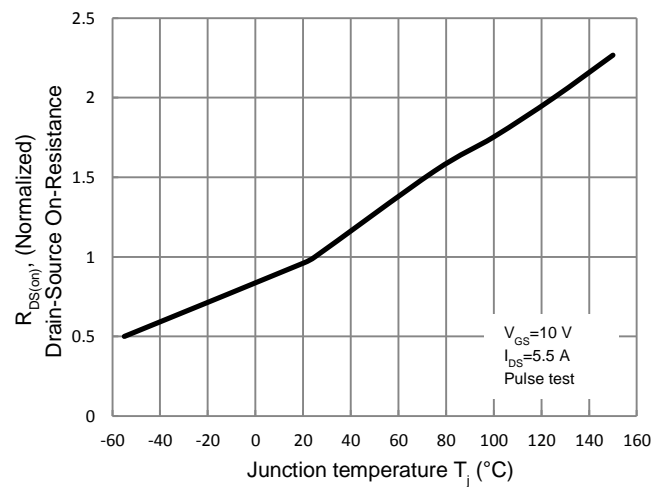

Figure 6. On-Resistance vs. Temperature

■ ELECTRICAL CHARACTERISTICS DIAGRAMS(Cont.)

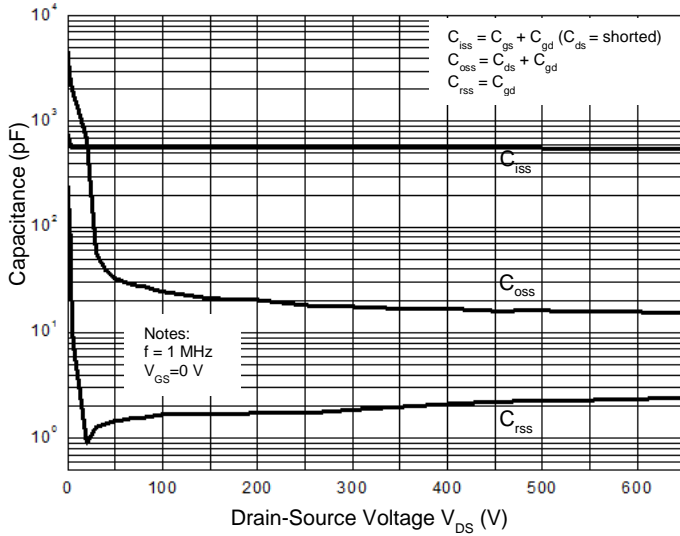

Figure 7. Capacitance Characteristics

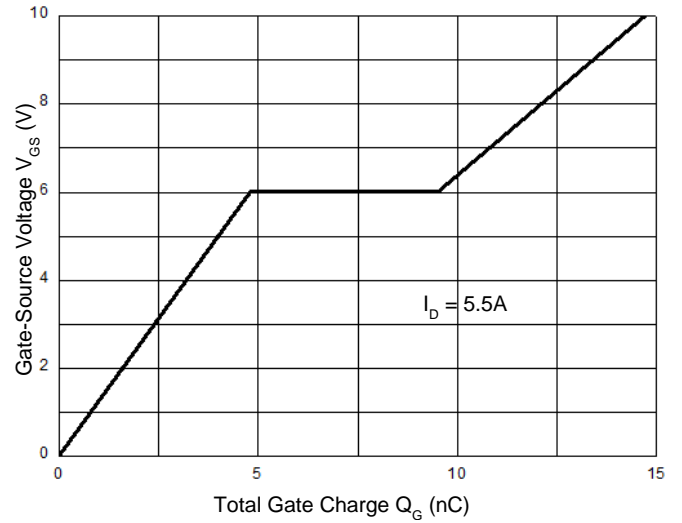

Figure 8. Gate Charge Characteristic

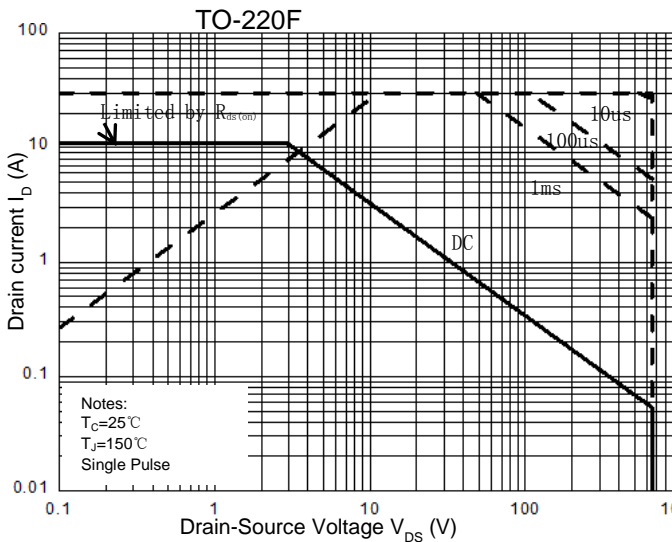

Figure 9.1 Maximum Safe Operating Area

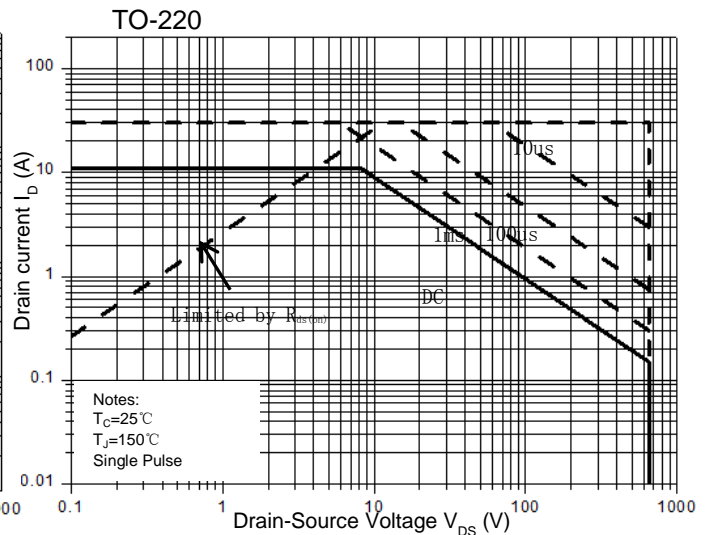

Figure 9.2 Maximum Safe Operating Area

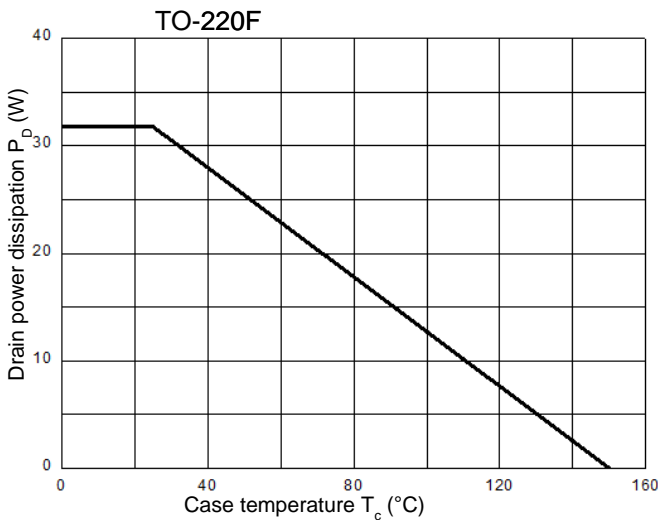

Figure 10.1 Power Dissipation vs. Temperature

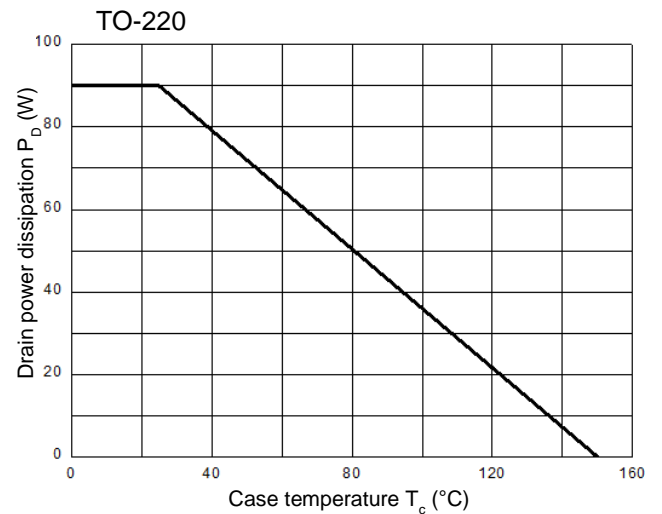
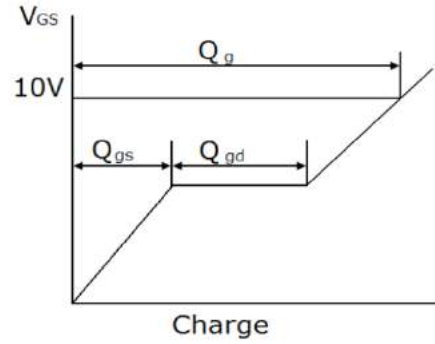
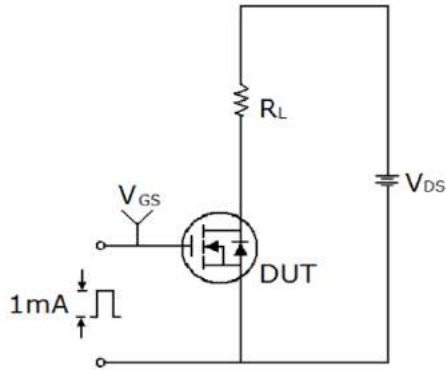
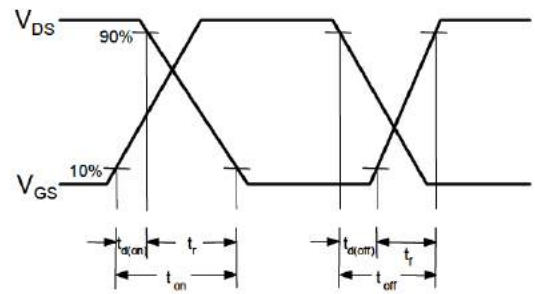
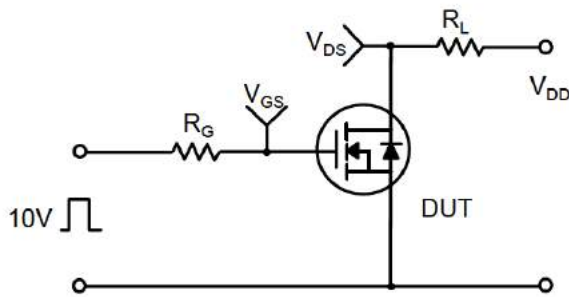

Figure 10.2 Power Dissipation vs. Temperature

■ TEST CIRCUITS AND WAVEFORMS



Switching Test Circuit & Waveforms



Unclamped Inductive Switching Test Circuit & Waveforms

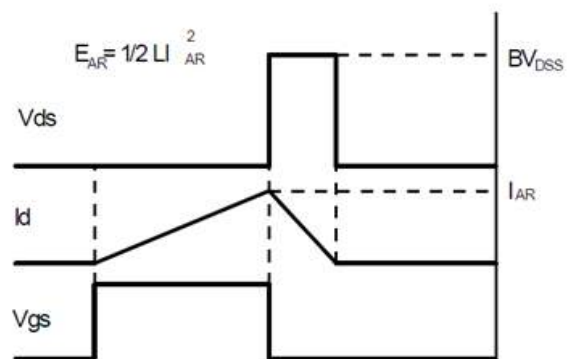
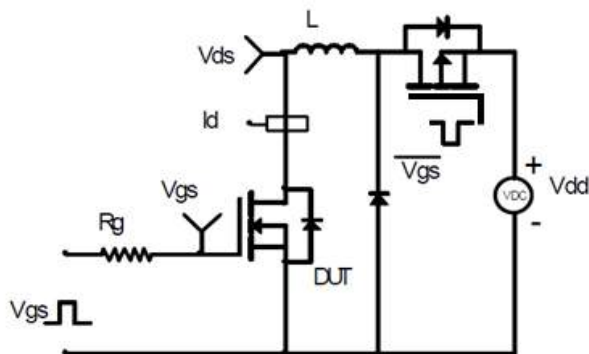

■ TO-220F PACKAGE OUTLINE DIMENSIONS

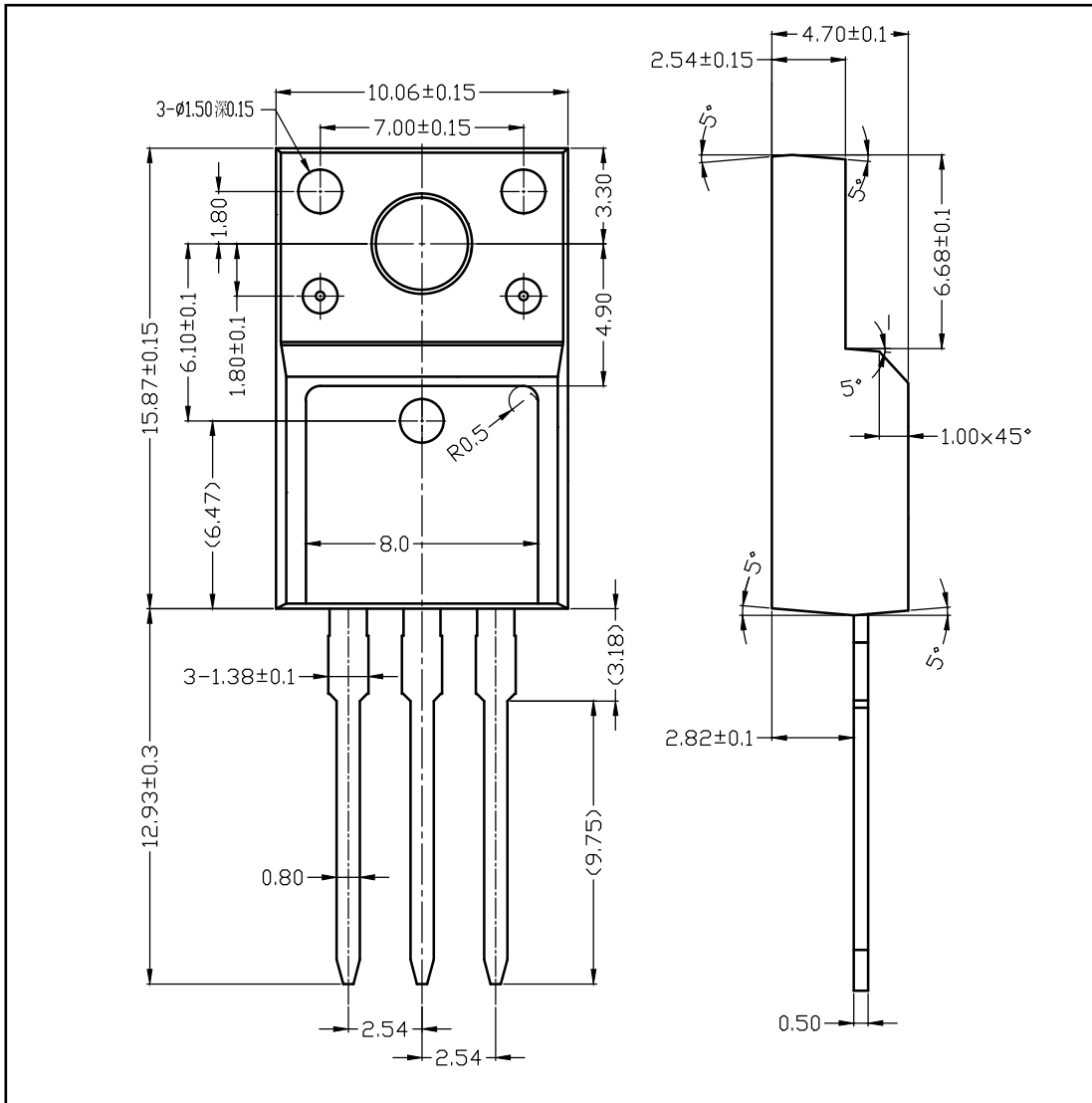

■ TO-220-3L PACKAGE OUTLINE DIMENSIONS

