

■ PRODUCT CHARACTERISTICS

VDSS	650V
$R_{DS(on)typ}(@_{V_{GS}}=10V)$	0.4Ω
Qg@type	54nC
ID	20A

Symbol

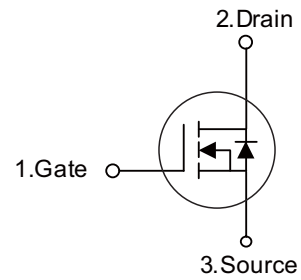

■ APPLICATIONS

- High efficiency switch mode power supplies
- Electronic ballasts
- LED power supply

■ FEATURES

- * High Switching Speed
- * 100% Avalanche Tested

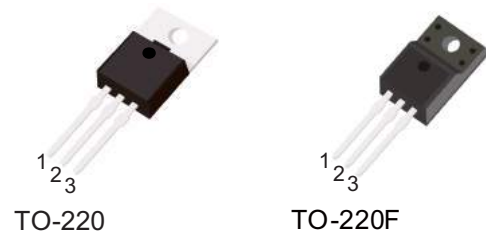

■ ORDER INFORMATION

Order codes		Package	Packing
Halogen-Free	Halogen		
N/A	MOT20N65HF	TO-220F	50 pieces/Tube
N/A	MOT20N65A	TO-220	50 pieces/Tube

■ ABSOLUTE MAXIMUM RATINGS ($T_C = 25^\circ\text{C}$, unless otherwise specified)

PARAMETER	SYMBOL	RATINGS	UNIT
Drain-Source Voltage	V_{DSS}	650	V
Gate-Source Voltage	V_{GSS}	±30	V
Drain Current	Continuous	I_D	20
	Pulsed (Note 2)	I_{DM}	40
Avalanche Energy	Single Pulsed (Note 3)	E_{AS}	562
Peak Diode Recovery dv/dt (Note 4)	dv/dt	2.46	V/ns
Power Dissipation	TO-220	P_D	270
	TO-220F		65
Junction Temperature	T_J	+150	°C
Storage Temperature	T_{STG}	-55 ~ +150	°C

Notes: 1. Absolute maximum ratings are those values beyond which the device could be permanently damaged.

Absolute maximum ratings are stress ratings only and functional device operation is not implied.

2. Repetitive Rating: Pulse width limited by maximum junction temperature.
3. $L = 10\text{mH}$, $I_{AS} = 10.5\text{A}$, $V_{DD} = 50\text{V}$, $R_G = 25\ \Omega$ Starting $T_J = 25^\circ\text{C}$
4. $I_{SD} \leq 20\text{A}$, $di/dt \leq 200\text{A}/\mu\text{s}$, $V_{DD} \leq BV_{DSS}$, Starting $T_J = 25^\circ\text{C}$

■ ELECTRICAL CHARACTERISTICS (T_C=25°C, unless otherwise noted)

PARAMETER		SYMBOL	TEST CONDITIONS	MIN	TYP	MAX	UNIT
Off characteristics							
Drain-Source Breakdown Voltage		BV _{DSS}	V _{GS} =0V, I _D = 250μA	650	-	-	V
Drain-Source Leakage Current		I _{DSS}	V _{DS} =650V, V _{GS} =0V	-	-	1	μA
Gate-Source Leakage Current	Forward	I _{GSS}	V _{GS} =30V, V _{DS} =0V	-	-	100	nA
	Reverse		V _{GS} =-30V, V _{DS} =0V	-	-	-100	nA
On characteristics							
Gate Threshold Voltage		V _{GS(TH)}	V _{DS} =V _{GS} , I _D =250μA	2.0	-	4.0	V
Static Drain-Source On-State Resistance		R _{DS(ON)}	V _{GS} =10V, I _D =10A	-	0.4	0.45	Ω
Dynamic characteristics							
Input Capacitance		C _{ISS}	V _{GS} =0V, V _{DS} =25V, f=1.0MHz	-	2512	-	pF
Output Capacitance		C _{OSS}		-	231	-	pF
Reverse Transfer Capacitance		C _{RSS}		-	14	-	pF
Switching characteristics							
Total Gate Charge (Note 1)		Q _G	V _{DS} =100V, V _{GS} =10V, I _D =20A I _G =1mA (Note 1, 2)	-	54	-	nC
Gate-source Charge		Q _{GS}		-	10	-	nC
Gate-Drain Charge		Q _{GD}		-	13	-	nC
Turn-on Delay Time (Note 1)		t _{D(ON)}	V _{DS} =100V, V _{GS} =10V, I _D =20A, R _G =25Ω (Note 1, 2)	-	28	-	ns
Rise Time		t _R		-	35	-	ns
Turn-off Delay Time		t _{D(OFF)}		-	140	-	ns
Fall-Time		t _F		-	76	-	ns
Source-drain diode ratings and characteristics							
Maximum Body-Diode Continuous Current		I _S		-	-	20	A
Maximum Body-Diode Pulsed Current		I _{SM}		-	-	40	A
Drain-Source Diode Forward Voltage (Note 1)		V _{SD}	V _{GS} =0V, I _S =20A	-	-	1.4	V
Reverse Recovery Time (Note 1)		t _{rr}	V _{GS} =0V, I _S =20A,	-	506	-	ns
Reverse Recovery Charge		Q _{rr}	dI _F /dt=100A/μs (Note1)	-	9	-	μC

Notes: 1. Pulse Test : Pulse width ≤ 300μs, Duty cycle ≤ 2%.

2. Essentially independent of operating temperature.

■ TEST CIRCUITS AND WAVEFORMS

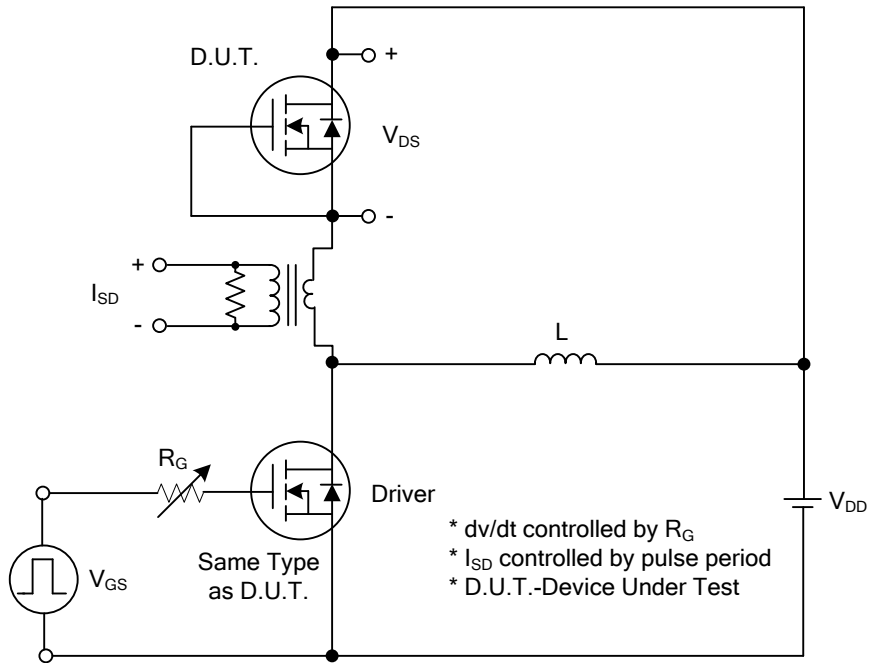

Peak Diode Recovery dv/dt Test Circuit

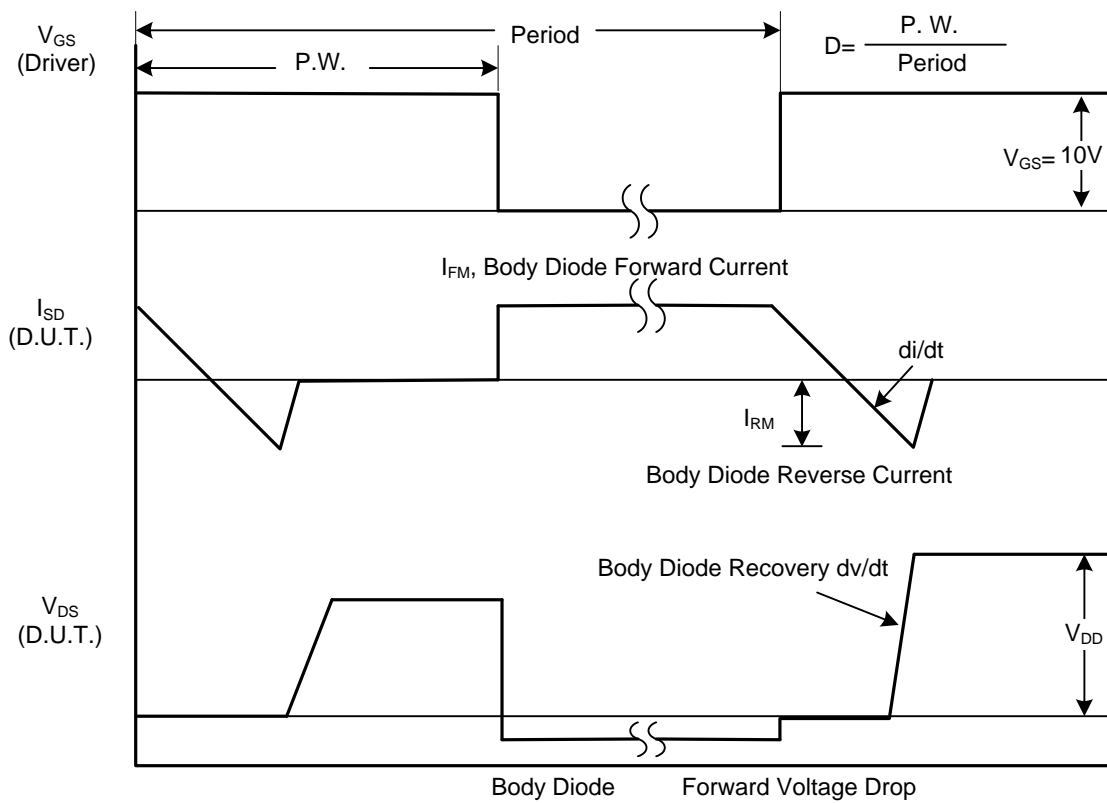

Peak Diode Recovery dv/dt Waveforms

■ TEST CIRCUITS AND WAVEFORMS(Cont.)

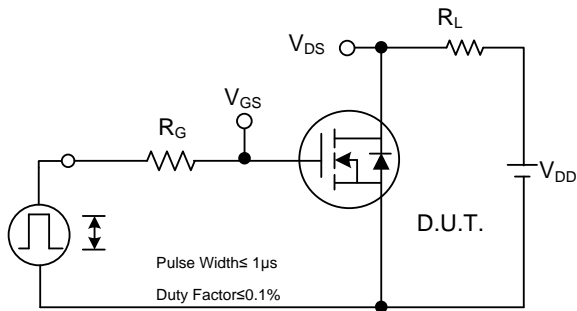

Switching Test Circuit

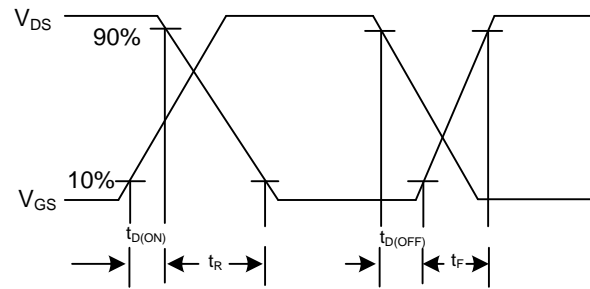

Switching Waveforms

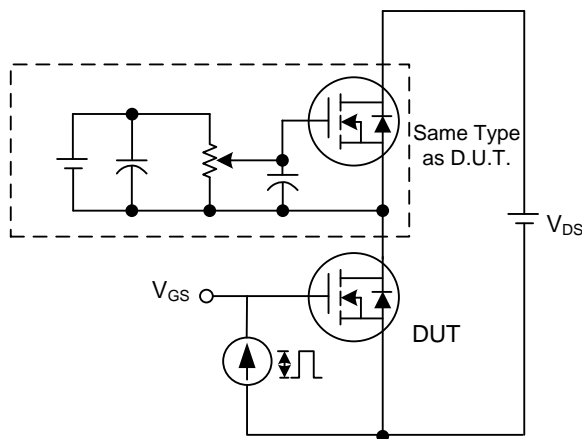

Gate Charge Test Circuit

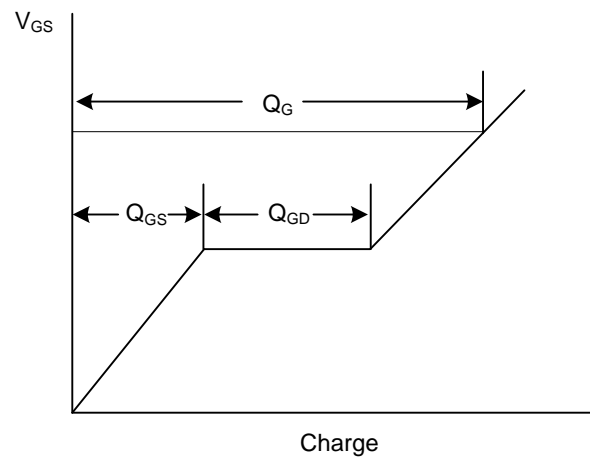

Gate Charge Waveform

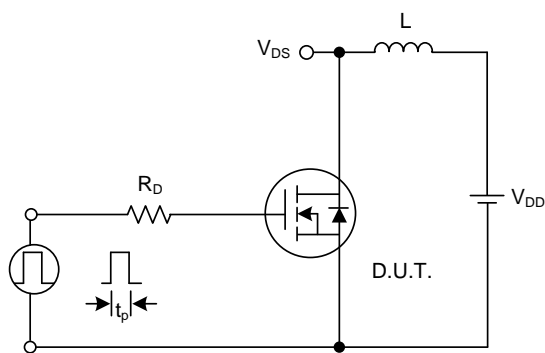

Unclamped Inductive Switching Test Circuit

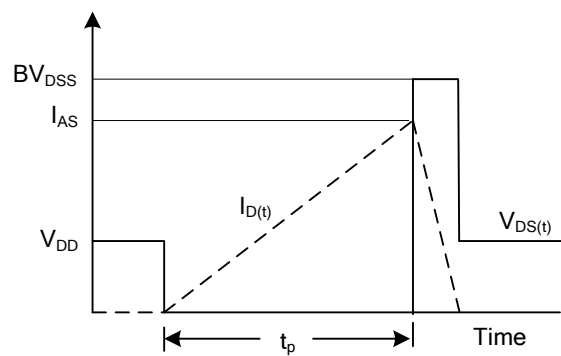

Unclamped Inductive Switching Waveforms

■ TYPICAL CHARACTERISTICS

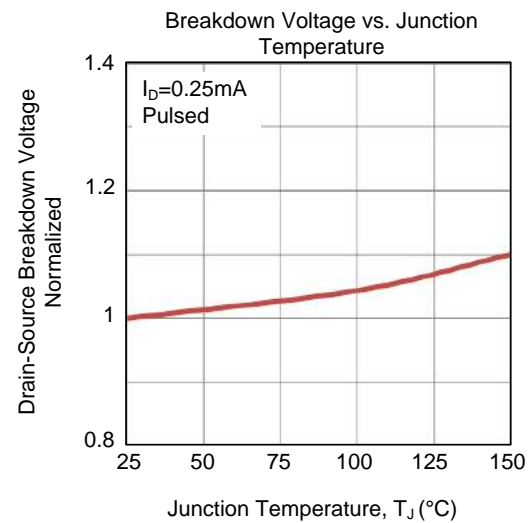
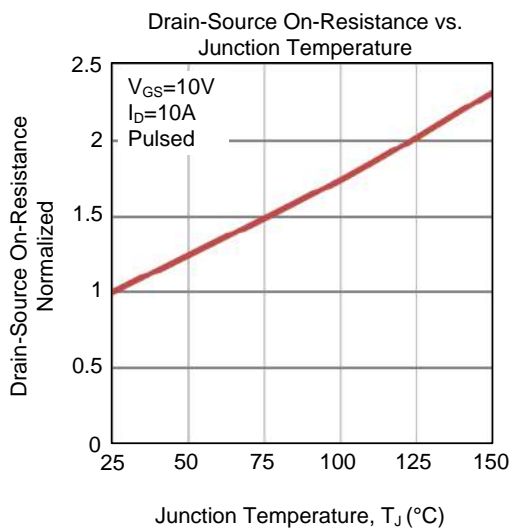
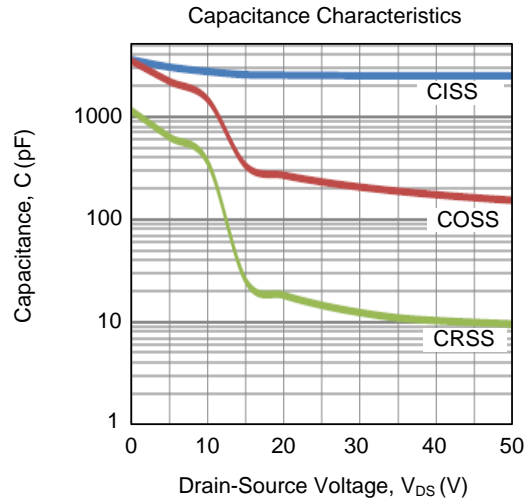
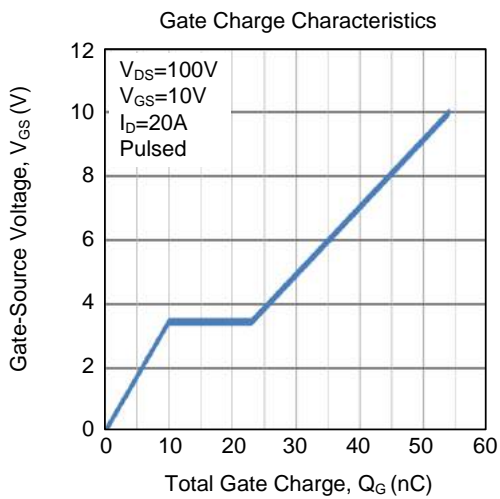
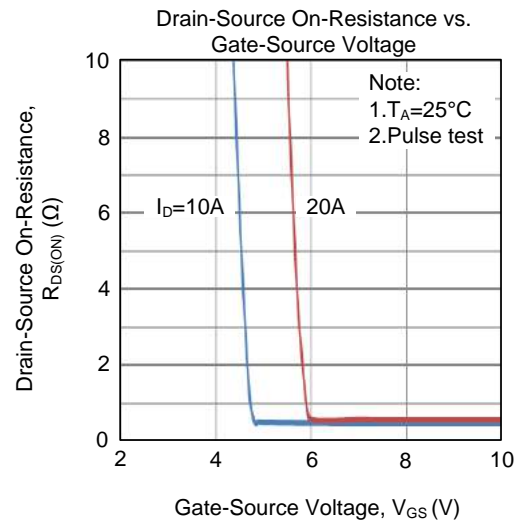
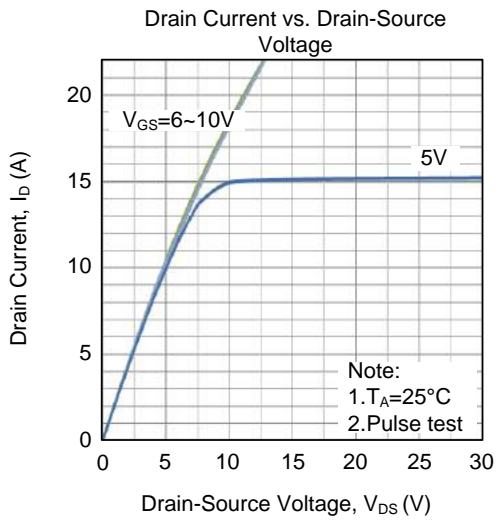

■ TYPICAL CHARACTERISTICS(Cont.)

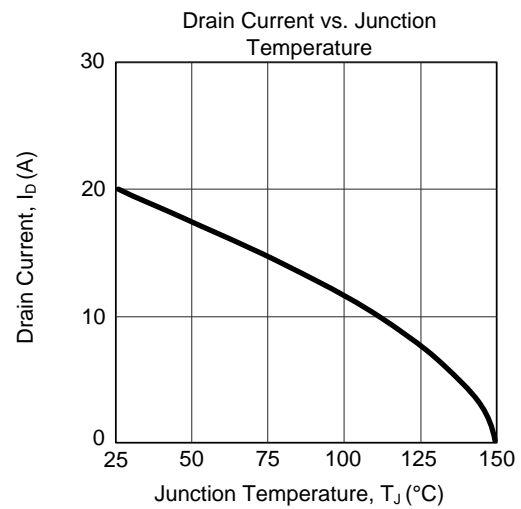
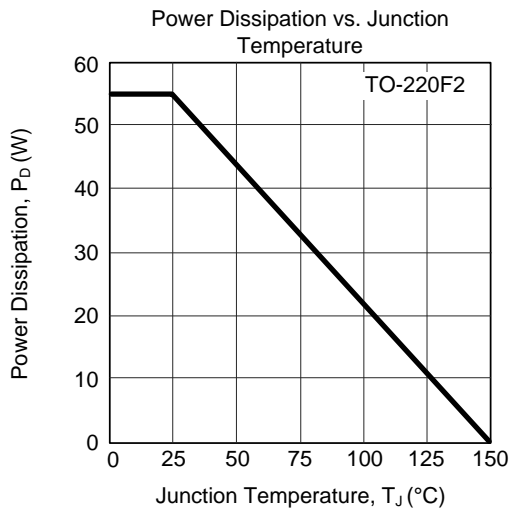
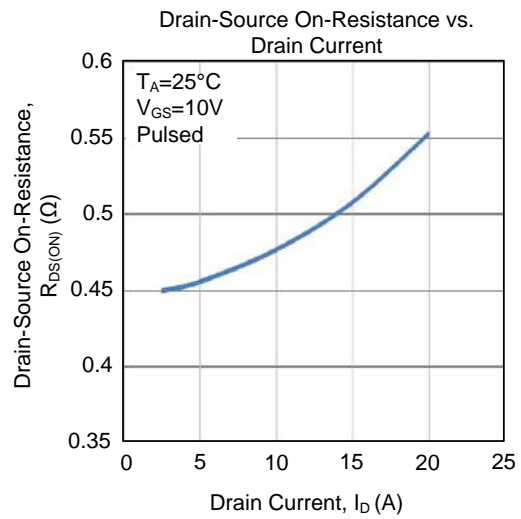
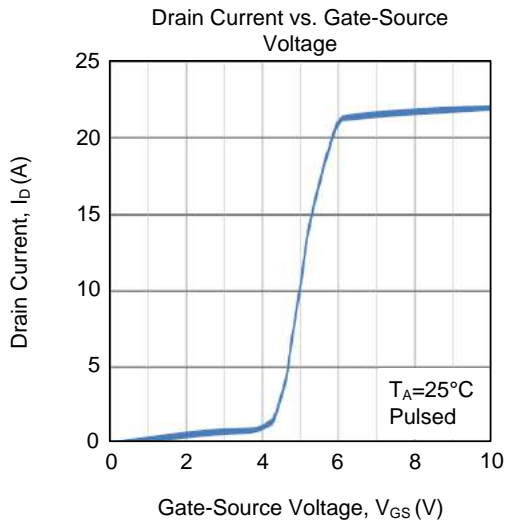
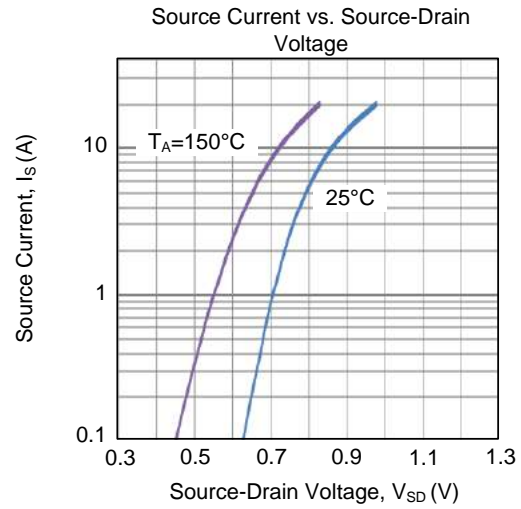
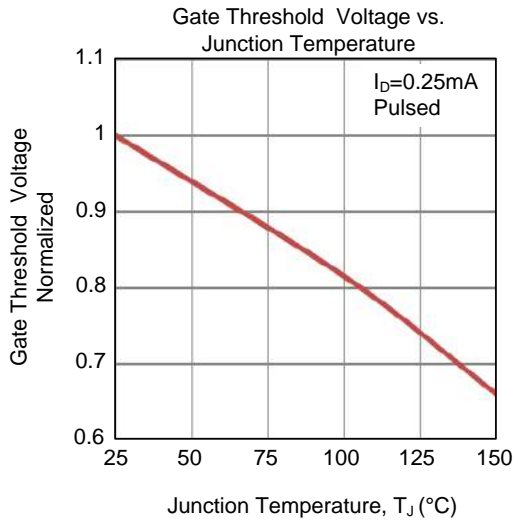

■ TO-220F-3L PACKAGE OUTLINE DIMENSIONS

