

■ PRODUCT CHARACTERISTICS

V _{DSS}	20V
R _{DS(ON)Typ} (@V _{GS} =2.5V)	4mΩ
R _{DS(ON)Typ} (@V _{GS} =4.5V)	2.8mΩ
I _D	100A

■ APPLICATIONS

Power management in telecom., industrial automation, CE
Current switching in DC/DC-AC/DC sub-systems
Motor driving in power tool
E-vehicle, robotics

■ FEATURES

- *Low gate charge
- *UIS tested, 100% Rg tested
- *Pb-free lead plating
- *Halogen-free and RoHS-compliant

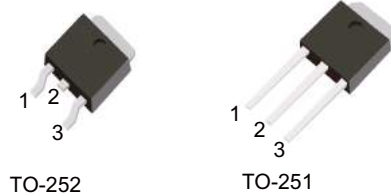
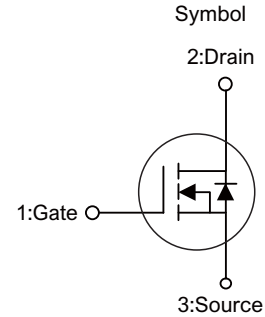

■ ORDER INFORMATION

Order codes		Package	Packing
Halogen-Free	Halogen		
N/A	MOT100N02D	TO-252	2500 pieces/Reel
N/A	MOT100N02C	TO-251	70 pieces/Tube

■ ABSOLUTE MAXIMUM RATINGS (T_C = 25°C, unless otherwise specified)

Parameter	Symbol	Ratings	Unit	
Drain-to-source voltage	V _{DSS}	20	V	
Gate-to-source voltage	V _{GSS}	±12	V	
Continuous drain	T _C =25°C	I _D	100	A
	T _C =100°C	I _D	70	A
Pulsed drain current	I _{DM}	360	A	
Avalanche energy	E _{AS}	118	mJ	
Power dissipation	P _D	88	W	
Junction & storage temperature range	T _J , T _{STG}	~55 to +150	°C	

■ THERMAL PERFORMANCE

Parameter	Symbol	Ratings	Unit
Thermal resistance, Junction-to-case	R _{θJC}	1.8	°C/W

■ ELECTRICAL CHARACTERISTICS($T_C = 25^\circ\text{C}$, unless otherwise specified)

Parameter	Symbol	Conditions	Min	Typ	Max	Unit
STATIC PARAMETERS						
Drain-source breakdown voltage	$V_{(BR)DSS}$	$V_{GS}=0V, I_D=250\mu A$	20	-	-	V
Zero gate voltage drain current	I_{DSS}	$V_{DS}=20V, V_{GS}=0V$ $T_J=55^\circ\text{C}$	-	-	1	μA
			-	-	5	μA
Gate-body leakage current	I_{GSS}	$V_{GS}=\pm 12V, V_{DS}=0V$	-	-	± 100	nA
Gate threshold voltage	$V_{GS(th)}$	$V_{DS}=V_{GS}, I_D=250\mu A$	0.5	-	1.1	V
Static drain-source on-resistance	$V_{GS(th)}$	$V_{GS}=4.5V, I_D=30A$	-	2.8	4.0	m Ω
		$V_{GS}=2.5V, I_D=20A$	-	4.0	6.0	m Ω
Forward transconductance	g_{FS}	$V_{DS}=5V, I_D=5A$	-	-	50	S
Diode forward voltage	V_{SD}	$I_S=1A, V_{GS}=0V$	-	0.75	1	V
Diode continuous current	I_S	$T_C=25^\circ\text{C}$	-	-	100	A
DYNAMIC PARAMETERS						
Input capacitance	C_{ISS}	$V_{GS}=0V, V_{DS}=10V, f=1\text{MHz}$	-	3200	-	pF
Output capacitance	C_{OSS}		-	460	-	pF
Reverse transfer capacitance	C_{rSS}		-	445	-	pF
Gate resistance	R_g	$V_{GS}=0V, V_{DS}=0V, f=1\text{MHz}$	-	1.4	-	Ω
SWITCHING PARAMETERS						
Total charge	Q_g	$V_{GS}=4.5V$ $V_{DS}=10V, I_D=30A$	-	48	-	nC
Gate source charge	Q_{gs}		-	3.6	-	nC
Gate drain charge	Q_{gd}		-	19	-	nC
Turn-on delay time	$t_{D(on)}$	$V_{GS}=4.5V, V_{DD}=10V$ $I_D=30A, R_{GEN}=1.8\Omega$	-	9.7	-	nS
Turn-on rise time	t_r		-	37	-	nS
Turn-off delay time	$t_{D(off)}$		-	63	-	nS
Turn-off fall time	t_f		-	52	-	nS
Body-diode reverse recovery time	t_{rr}	$I_F=30A, dI_F/dt=100A/\mu s$	-	23	-	nS
Body-diode reverse recovery charge	Q_{rr}	$I_F=30A, dI_F/dt=100A/\mu s$	-	10	-	nC

■ TYPICAL CHARACTERISTICS

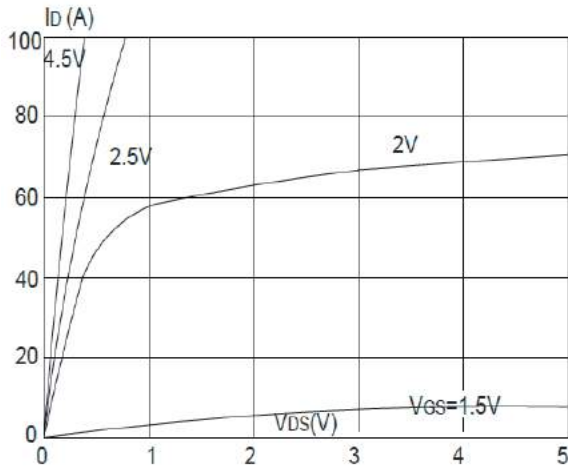

Figure 1: Output Characteristics

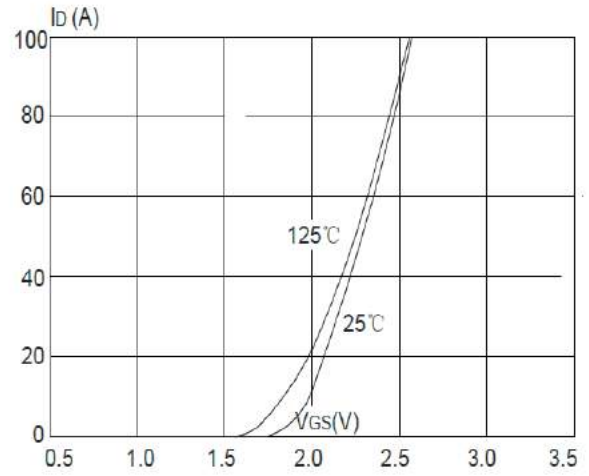

Figure 2: Typical Transfer Characteristics

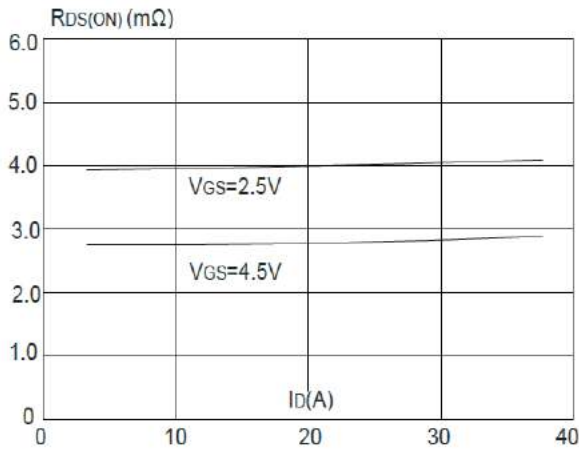

Figure 3: On-resistance vs. Drain Current

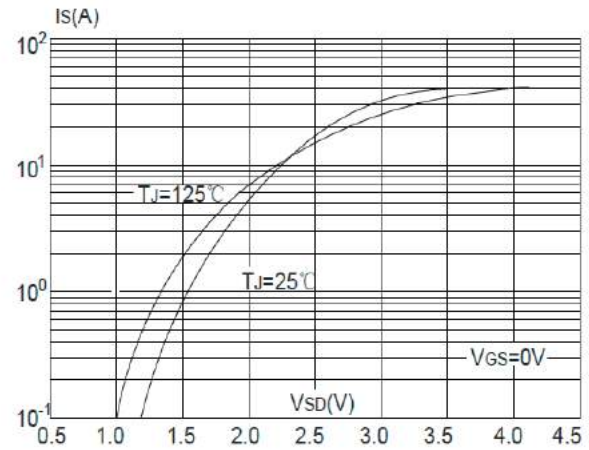

Figure 4: Body Diode Characteristics

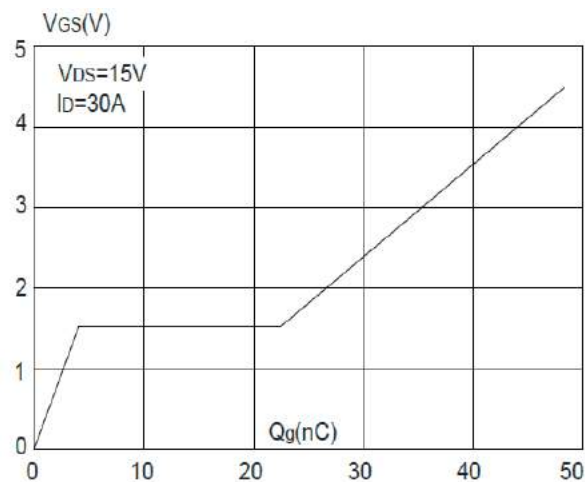

Figure 5: Gate Charge Characteristics

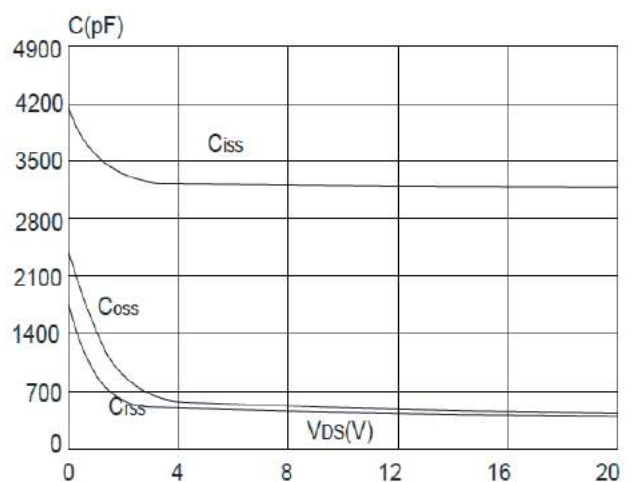

Figure 6: Capacitance Characteristics

■ TYPICAL CHARACTERISTICS(Cont.)

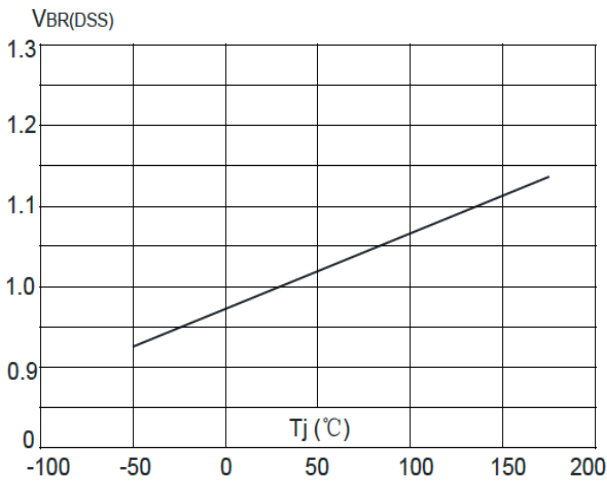

Figure 7: Normalized Breakdown Voltage vs. Junction Temperature

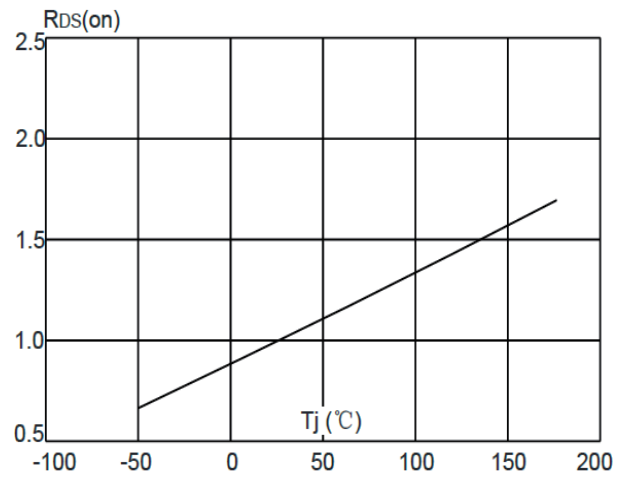

Figure 8: Normalized on Resistance vs. Junction Temperature

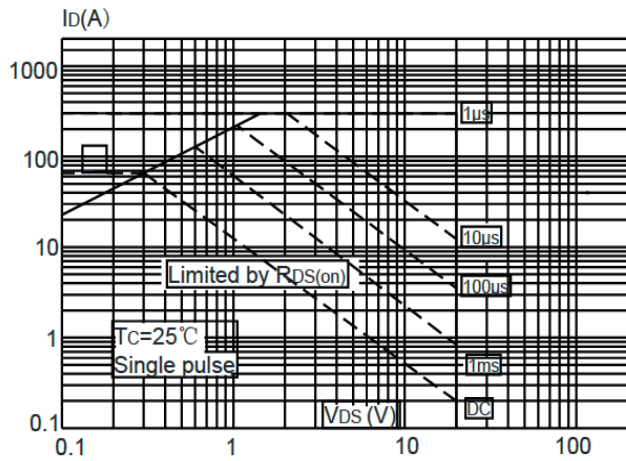

Figure 9: Maximum safe operating area

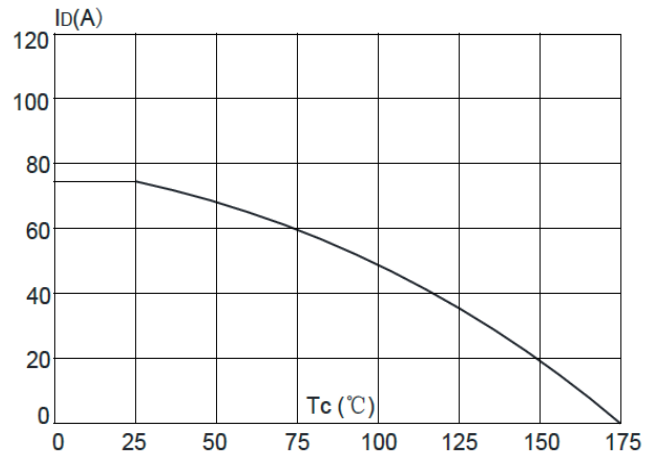

Figure 10: Maximum drain current vs. case Temperature

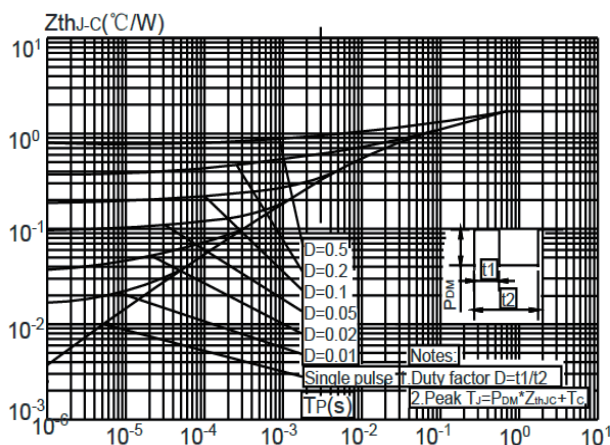
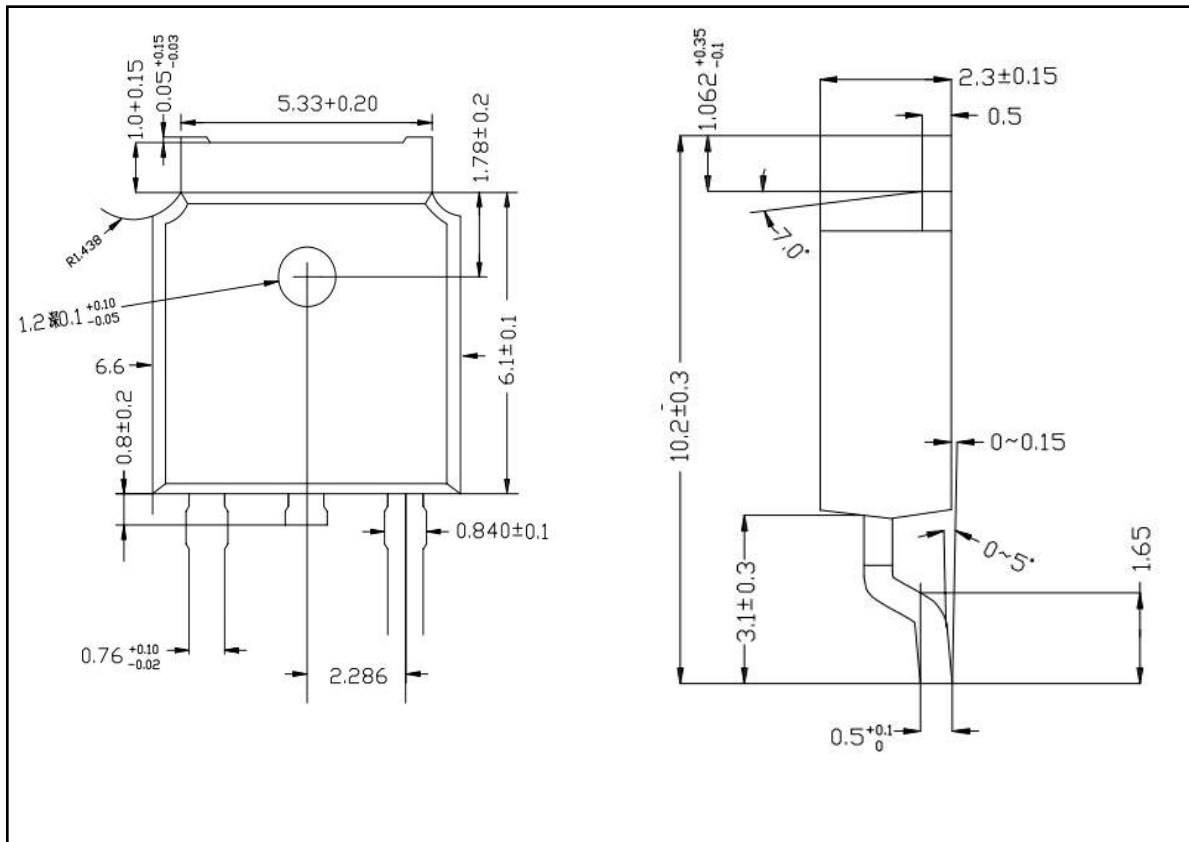

Figure 11: Maximum Effective Transient Thermal Impedance, Junction-to-Casense curve

■ TO-252 PACKAGE OUTLINE DIMENSIONS



■ TO-251 PACKAGE OUTLINE DIMENSIONS

