



MBRF4045CT

Dual High Voltage Schottky Rectifier

● Features:

- Common Cathode Structure
- Low Power Loss and High Efficiency
- Low Forward Voltage Drop
- High Surge Capability

● Application:

- High Frequency Switch
- Free Wheeling, and Polarity Protection Applications

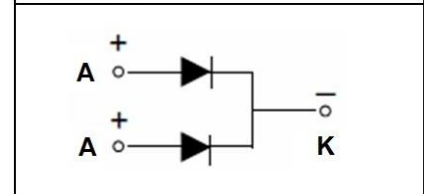
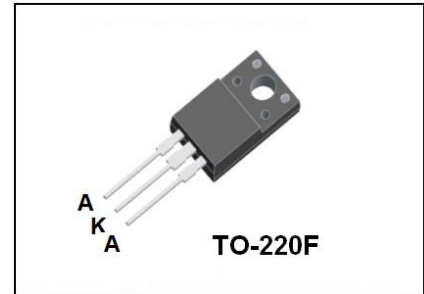

Absolute Maximum Ratings (T_c=25°C unless otherwise noted)

Symbol	Parameter	Value	Unit
V _{RRM}	Maximum Repetitive Reverse Voltage	45	V
V _R	Maximum DC Reverse Voltage	45	V
I _{F(AV)}	Average Rectified Forward Current, T _c =120°C	20(Per Leg) 40(Per Device)	A
I _{FSM}	Peak Forward Surge Current, 8.3ms Half Sine wave	250	A
T _j	Operating Junction Temperature	150	°C
T _{stg}	Storage Temperature Range	-55 to +150	°C

Thermal Characteristics (T_c=25°C unless otherwise noted)

Symbol	Parameter	Max	Unit
R _{θJC}	Thermal Resistance, Junction to Case Per Leg	3.0	°C / W

Electrical Characteristics (T_c=25°C unless otherwise noted)

Symbol	Parameter	Test Conditions	Min	Max	Unit
V _{RRM}	Maximum Repetitive Reverse Voltage	I _R =250μA	45		V
I _R	Reverse Current	V _R =45V T _c =25°C V _R =45V T _c =125°C		0.3 60	mA
V _F	Forward Voltage	I _F =20A T _c =25°C I _F =20A T _c =125°C I _F =40A T _c =25°C I _F =40A T _c =125°C		0.81 0.76 0.91 0.86	V

V_F Typical Values: 0.71V@ I_F=20A, T_c=25°C

Typical Performance Characteristics

Figure 1. Forward Current Characteristics

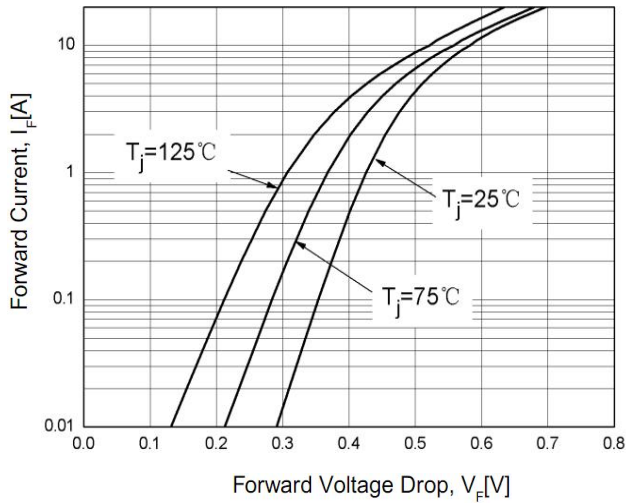

Figure 2. Reverse Leakage Current

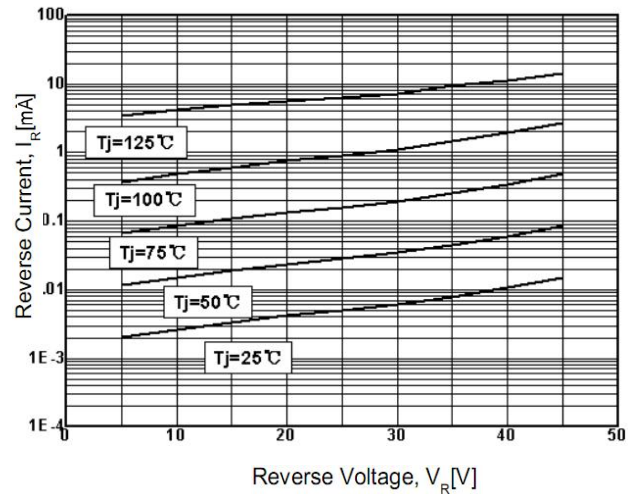

Figure 3. Junction Capacitance

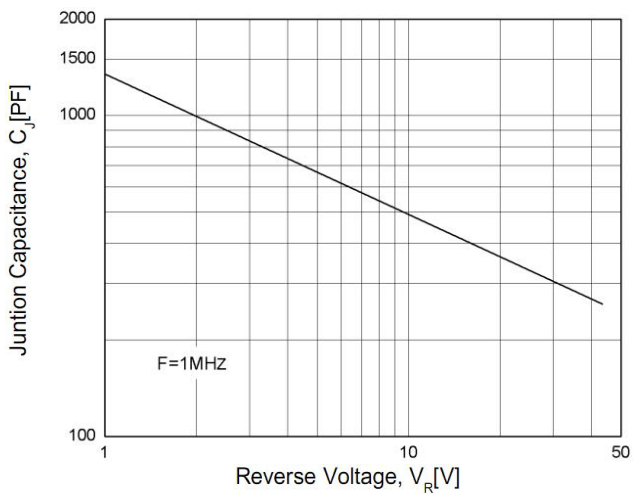
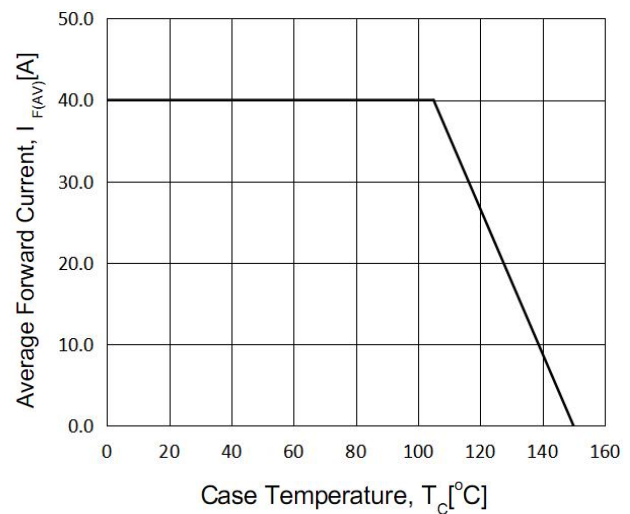

Figure 4. Power Derating



TO-220F Package Dimensions

UNIT: mm

SYMBOL	min	nom	max	SYMBOL	min	nom	max
A	9.80		10.60	D		2.54	
A1		7.00		D1	1.15		1.47
A2	2.90		3.40	D2	0.60		0.90
A3	9.10		9.90	D3	0.20		0.50
B1	15.40		16.40	E	2.24		2.84
B2	4.35		4.95	E1		0.70	
B3	6.00		7.40	E2		1.0 × 45°	
C	3.00		3.70	E3	0.35		0.65
C1	15.00		17.00	E4	2.30		3.30
C2	8.80		10.80	α (度)		30°	
C3	2.60		3.60				

