

MESSRS.

SPECIFICATION FOR APPROVAL**承 认 书**

Product	ELECTRET CONDENSER MICROPHONE
Part No.	HMB-O40J40-CWH4(RoHS)
Customer Part No.	
Customer Approval	

Approved By	Checked By	Made By
王台平 DEC-03-2014	曹丽萍 DEC-03-2014	LILY DEC-03-2014

常州华龙电子有限公司**DRAGONSTATE ELECTRONIC CORPORATION**

中国江苏省常州市新区电子园新四路 36 号

Tel: +86-519-85110078. 86-519-85106698, Fax: +86-519-85101081**EDITION:1.2**

1. 变更记录 (History change record)

Change Items	Date	Note	Drawn by	Checked by
	2014-03-13	First Issue	Lily	王台平 2014-03-13
曲线修改	2014-12-03	版本 2.0 版	Lily	王台平 2014-12-03

2. 储藏与判断条件 (Storage And Judgement Conditions)

	Temperature Range(°C)	Rel. Humidity(%)	Static Pressure(kPa)
Judgement	19~21	60~70	86~106
Storage	-25~70		
Operating	-25~70		

3. 规格 (Specifications)

Test conditions($V_S=2.0V$ $R_L=2.2k\Omega$ $Temp=20\pm 2^\circ C$ $R.H=60\pm 5\%$)

Item	Symbol	Test Conditions	Min	Standard	Max	Unit
灵敏度 Sensitivity	S	$f=1kHz, Pin=1Pa$	-43	-40	-37	dB ($0dB=1V/Pa$)
阻抗 Impedance	Z	$f=1kHz, Pin=1Pa$			2.2	$k\Omega$
指向性 Directivity	Omni-directional					
消耗电流 Current Consumption	I				500	μA
工作电压 Operation Voltage Range	U		1.0	2.0	10	V
信噪比 S/N Ratio	S/N(A)	$f=1kHz, Pin=1Pa$ A Curve	58			dB
降压特性 Decreasing Voltage Characteristic	ΔS	$f=1kHz, Pin=1Pa$ $V_S=2.0-1.5V$			-3	dB
最大输入声压级 Max.Input Sound Level	MISPL	$f=1kHz$ Distortion<1%			110	dB

4. 测试电路 (Standard Test Circuit)

$V_S=2.0V$ $R_L=2.2k\Omega$ $Te=20^\circ C$ $R.H.=60\%$

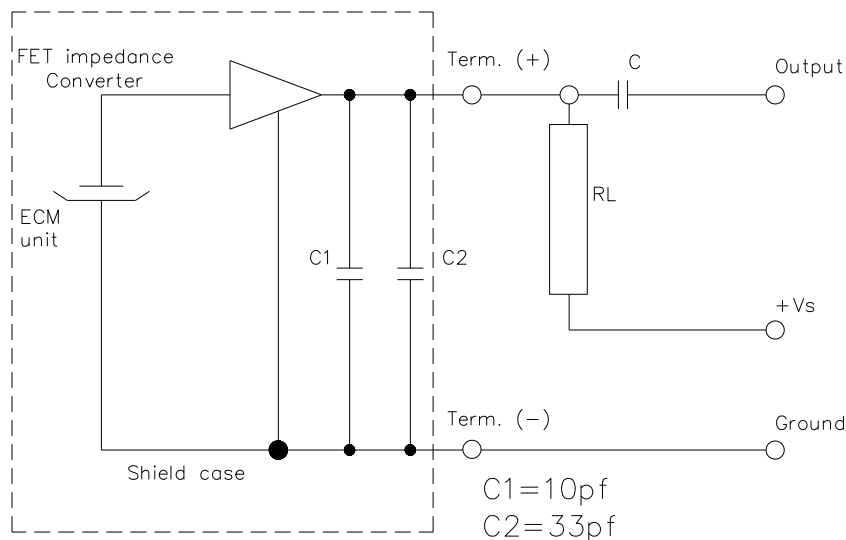

5. 测试装备图 (Standard Test Fixture)

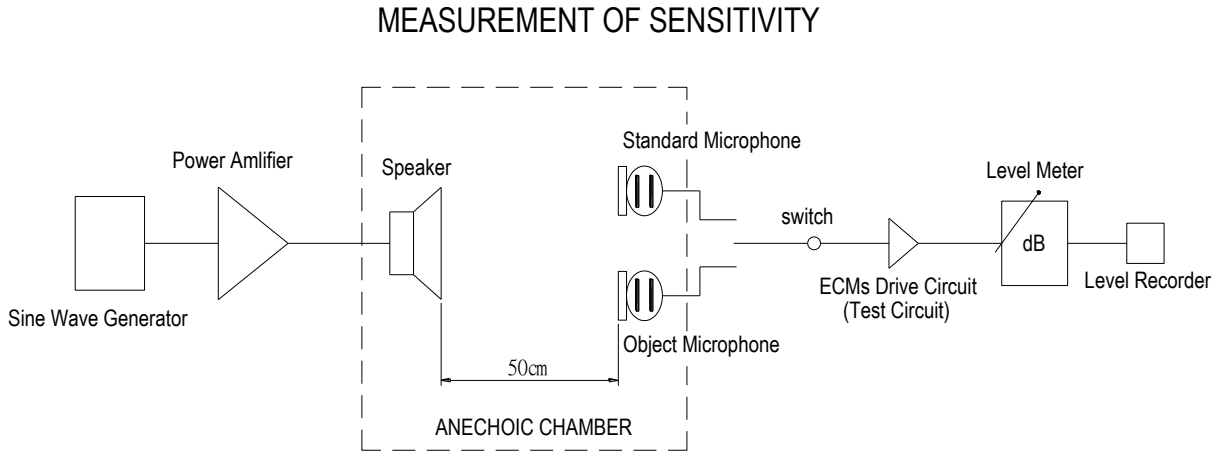

6 频响曲线 (Frequency Response Curve)

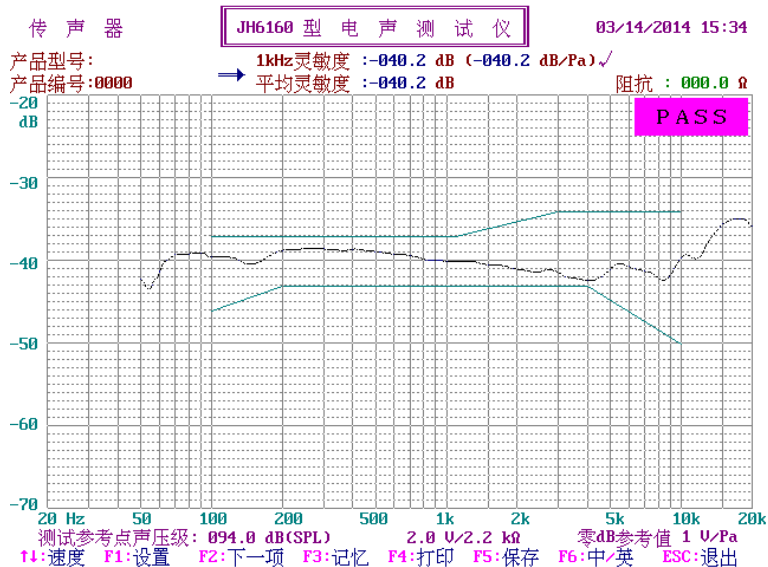
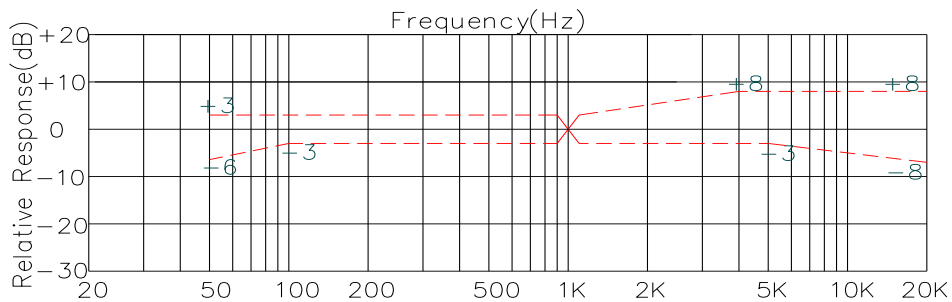

7,外观图 (Appearance Drawing)

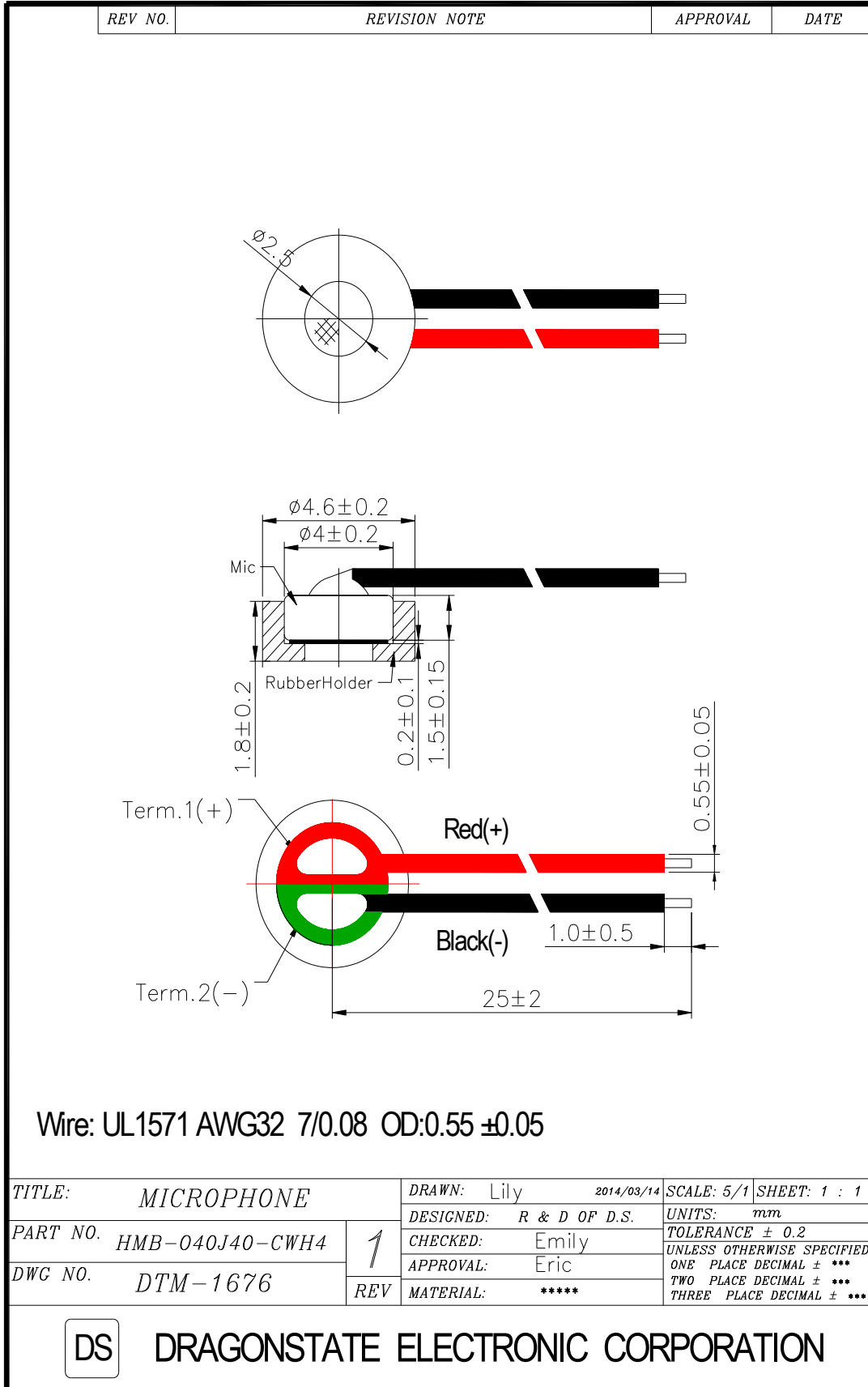

8. 材料及结构清单 (List and Structure of Materials)

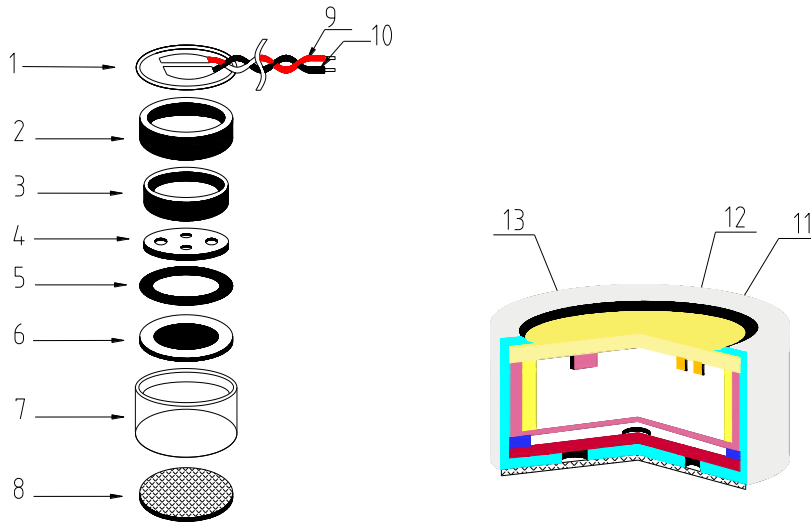

No. 序号	Part name 部件名称	Material Type 材料型号	Qty 数量	Origin 产地	Manufacture 协力厂商	Remarks 备注
1	PCB	Epoxy FR-4	1	Hongkong	Jiantao	
2	Cavity	POM	1	Japan	Suzhou	
3	Copper ring	Brass AT65	1	China	Suzhou	
4	Back plate	ALSET FC-CNZ	1	Korea	3A	
5	Cushion plate	Mylar	1	China	Hebei	
6	Diaphragm	PPS	1	Japan	Dongli	
7	Case	Magal	1	China	Shanghai	
8	Cloth	non-woven fabrics	1	Japan	Sanjing	
9	Lead wire	UL1571 AWG 32	1	China	Shanghai	Red+
10	Lead wire	UL1571 AWG 32	1	China	Shanghai	Black-
11	Capacitor	10pF 0402	1	Japan	Murata	
12	Capacitor	33pF 0402	1	Japan	Murata	
13	FET	TF252THC	1	Japan	Sanyo	

9.可靠性试验 (Reliability Test)

在下列试验完成后,在温度为 20°C,相对湿度为 65%的条件下恢复 3 小时后进行测试,灵敏度与初始灵敏度相差在±3dB 以内.

(All tests should be done after 3 hours of conditioning at 20°C, R.H65%, while the sensitivity is to be within ±3dB,from the initial sensitivity after the following experiments.)

9.1 高温试验 (HIGH TEMPERATURE TEST)

温度(High temperature): +70°C

放置时间(Duration): 200hours

9.2 低温试验 (LOW TEMPERATURE TEST)

温度(Low temperature): -25°C

放置时间(Duration): 240 hours

9.3 温度循环试验(如图 1) (TEMPERATURE CYCLE TEST)(See in Fig.1)

低温(Low temperature): -25°C

高温(High temperature): +70°C

转化时间(Changeover time): 10min

放置时间(Duration): 30min

次数(Cycle): 5

9.4 湿度 (STATICAL HUMIDITY TEST)

温度(Temperature): +60°C

相对湿度(Relative humidity): 90 ~ 95%

放置时间(Duration): 200 hours

9.5 振动试验 (VIBRATION TEST)

振幅(Amplitude): 1.52mm

持续时间(Duration): 1 分钟/面(minutes/plane)

频度范围(Freq.range): 10 ~ 55Hz

试验时间(Total time): 2 小时(hour)

9.6 跌落试验 (DROP TEST)

不带包装的跌落到 20mm 厚的地板上(Drop a unit unpacked onto a board of 20mm thick)

高度(Height): 1 m

次数(Cycle): 6 (1 each plane)

9.7 静电测试 (ESD TEST)

在两次无杂质的静电释放暴露中放电.(接触:±8Kv,空气:±15 Kv)麦克风在 10 次暴露后无干扰

The microphone under test must be discharged between each ESD exposure without ground.

(contact:±8 kV, air:±15 kV)There is no interference in operation after 10 times exposure.

10. 焊接要求 (Regarding the Soldering operation)

每个驻极体电容传声器在其麦克风上都有一个 FET,这种 FET 在过热和电流撞击时易损坏，所以对于焊接应遵

循以下操作：

- 要求使用 25W-35W 烙铁，并保持 $350\pm 10^{\circ}\text{C}$ 的温度范围。
- 在每一个端的焊接应在 2 秒内完成，以防过热。
- 禁止单体麦克风焊接。(否则会影响驻极体电容传声器的灵敏度)
- 最理想的散热装置按以下设计。

Every ECM contains a FET with microphone body.

This FET easy to damageable from excessive heat and electrical shock. Proper attention for the soldering work is required same as followings.

- Recommend to use 25W-35W ceramic soldering iron and apply $350\pm 10^{\circ}\text{C}$ temperature range
- Soldering should be accomplished within 2 seconds at each terminal so as not to be overheated.
- Do not make a cavity at the surface of lead lump on the PCB. wiring board.

(Opened cavity will influence to the sensitivity of ECM)

- Optimal design for heat sink pad is same as below.

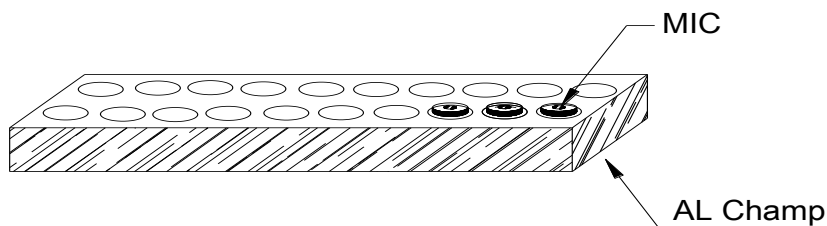

11. 包装规格 (Packing Specifications)

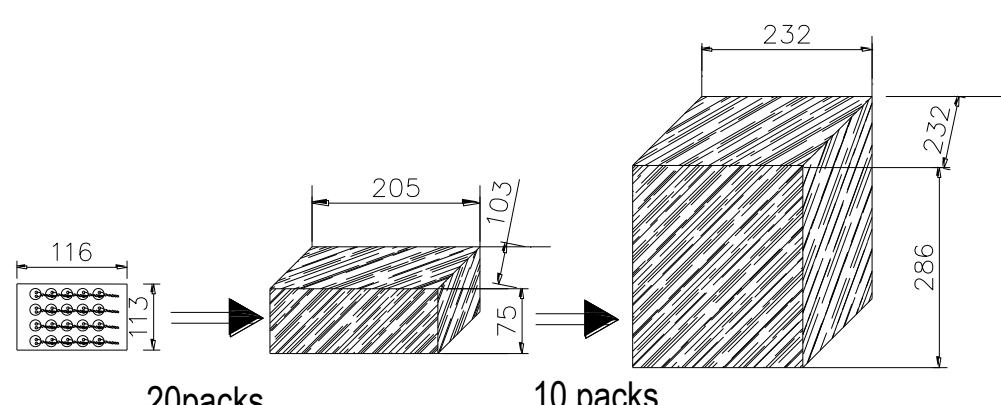
REV NO.	REVISION NOTE	APPROVAL	DATE
			
100pcs per plastic bag	1000pcs per plastic box	10000pcs per out bag	
N/W:15g G/W:20g	N/W:300g G/W:450g	N/W:3.0KG G/W:5.5KG	
MODEL:	MODEL:	MODEL:	
QTY:100PCS	QTY:1000PCS	QTY:10000PCS	
LOT NO:	LOT NO:	LOT NO:	
TITLE: packing		DRAWN: <i>Lily</i> 2013/01/16	SCALE: 5/1 SHEET: 1 : 1
PART NO.		DESIGNED: R & D OF D.S.	UNITS: mm
DWG NO.		CHECKED: <i>Emily</i>	TOLERANCE ± 0.2
		APPROVAL: <i>Eric</i>	UNLESS OTHERWISE SPECIFIED: ONE PLACE DECIMAL ± *** TWO PLACE DECIMAL ± *** THREE PLACE DECIMAL ± ***
REV 1		MATERIAL: *****	
DS DRAGONSTATE ELECTRONIC CORPORATION			