



江苏宇飞特电子科技有限公司

承 认 书

SPECIFICATION FOR APPROVAL

客户名称:

CUSTOMER _____

产品名称:

PART NAME _____ 片式PTC热敏电阻 _____ 产品

规格:

PART NUMBER _____ **YFT0603/0805** _____

日期:

DATE _____ **2020/8/10** _____

供应商确认签章栏

品质部	工程部	批准

客户确认签章栏

品质部	工程部	批准

江苏宇飞特电子科技有限公司

地址: 南京市江宁区滨江开发区宝象路5号

TEL: 025-52799992/18951979776

FAX: 025-52799992

<http://www.yftdz.cn>

E-MAIL: yftr001@163.com

1 外形尺寸 Shape and Dimensions

- 尺寸: 见图 1 和表 1
- PCB 焊盘: 见图 2 和表 1
- Dimensions: See Fig.1 and Table 1.
- Recommended PCB pattern for reflow soldering: See Fig.2 and Table 1



图 1 Fig.1



图 2 Fig.2

表 1 (Table 1)

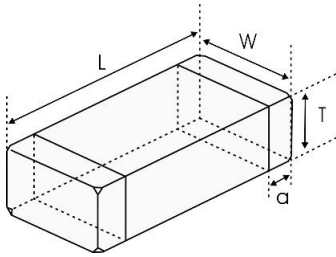
单位 unit: inch[mm]

类别 Type	L	W	T	a	A	B	C
0603 [1608]	0.063±0.006 [1.6±0.15]	0.031±0.006 [0.8±0.15]	0.031±0.006 [0.8±0.15]	0.012±0.008 [0.3±0.2]	[0.6-0.8]	[0.6-0.7]	[0.6-0.8]
0805 [2012]	0.079±0.008 [2.0±0.2]	0.049±0.008 [1.25±0.2]	0.033±0.008 [0.85±0.2]	0.020±0.012 [0.5±0.3]	[1.0-1.1]	[0.6-0.7]	[1.0-1.2]

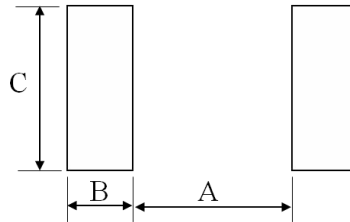
2 产品标识 (料号) Product Identification(Part Number)

YFT 0603 R 471 Q 130
① ② ③ ④ ⑤ ⑥

① 类别 Type	
YFT	片式PTC 热敏电阻器品牌 Chip PTC Thermistor Brand

③分隔符 Delimiter	
	R

⑥居里温度点 Cuic point temperature	
120	120°C
110	110°C
100	100°C
090	90°C
080	80°C
070	70°C
060	60°C
050	50°C

④25°C的零功率电阻 Nominal Zero-Power Resistance	
471	470Ω

② 外形尺寸(mm) External Dimensions (L×W×T)	
0603	1.60×0.8 0×0.8 0
0805	2.00×1.25×0.85

⑤电阻值特定允许公差 Resistance special tolerance	
代号 Code	检测温度允许偏差 Sensing temp. tolerance
Q	±5°C
R	±3°C

3 电气特性 Electrical Characteristics

1) YFTS0603 (1608) 系列 YFTS0603 (1608) Series

型号 Part No	居里温度 Curie temperature (°C)	传感温度 Sensing temperature (4.7kΩ) (°C)	传感温度 Sensing temperature (47kΩ) (°C)	允许电压 Allowable voltage (V)	电阻值 Resistance (25°C) (Ω)	工作温度范围 Range of working temperature (°C)
YFT0603R471Q12 0	120	135±5°C	150±7°C	32	470±50%	-20~160
YFT0603R471Q11 0	110	125±5°C	140±7°C	32	470±50%	-20~150
YFT0603R471Q10 0	100	115±5°C	130±7°C	32	470±50%	-20~140
YFT0603R471Q09 0	90	105±5°C	120±7°C	32	470±50%	-20~130
YFT0603R471Q08 0	80	95±5°C	110±7°C	32	470±50%	-20~120
YFT0603R471Q07 0	70	85±5°C	100±7°C	32	470±50%	-20~110
YFT0603R471Q06 0	60	75±5°C	90±7°C	32	470±50%	-20~100
YFT0603R471Q05 0	50	65±5°C	80±7°C	32	470±50%	-20~90

2) YFTS0805 (2012) 系列 YFTS0805 (2012) Series

型号 Part No	居里温度 Curie temperature (°C)	传感温度 Sensing temperature (4.7kΩ) (°C)	允许电压 Allowable voltage (V)	电阻值 Resistance (25°C) (Ω)	工作温度范围 Range of working temperature (°C)
YFT0805R471Q120	120	135±5°C	32	470±50%	-20~150
YFT0805R471Q110	110	125±5°C	32	470±50%	-20~140
YFT0805R471Q100	100	115±5°C	32	470±50%	-20~130
YFT0805R471Q090	90	105±5°C	32	470±50%	-20~120
YFT0805R471Q080	80	95±5°C	32	470±50%	-20~110
YFT0805R471Q070	70	85±5°C	32	470±50%	-20~100

4 检验和测试程序

■ 测试条件

如无特别规定，检验和测试的标准大气环境条件如下：

- 环境温度：20±15℃；
- 相对湿度：65±20%；
- 气压：86 kPa~106 kPa

如果对测试结果有异议，则在下述条件下测试：

- 环境温度：25±2℃；
- 相对湿度：65±5%
- 气压：86kPa ~ 106kPa

■ 检查设备

外观检查：20 倍放大镜；

阻值检查：热敏电阻测试仪

4 and Measurement Procedures

Test Conditions

Unless otherwise specified, the standard atmospheric conditions for measurement/test as:

- Ambient Temperature: 20±15℃
- Relative Humidity: 65±20%
- Air Pressure: 86kPa to 106kPa

If any doubt on the results, measurements/tests should be made within the following limits:

- Ambient Temperature: 25±2℃
- Relative Humidity: 65±5%
- Air Pressure: 86kPa to 106kPa

Inspection Equipment

Visual Examination: 20× magnifier

Resistance value test: Thermistor resistance tester

5 电性测试 Electrical Test

序号 No.	项目 Items	测试方法及备注 Test Methods and Remarks
1	25℃零功率电阻值 Nominal Zero-Power Resistance at 25℃(R25)	在施加最大工作电压3分钟并在 25° C 温度下搁置2小时后，施加小于DC1.5V 的电压（小于 10mA 的直流电流）来进行测量。 After applying maximum operating voltage for 3min. and leaving for 2hrs. in 25°C, measured by applying voltage less than DC1.5V. (by a direct current less than 10mA)
2	居里温度 Curie temperature (°C)	PTC 热敏电阻在达到某一温度前，电阻值是恒定的，一旦超过这一温度，电阻值也会急剧上升。这一电阻值的变化点成为“居里点（也称为居里温度）”，即 25℃时电阻值的 2 倍电阻值所处的温度。 The resistance of the PTC Thermistor remains almost constant up to a certain temperature, and the resistance suddenly increases after a certain temperature. The changing point of this resistance is called the "Curie point (Curie temperature)", and we define this point as the temperature where the resistance becomes double of the resistance at 25°C.

6 信赖性试验 Reliability Test

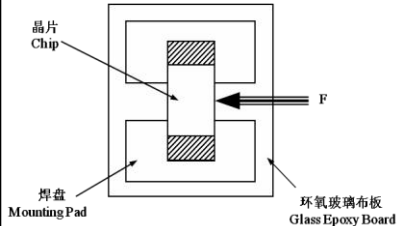
项目 Items	测试标准 Standard	测试方法及备注 Test Methods and Remarks	要求 Requirements								
端头附着力 Terminal Strength	IEC 60068-2-21	将晶片焊接在测试基板上（如右图所示的环氧玻璃布板），按箭头所示方向施加作用力。 Solder the chip to the testing jig (glass epoxy board shown in the right) using eutectic solder. Then apply a force in the direction of the arrow. <table border="1" style="margin: 10px auto;"> <thead> <tr> <th>尺寸 Size</th> <th>F</th> <th>保持时间 Duration</th> </tr> </thead> <tbody> <tr> <td>0603</td> <td>5N</td> <td rowspan="2">10±1s</td> </tr> <tr> <td>0805</td> <td>5N</td> </tr> </tbody> </table>	尺寸 Size	F	保持时间 Duration	0603	5N	10±1s	0805	5N	端电极无脱落且瓷体无损伤。 No removal or split of the termination or other defects shall occur. 
尺寸 Size	F	保持时间 Duration									
0603	5N	10±1s									
0805	5N										

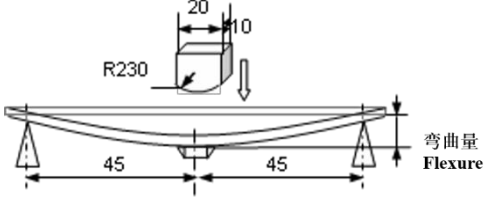
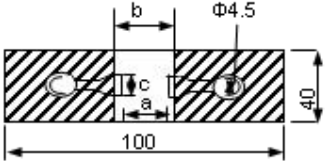
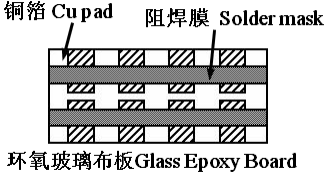
<p>抗弯强度 Resistance to Flexure</p>	<p>IEC 60068-2-21</p>	<p>将晶片焊接在测试基板上（如右图所示的环氧玻璃布板），按下图箭头所示方向施加作用力。</p> <p>Solder the chip to the test jig (glass epoxy board shown in the right) using a eutectic solder. Then apply a force in the direction shown as follow.</p>  <table border="1" data-bbox="445 573 1086 745"> <thead> <tr> <th>尺寸 Size</th> <th>弯曲变形量 Flexure</th> <th>施压速度 Pressurizing Speed</th> <th>保持时间 Duration</th> </tr> </thead> <tbody> <tr> <td>0603,0805</td> <td>2mm</td> <td><0.5mm/s</td> <td>10±1s</td> </tr> </tbody> </table>	尺寸 Size	弯曲变形量 Flexure	施压速度 Pressurizing Speed	保持时间 Duration	0603,0805	2mm	<0.5mm/s	10±1s	<p>① 无外观损伤。 No visible damage.</p> <p>② $\Delta R_{25}/R_{25} \leq 20\%$</p> <p>单位 unit: mm</p> <table border="1" data-bbox="1155 327 1517 461"> <thead> <tr> <th>类型 Type</th> <th>a</th> <th>b</th> <th>c</th> </tr> </thead> <tbody> <tr> <td>0603</td> <td>1.0</td> <td>3.0</td> <td>1.2</td> </tr> <tr> <td>0805</td> <td>1.2</td> <td>4.0</td> <td>1.65</td> </tr> </tbody> </table> 	类型 Type	a	b	c	0603	1.0	3.0	1.2	0805	1.2	4.0	1.65
尺寸 Size	弯曲变形量 Flexure	施压速度 Pressurizing Speed	保持时间 Duration																				
0603,0805	2mm	<0.5mm/s	10±1s																				
类型 Type	a	b	c																				
0603	1.0	3.0	1.2																				
0805	1.2	4.0	1.65																				
<p>振动 Vibration</p>	<p>IEC 60068-2-80</p>	<p>① 将晶片焊接在测试基板上（如右图所示的环氧玻璃布板）； Solder the chip to the testing jig (glass epoxy board shown in the left) using eutectic solder.</p> <p>② 晶片以全振幅为 1.5mm 进行振动，频率范围为 10Hz ~55 Hz； The chip shall be subjected to a simple harmonic motion having total amplitude of 1.5mm, the frequency being varied uniformly between the approximate limits of 10 and 55 Hz.</p> <p>③ 振动频率按 10Hz→55Hz→10Hz 循环，周期为 1 分钟，在空间三个互相垂直的方向上各振动 2 小时（共 6 小时）。 The frequency ranges from 10 to 55 Hz and return to 10 Hz shall be traversed in approximately 1 minute. This motion shall be applied for a period of 2 hours in each 3 mutually perpendicular directions (total of 6 hours).</p>	<p>无外观损伤。 No visible damage.</p> 																				
<p>坠落 Dropping</p>	<p>IEC 60068-2-32</p>	<p>从 1m 的高度让晶片自由坠落至水泥地面 10 次。 Drop a chip 10 times on a concrete floor from a height of 1 meter.</p>	<p>无外观损伤。 No visible damage.</p>																				
<p>可焊性 Solderability</p>	<p>IEC 60068-2-58</p>	<p>① 焊接温度 Solder temperature: 245±5 °C. ② 浸渍时间 Duration: 3±0.3s. ③ 焊锡成分 Solder: 96.5Sn/3.0Ag/0.5Cu. ④ 助焊剂 Flux: （重量比）25%松香和 75%酒精 25% Resin and 75% ethanol in weight.</p>	<p>① 无外观损伤； No visible damage.</p> <p>② 元件端电极的焊锡覆盖率不小于 95%。 Wetting shall exceed 95% coverage.</p>																				
<p>耐焊性 Resistance to Soldering Heat</p>	<p>IEC 60068-2-58</p>	<p>① 预热 Preheat: 150±5°C , 90~120 s. ② 焊接温度 Solder temperature: 260±5°C. ③ 浸渍时间 Duration: 10±1s. ④ 焊锡成分 Solder: 96.5Sn/3.0Ag/0.5Cu. ⑤ 助焊剂 Flux: （重量比）25%松香和 75%酒精 25% Resin and 75% ethanol in weight.</p>	<p>① 无外观损伤； No visible damage.</p> <p>② $\Delta R_{25}/R_{25} \leq 20\%$</p>																				

温度周期 Temperature cycling	IEC 60068-2-14	<p>① 将晶片焊接在测试基板上, Solder the chip to the testing jig (glass epoxy board shown in the left) using eutectic solder,</p> <p>② 于下表所示的环境条件下重复 5 次, 5 cycles of following sequence without loading.</p> <table border="1"> <thead> <tr> <th>步骤 Step</th> <th>温度 Temperature</th> <th>时间 Time</th> </tr> </thead> <tbody> <tr> <td>1</td> <td>-20±3℃</td> <td>30min</td> </tr> <tr> <td>2</td> <td>125±2℃</td> <td>30min</td> </tr> </tbody> </table> <p>③ 转换时间 Conversion time: <10 s。</p>	步骤 Step	温度 Temperature	时间 Time	1	-20±3℃	30min	2	125±2℃	30min	<p>① 无外观损伤; No visible damage.</p> <p>② $\Delta R_{25}/R_{25} \leq 20\%$</p>
步骤 Step	温度 Temperature	时间 Time										
1	-20±3℃	30min										
2	125±2℃	30min										
高温存放 Resistance to dry heat	IEC 60068-2-2	<p>① 将晶片焊接在测试基板上, Solder the chip to the testing jig (glass epoxy board shown in the left) using eutectic solder,</p> <p>② 150±2℃ ,</p> <p>③ 1000+48/-0 小时 hours。</p>	<p>① 无外观损伤; No visible damage.</p> <p>② $\Delta R_{25}/R_{25} \leq 20\%$</p>									
低温存放 Resistance to cold	IEC 60068-2-1	<p>① 将晶片焊接在测试基板上, Solder the chip to the testing jig (glass epoxy board shown in the left) using eutectic solder,</p> <p>② -20±3℃ ,</p> <p>③ 1000+48/-0 小时 hours。</p>	<p>① 无外观损伤; No visible damage.</p> <p>② $\Delta R_{25}/R_{25} \leq 20\%$</p>									
湿热存放 Resistance to damp heat	IEC 60068-2-67	<p>① 将晶片焊接在测试基板上, Solder the chip to the testing jig (glass epoxy board shown in the left) using eutectic solder.</p> <p>② 在 40±2℃, 相对湿度 90±5%环境中, In an environment of 40±2℃ and relative humidity of 90±5%,</p> <p>③ 500+24/-0 小时 hours。</p>	<p>① 无外观损伤; No visible damage.</p> <p>② $\Delta R_{25}/R_{25} \leq 20\%$</p>									
高温负荷 Resistance to high temperature load	IEC 60068-2-2	<p>① 将晶片焊接在测试基板上, Solder the chip to the testing jig (glass epoxy board shown in the left) using eutectic solder.</p> <p>② 在 85±2℃空气中, 施加最高电压 1000±48 小时。 In 85±2℃ air, apply the highest voltage for 1000±48 hours.</p>	<p>① 无外观损伤; No visible damage.</p> <p>② $\Delta R_{25}/R_{25} \leq 20\%$</p>									

7 编带 Taping

类型 Type	0603	0805
编带厚度 Tape thickness(mm)	0.8±0.15	0.85±0.2
编带材质 Tape material	纸带 Paper Tape	
每盘数量 Quantity per Reel	4K	4K

(1) 编带图 Taping Drawings

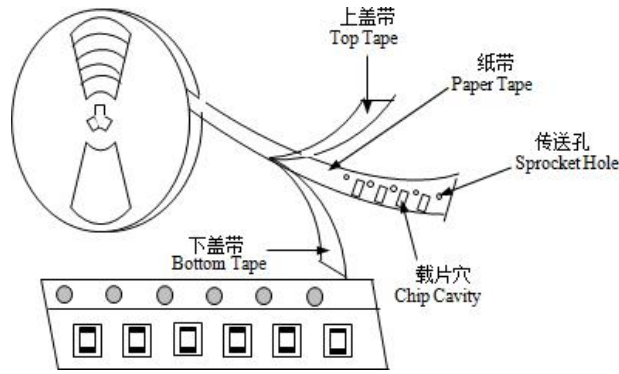

(2) 纸带尺寸 Paper Tape Dimensions (单位 Unit: mm)

YFT0603 系列 YFT0603 series

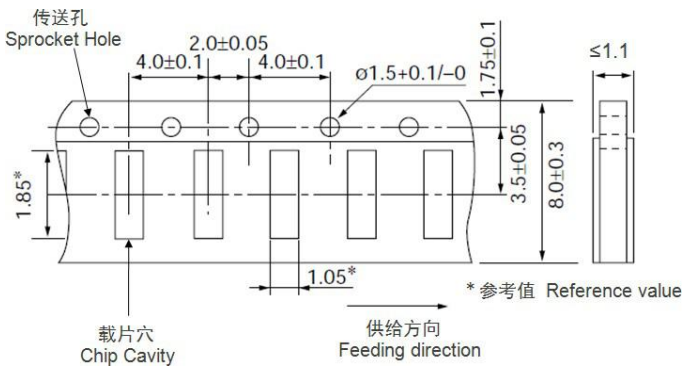

YFT0805 系列 YFT0805 series

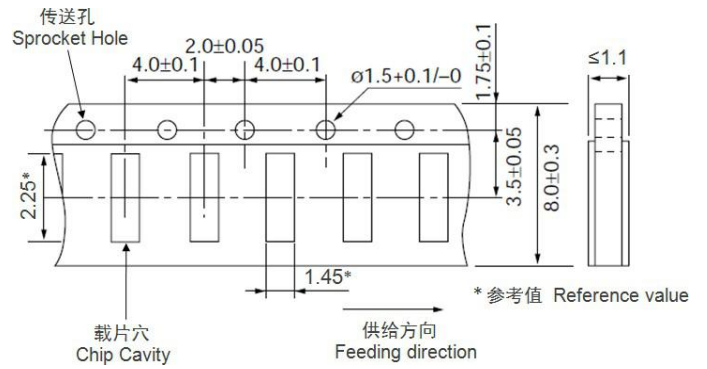

(3) 卷盘尺寸 Reel Dimensions (单位 Unit: mm)

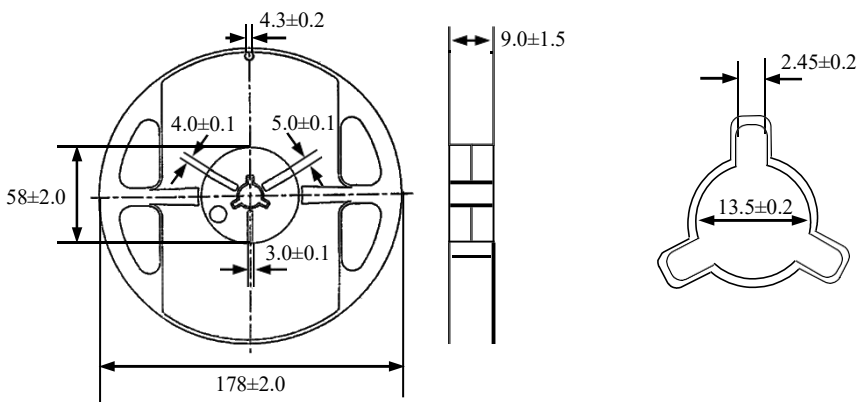

8 储存**- 储存条件**

- a. 储存温度: $-10^{\circ}\text{C} \sim 40^{\circ}\text{C}$
- b. 相对湿度: $\leq 75\% \text{RH}$
- c. 避免接触粉尘、腐蚀性气氛和阳光

- 储存期限: 产品交付后 6 个月**9 注意事项****- YFT系列热敏电阻不可在以下条件下工作或储存:**

- (1) 腐蚀性气体或还原性气体
(氯气、硫化氢气体、氨气、硫酸气体、一氧化氮等)。
- (2) 挥发性或易燃性气体
- (3) 多尘条件
- (4) 高压或低压条件
- (5) 潮湿场所
- (6) 存在盐水、油、化学液体或有机溶剂的场所
- (7) 强烈振动
- (8) 存在类似有害条件的其他场所

- YFT系列热敏电阻的陶瓷属于易碎材料, 使用时不可施加过大压力或冲击。**- YFT系列热敏电阻不可在超过目录规定的温度范围情况下工作。****8 Storage****- Storage Conditions**

- a. Storage Temperature: $-10^{\circ}\text{C} \sim 40^{\circ}\text{C}$
- b. Relative Humidity: $\leq 75\% \text{RH}$
- c. Keep away from corrosive atmosphere and sunlight.

- Period of Storage: 6 Months after delivery**9 Notes & Warnings****- The YFTseries thermistors shall not be operated and stored under the following environmental condition:**

- (1) Corrosive or deoxidized atmospheres
(such as chlorine, sulfurated hydrogen, ammonia, sulfuric acid, nitric oxide and so on)
- (2) Volatile or inflammable atmospheres
- (3) Dusty condition
- (4) Excessively high or low pressure condition
- (5) Humid site
- (6) Places with brine, oil, chemical liquid or organic solvent
- (7) Intense vibration
- (8) Places with analogously deleterious conditions

- The ceramic body of the YFTseries thermistors is fragile, no excessive pressure or impact shall be exerted on it.**- The YFTseries thermistors shall not be operated beyond the specified "Operating Temperature Range" in the catalog.**

10 建议焊接条件

- 回流焊

- 温升 1~2°C/sec.
- 预热: 150~170°C/90±30 sec.
- 大于 240°C时间: 20~40sec
- 峰值温度: 最高 260°C/10 sec.
- 焊锡: 96.5Sn/3.0Ag/0.5Cu
- 回流焊: 最多 2 次

10 Recommended Soldering Technologies

- Re-flowing Profile

- 1~2°C/sec. Ramp
- Pre-heating: 150~170°C/90±30 sec.
- Time above 240°C: 20~40 sec.
- Peak temperature: 260°CMax./10 sec.
- Solder paste: 96.5Sn/3.0Ag/0.5Cu
- Max.2 times for re-flowing

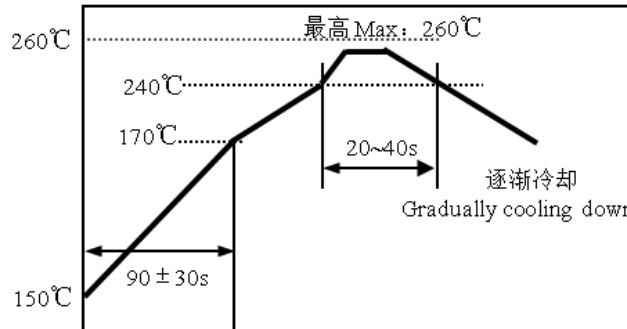

- 波峰焊

- 温升 1~2°C/sec.
- 预热: 140~160°C/60~120 sec.
- 焊接温度: 最高 250°C/3 sec.
- 焊锡: 96.5Sn/3.0Ag/0.5Cu
- 波峰焊: 最多 2 次

- Flow Soldering

- 1~2°C/sec. Ramp
- Pre-heating: 140~160°C/60~120 sec.
- Welding temperature: 250°CMax./3 sec.
- Solder paste: 96.5Sn/3.0Ag/0.5Cu
- Max.2 times for flow soldering

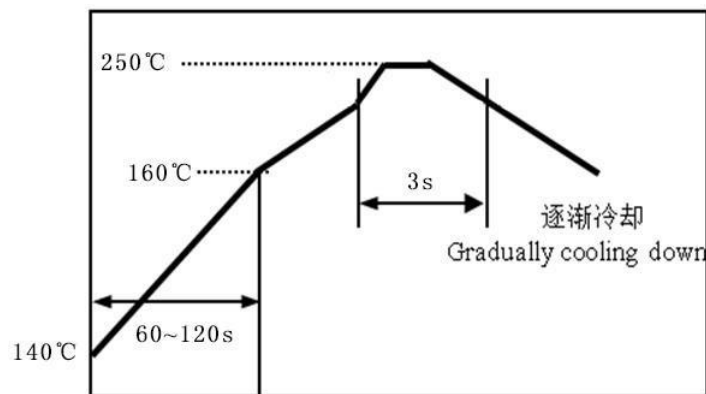

- 手工焊

- 烙铁功率: 最大 20W
- 预热: 150°C/60sec.
- 烙铁头温度: 最高 280°C
- 焊接时间: 最多 3sec.
- 焊锡: 96.5Sn/3.0Ag/0.5Cu
- 手工焊: 最多 1 次

- Iron Soldering Profile

- Iron soldering power: Max.20W
- Pre-heating: 150°C/60sec.
- Soldering Tip temperature: 280°C Max.
- Soldering time: 3 sec Max.
- Solder paste: 96.5Sn/3.0Ag/0.5Cu
- Max.1 times for iron soldering

[注: 不要使烙铁头接触到端头]

[Note: Take care not to apply the tip of the soldering iron to the terminal electrodes.]

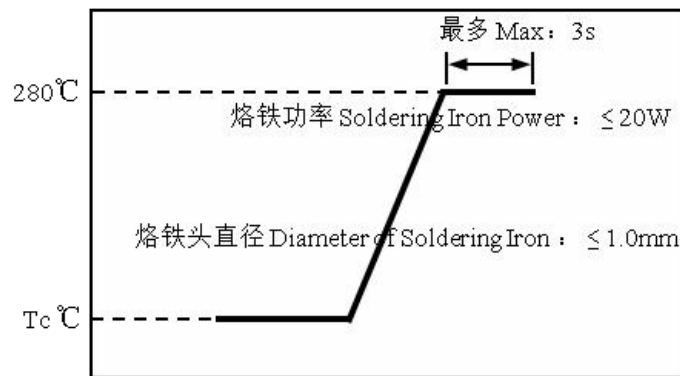

11 R-T 曲线 (典型) R-T curve (typical)

