

广东济德精密电子有限公司
受控文件
 日期: 2021年10月19日

REV	DESCRIPTION	DESIGN	APPROVAL	DATE
A0	NEW VERSION	Colinye	Jerry	

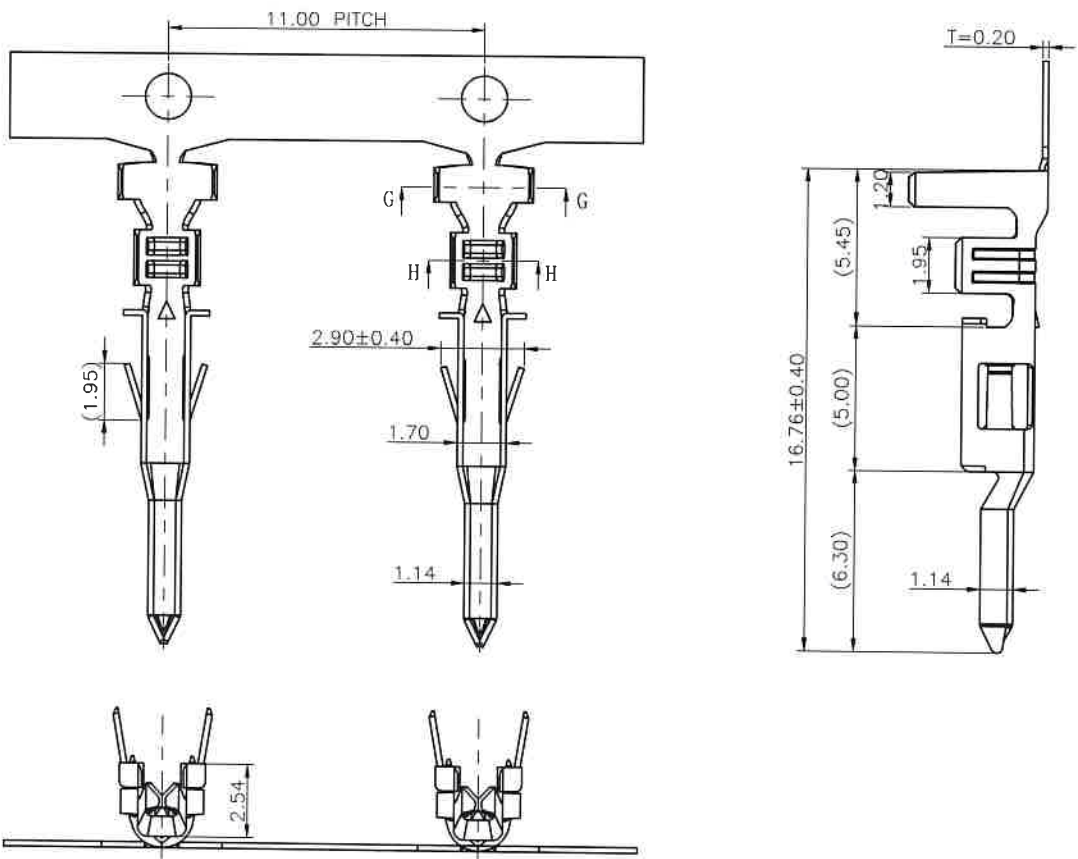
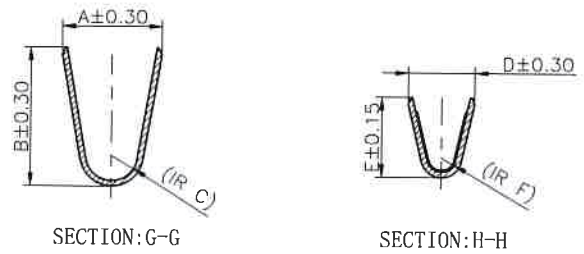

- NOTES:
1. Material/材质: See Table-1/见表-1;
 2. Finish/表面处理: Tin Plating/镀锡
 3. Contact Surface Should Not Have Burrs;
Other Areas Burrs 0.05mm Max.
接触部位不能有毛边, 其它部位0.05mm Max;
 4. Never Piff The Black, White Fog, Crushed Phenomenon;
不能存在发黑, 发白, 压伤现象;
 5. Harmful Material Please Follow RoHS.
有害物质管控符合RoHS.
 6. Order Information/编码原则: 932-114-101X
See Table/见表-1

Table-1

P/N	A	B	C	D	F	F	Material/材质	Wire Size Range/线径
932-114-1011	3.60	4.50	0.90	1.90	2.30	0.50	Brass/黄铜	AWG18~AWG24
932-114-1012	3.60	4.50	0.90	1.90	2.30	0.50	Phosphor bronze/磷铜	AWG18~AWG24
932-114-1013	2.30	2.30	0.60	1.80	1.65	0.40	Brass/黄铜	AWG22~AWG28
932-114-1014	2.30	2.30	0.60	1.80	1.65	0.40	Phosphor bronze/磷铜	AWG22~AWG28
932-114-1015	3.60	4.50	0.90	2.30	2.70	0.60	Brass/黄铜	AWG16
932-114-1016	3.60	4.50	0.90	2.30	2.70	0.60	Phosphor bronze/磷铜	AWG16

X.± 0.50	X.*± 1"
.X± 0.30	.X*± 0.5"
.XX± 0.20	.XX*± /
.XXX± 0.10	.XXX*± /
UNITS:	mm

The information in this document is property of JIDC company and should not be copied or reproduced in any other way, without written permission.

JIDC Guangdong JiDe Precision Electronics Co., Ltd
 广东济德精密电子有限公司

TITLE: 4.20 mm Male Terminal

PART NO. 932-114-101X

DWG NO. C-932-114-101X

APPD: Jerry

CHKD: Ray

DRAW: Colinye

SCALE	SHEET	REV.
4:1	1/1	A0

E
D
C
B
A

E
D
C
B
A