

REV	DESCRIPTION	DESIGN	APPROVAL	DATE
AO	NEW VERSION	Colinye	Jerry	

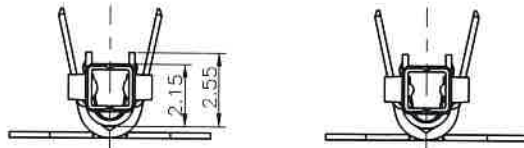
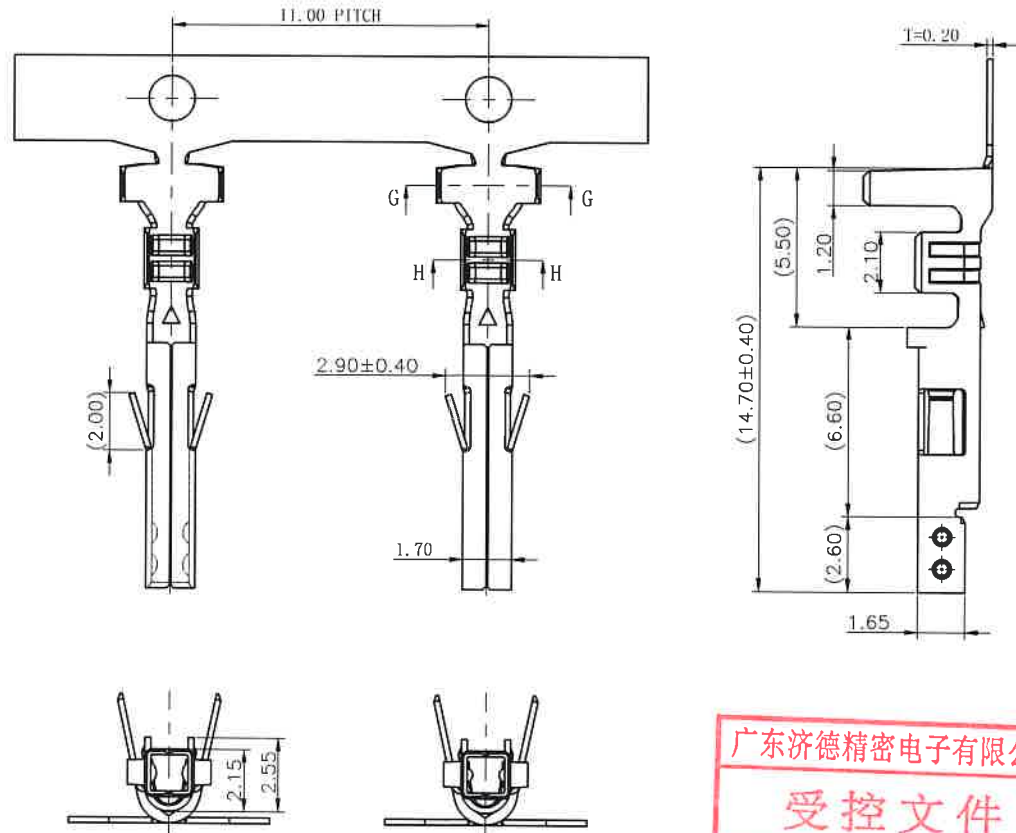
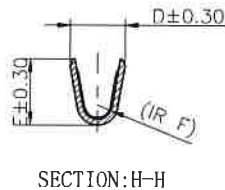
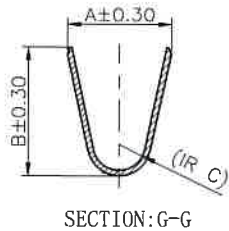

CONTACT DIMPLE CONFIGURATIONS
接触点配置

广东济德精密电子有限公司
 受控文件
 日期: 2021年10月19日

NOTES:

1. Material/材质: See table-1/见表-1;
2. Finish/表面处理: Tin Plating/镀锡
3. Contact Surface Should Not Have Burrs;
Other Areas Burrs 0.05mm Max.
接触部位不能有毛边, 其它部位0.05mm Max;
4. Never Pff The Black, White Fog, Crushed Phenomenon;
不能存在发黑, 发白, 压伤现象;
5. Harmful Material Please Follow RoHS.
有害物质管控符合RoHS.
6. Order Information/编码原则: 922-114-101X -X

- X: N/A: Large contact dimple
大接触点
- 2: Small contact dimple
小接触点
- See Table-1/见表-1

Table-1

P/N	A	B	C	D	E	F	Material/材质	Wire Size Range/线径
922-114-1011	3.60	4.50	0.90	1.90	2.30	0.50	Brass/黄铜	AWG18~AWG24
922-114-1012	3.60	4.50	0.90	1.90	2.30	0.50	Phosphor bronze/磷铜	AWG18~AWG24
922-114-1013	2.30	2.30	0.60	1.80	1.65	0.40	Brass/黄铜	AWG22~AWG28
922-114-1014	2.30	2.30	0.60	1.80	1.65	0.40	Phosphor bronze/磷铜	AWG22~AWG28
922-114-1015	3.60	4.50	0.90	2.30	2.70	0.60	Brass/黄铜	AWG16
922-114-1016	3.60	4.50	0.90	2.30	2.70	0.60	Phosphor bronze/磷铜	AWG16

X.± 0.50	X.'± 1'
.X± 0.30	.X'± 0.5'
.XX± 0.20	.XX'± /
.XXX± 0.10	.XXX'± /
UNITS:	mm



Guangdong JiDe Precision Electronics Co., Ltd
广东济德精密电子有限公司

The information in this document is property of JIDC company and should not be copied or reproduced in any other way, without written permission.

TITLE:
4.20 mm Female Terminal

PART NO.
922-114-101X

APPD: *Jerry*

DWG NO:
C-922-114-101X

CHKD: *Roy*

DRAW: *Colinye*

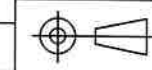

SCALE	SHEET	REV.
4:1	1/1	AO