

Key Features

- SMPTE 292M and SMPTE 259M-C compliant scrambling and NRZ → NRZI encoding (with bypass)
- DVB-ASI sync word insertion and 8b/10b encoding
- User selectable additional processing features including:
 - CRC, ANC data checksum, and line number calculation and insertion
 - TRS and EDH packet generation and insertion
 - illegal code remapping
- Internal flywheel for noise immune TRS generation
- 20-bit / 10-bit CMOS parallel input data bus
- 148.5MHz / 74.25MHz / 27MHz / 13.5MHz parallel digital input
- Automatic standards detection and indication
- Pb-free and RoHS Compliant
- 1.8V core power supply and 3.3V charge pump power supply
- 3.3V digital I/O supply
- JTAG test interface
- Small footprint compatible with GS1560A, GS1561, GS9060, and GS9062

Applications

- SMPTE 292M Serial Digital Interfaces
- SMPTE 259M-C Serial Digital Interfaces
- DVB-ASI Serial Digital Interfaces

Description

The GS1532 is a multi-standard serializer with an integrated cable driver. When used in conjunction with the GO1555/GO1525* Voltage Controlled Oscillator, a transmit solution can be realized for HD-SDI, SD-SDI and DVB-ASI applications.

The device features an internal PLL, which can be configured for loop bandwidth as narrow as 100kHz. Thus the GS1532 can tolerate in excess of 300ps jitter on the input PCLK and still provide output jitter well within SMPTE specification. Connect the output clocks from Gennum's GS4911 clock generator directly to the GS1532's PCLK input and configure the GS1532's loop bandwidth accordingly.

In addition to serializing the input, the GS1532 performs NRZ-to-NRZI encoding and scrambling as per SMPTE 292M/259M-C when operating in SMPTE mode. When operating in DVB-ASI mode, the device will insert K28.5 sync characters and 8b/10b encode the data prior to serialization.

Parallel data inputs are provided for 10-bit multiplexed or 20-bit demultiplexed formats at both HD and SD signal rates. An appropriate parallel clock input signal is also required.

The integrated cable driver features an output mute on loss of parallel clock, high impedance mode, adjustable signal swing, and automatic dual slew rate selection depending on HD/SD operational requirements.

The GS1532 also includes a range of data processing functions including automatic standards detection and EDH support. The device can also insert TRS signals, calculate and insert line numbers and CRC's, re-map illegal code words and insert SMPTE 352M payload identifier packets. All processing features are optional and may be enabled/disabled via external control pin(s) and/or host interface programming.

The GS1532 is Pb-free, and the encapsulation compound does not contain halogenated flame retardant.

This component and all homogeneous subcomponents are RoHS compliant.

*For new designs use GO1555

Functional Block Diagram

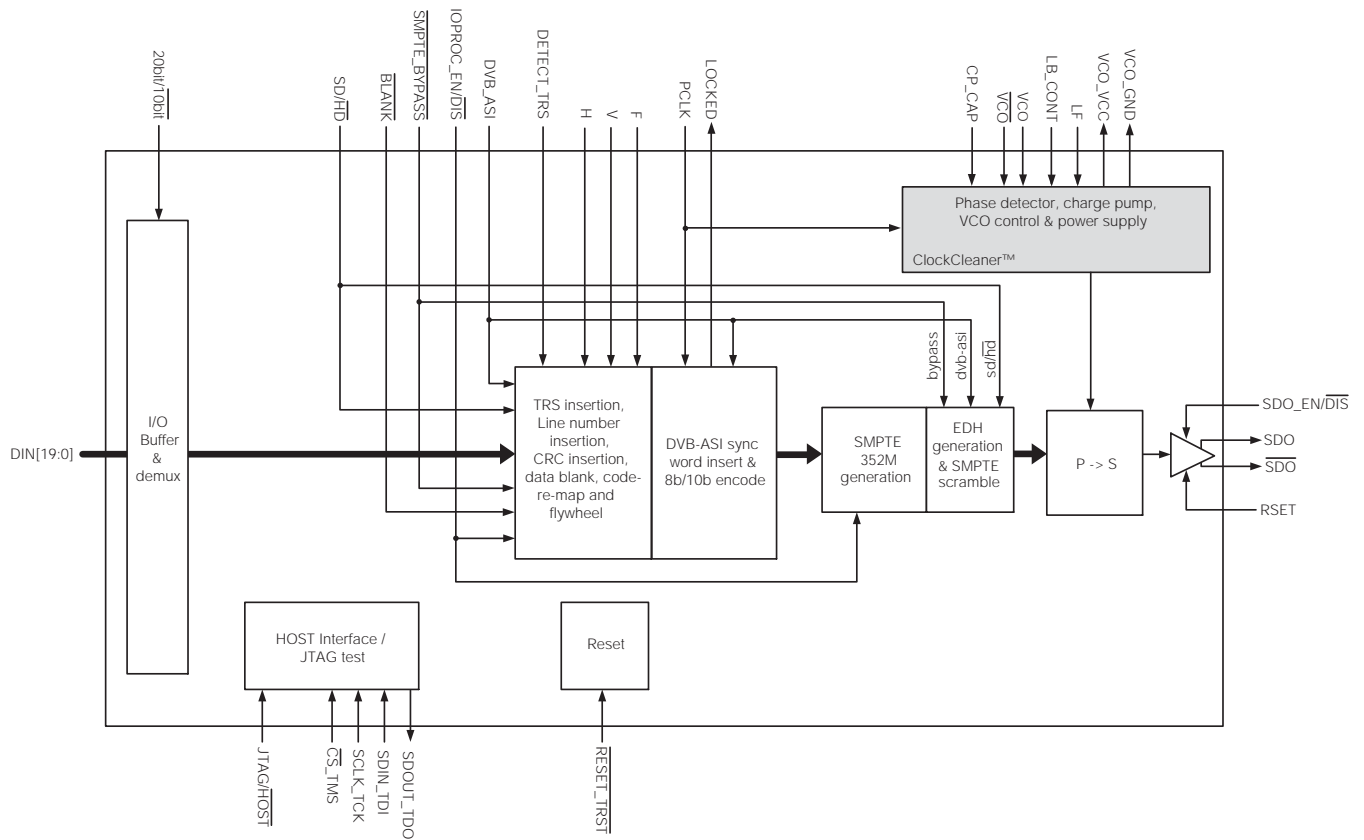

GS1532 Functional Block Diagram

Contents

Key Features	1
Applications	1
Description	1
Functional Block Diagram	2
1. Pin Out	5
1.1 Pin Assignment	5
1.2 Pin Descriptions	6
2. Electrical Characteristics	14
2.1 Absolute Maximum Ratings	14
2.2 DC Electrical Characteristics	14
2.3 AC Electrical Characteristics	16
2.4 Solder Reflow Profiles	18
2.5 Input/Output Circuits	19
2.6 Host Interface Maps	21
2.6.1 Host Interface Map (Read Only Registers)	22
2.6.2 Host Interface Map (R/W Configurable Registers)	23
3. Detailed Description	24
3.1 Functional Overview	24
3.2 Parallel Data Inputs	24
3.2.1 Parallel Input in SMPTE Mode	25
3.2.2 Parallel Input in DVB-ASI Mode	25
3.2.3 Parallel Input in Data-Through Mode	25
3.2.4 Parallel Input Clock (PCLK)	26
3.3 SMPTE Mode	27
3.3.1 Internal Flywheel	27
3.3.2 HVF Timing Signal Extraction	27
3.4 DVB-ASI mode	29
3.4.1 Control Signal Inputs	29
3.5 Data-Through Mode	29
3.6 Additional Processing Functions	30
3.6.1 Input Data Blank	30
3.6.2 Automatic Video Standard Detection	30
3.6.3 Packet Generation and Insertion	32
3.7 Parallel-To-Serial Conversion	39
3.8 Serial Digital Data PLL	40
3.8.1 External VCO	40
3.8.2 Lock Detect Output	40
3.8.3 Loop Bandwidth Adjustment	41
3.9 Serial Digital Output	41
3.9.1 Output Swing	42

3.9.2 Serial Digital Output Mute	42
3.10 GSPI Host Interface	42
3.10.1 Command Word Description	43
3.10.2 Data Read and Write Timing	44
3.10.3 Configuration and Status Registers	45
3.11 JTAG	45
3.12 Device Power Up	47
3.13 Device Reset	47
4. Application Reference Design	48
4.1 Typical Application Circuit	48
5. References & Relevant Standards	49
6. Package & Ordering Information	50
6.1 Package Dimensions	50
6.2 Packaging Data	51
6.3 Ordering Information	51
7. Revision History	52

1. Pin Out

1.1 Pin Assignment

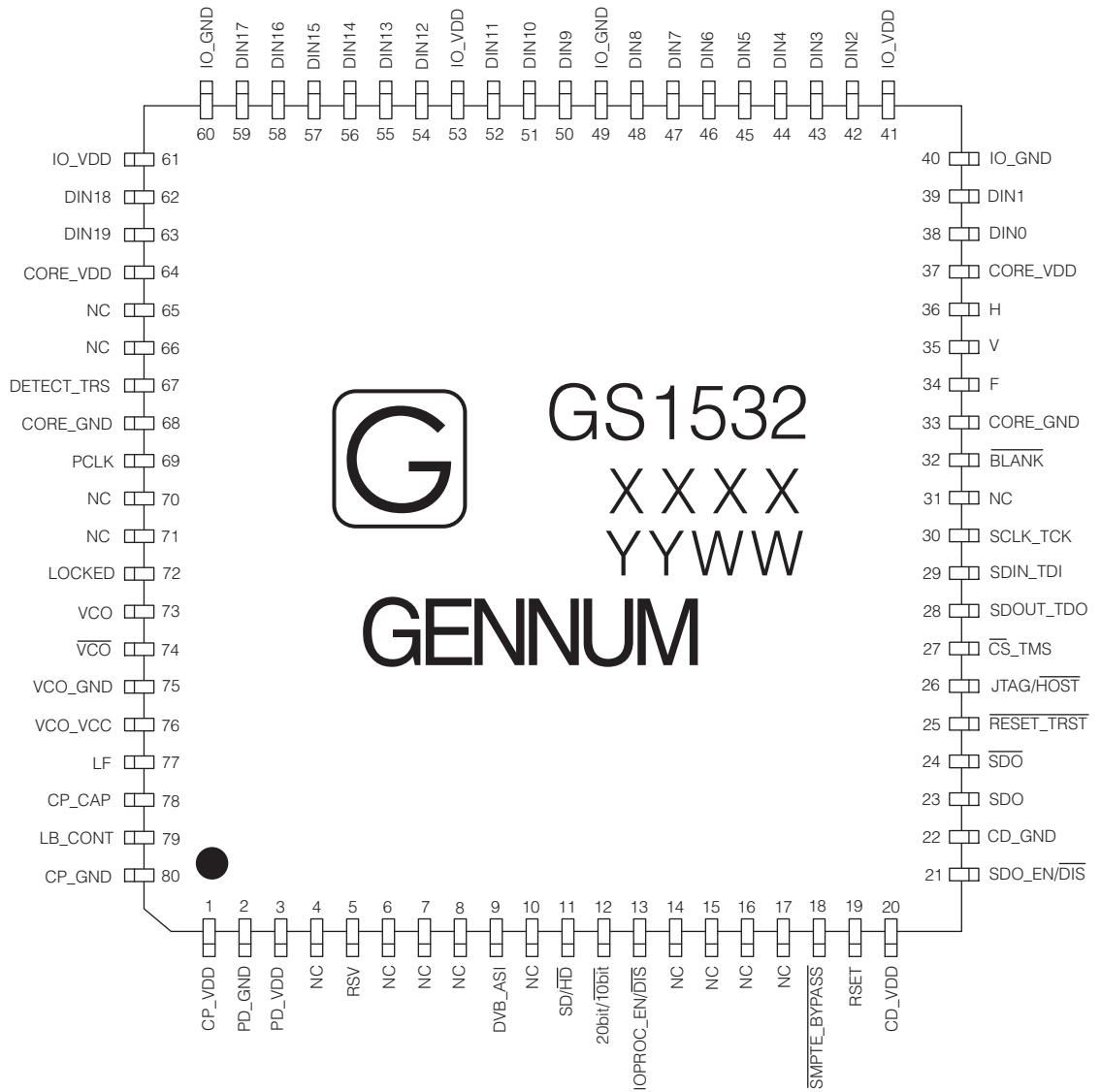

1.2 Pin Descriptions

Table 1-1: Pin Descriptions

Pin Number	Name	Timing	Type	Description
1	CP_VDD	–	Power	Power supply connection for the charge pump. Connect to +3.3V DC analog.
2	PD_GND	–	Power	Ground connection for the phase detector. Connect to analog GND.
3	PD_VDD	–	Power	Power supply connection for the phase detector. Connect to +1.8V DC analog.
4, 6-8, 10, 14-17, 31, 65, 66, 70, 71	NC	–	–	No connect.
5	RSV	–	–	Reserved. Connect to Analog GND.
9	DVB_ASI	Non Synchronous	Input	CONTROL SIGNAL INPUT Signal levels are LVCMOS/LVTTL compatible. When set HIGH in conjunction with $\overline{SD/HD}$ = HIGH and $\overline{SMPTE_BYPASS}$ = LOW, the device will be configured to operate in DVB-ASI mode. When set LOW, the device will not support the encoding of received DVB-ASI data.
11	$\overline{SD/HD}$	Non Synchronous	Input	CONTROL SIGNAL INPUT Signal levels are LVCMOS/LVTTL compatible. When set LOW, the device will be configured to transmit signal rates of 1.485Gb/s or 1.485/1.001Gb/s only. When set HIGH, the device will be configured to transmit signal rates of 270Mb/s only.
12	20bit/ $\overline{10bit}$	Non Synchronous	Input	CONTROL SIGNAL INPUT Signal levels are LVCMOS/LVTTL compatible. Used to select the input data bus width in SMPTE or Data-Through modes. This signal is ignored in DVB-ASI mode. When set HIGH, the parallel input will be 20-bit demultiplexed data. When set LOW, the parallel input will be 10-bit multiplexed data.

Table 1-1: Pin Descriptions (Continued)

Pin Number	Name	Timing	Type	Description
13	IOPROC_EN $\overline{\text{DIS}}$	Non Synchronous	Input	<p>CONTROL SIGNAL INPUT Signal levels are LVCMOS/LVTTL compatible. Used to enable or disable I/O processing features. When set HIGH, the following I/O processing features of the device are enabled:</p> <ul style="list-style-type: none"> • EDH Packet Generation and Insertion (SD-only) • SMPTE 352M Packet Generation and Insertion • ANC Data Checksum Calculation and Insertion • Line-based CRC Generation and Insertion (HD-only) • Line Number Generation and Insertion (HD-only) • TRS Generation and Insertion • Illegal Code Remapping <p>To enable a subset of these features, keep IOPROC_EN$\overline{\text{DIS}}$ HIGH and disable the individual feature(s) in the IOPROC_DISABLE register accessible via the host interface. When set LOW, the I/O processing features of the device are disabled, regardless of whether the features are enabled in the IOPROC_DISABLE register.</p>
18	$\overline{\text{SMPTE_BYPASS}}$	Non Synchronous	Input	<p>CONTROL SIGNAL INPUT Signal levels are LVCMOS/LVTTL compatible. When set HIGH in conjunction with DVB_ASI = LOW, the device will be configured to operate in SMPTE mode. All I/O processing features may be enabled in this mode. When set LOW, the device will not support the scrambling or encoding of received SMPTE data. No I/O processing features will be available.</p>
19	RSET	Analog	Input	Used to set the serial digital output signal amplitude. Connect to CD_VDD through 281 Ω +/- 1% for 800mV _{p-p} single-ended output swing.
20	CD_VDD	–	Power	Power supply connection for the serial digital cable driver. Connect to +1.8V DC analog.
21	SDO_EN $\overline{\text{DIS}}$	Non Synchronous	Input	<p>CONTROL SIGNAL INPUT Signal levels are LVCMOS/LVTTL compatible. Used to enable or disable the serial digital output stage. When set LOW, the serial digital output signals SDO and $\overline{\text{SDO}}$ are disabled and become high impedance. When set HIGH, the serial digital output signals SDO and $\overline{\text{SDO}}$ are enabled.</p>
22	CD_GND	–	Power	Ground connection for the serial digital cable driver. Connect to analog GND.
23, 24	SDO, $\overline{\text{SDO}}$	Analog	Output	<p>Serial digital output signal operating at 1.485Gb/s, 1.485/1.001Gb/s, or 270Mb/s. The slew rate of these outputs is automatically controlled to meet SMPTE 292M and 259M specifications according to the setting of the SD/HD pin.</p>

Table 1-1: Pin Descriptions (Continued)

Pin Number	Name	Timing	Type	Description
25	$\overline{\text{RESET_TRST}}$	Non Synchronous	Input	<p>CONTROL SIGNAL INPUT Signal levels are LVCMOS/LVTTL compatible.</p> <p>Used to reset the internal operating conditions to default settings and to reset the JTAG test sequence.</p> <p>Host Mode (JTAG/$\overline{\text{HOST}}$ = LOW) When asserted LOW, all functional blocks will be set to default conditions and all input and output signals become high impedance, including the serial digital outputs SDO and SDO.</p> <p>Must be set HIGH for normal device operation.</p> <p>JTAG Test Mode (JTAG/$\overline{\text{HOST}}$ = HIGH) When asserted LOW, all functional blocks will be set to default and the JTAG test sequence will be held in reset.</p> <p>When set HIGH, normal operation of the JTAG test sequence resumes.</p>
26	JTAG/ $\overline{\text{HOST}}$	Non Synchronous	Input	<p>CONTROL SIGNAL INPUT Signal levels are LVCMOS/LVTTL compatible.</p> <p>Used to select JTAG Test Mode or Host Interface Mode.</p> <p>When set HIGH, $\overline{\text{CS_TMS}}$, SDOUT_TDO, SDI_TDI and SCLK_TCK are configured for JTAG boundary scan testing.</p> <p>When set LOW, $\overline{\text{CS_TMS}}$, SDOUT_TDO, SDI_TDI and SCLK_TCK are configured as GSPI pins for normal host interface operation.</p>
27	$\overline{\text{CS_TMS}}$	Synchronous with SCLK_TCK	Input	<p>CONTROL SIGNAL INPUT Signal levels are LVCMOS/LVTTL compatible.</p> <p>Chip Select / Test Mode Select</p> <p>Host Mode (JTAG/$\overline{\text{HOST}}$ = LOW) $\overline{\text{CS_TMS}}$ operates as the host interface chip select, $\overline{\text{CS}}$, and is active LOW.</p> <p>JTAG Test Mode (JTAG/$\overline{\text{HOST}}$ = HIGH) $\overline{\text{CS_TMS}}$ operates as the JTAG test mode select, TMS, and is active HIGH.</p> <p>NOTE: If the host interface is not being used, tie this pin HIGH.</p>
28	SDOUT_TDO	Synchronous with SCLK_TCK	Output	<p>CONTROL SIGNAL OUTPUT Signal levels are LVCMOS/LVTTL compatible.</p> <p>Serial Data Output / Test Data Output</p> <p>Host Mode (JTAG/$\overline{\text{HOST}}$ = LOW) SDOUT_TDO operates as the host interface serial output, SDOUT, used to read status and configuration information from the internal registers of the device.</p> <p>JTAG Test Mode (JTAG/$\overline{\text{HOST}}$ = HIGH) SDOUT_TDO operates as the JTAG test data output, TDO.</p>

Table 1-1: Pin Descriptions (Continued)

Pin Number	Name	Timing	Type	Description
29	SDIN_TDI	Synchronous with SCLK_TCK	Input	<p>CONTROL SIGNAL INPUT Signal levels are LVCMOS/LVTTL compatible.</p> <p>Serial Data In / Test Data Input Host Mode (JTAG/$\overline{\text{HOST}}$ = LOW) SDIN_TDI operates as the host interface serial input, SDIN, used to write address and configuration information to the internal registers of the device.</p> <p>JTAG Test Mode (JTAG/$\overline{\text{HOST}}$ = HIGH) SDIN_TDI operates as the JTAG test data input, TDI. NOTE: If the host interface is not being used, tie this pin HIGH.</p>
30	SCLK_TCK	Non Synchronous	Input	<p>CONTROL SIGNAL INPUT Signal levels are LVCMOS/LVTTL compatible.</p> <p>Serial Data Clock / Test Clock. Host Mode (JTAG/$\overline{\text{HOST}}$ = LOW) SCLK_TCK operates as the host interface burst clock, SCLK. Command and data read/write words are clocked into the device synchronously with this clock.</p> <p>JTAG Test Mode (JTAG/$\overline{\text{HOST}}$ = HIGH) SCLK_TCK operates as the JTAG test clock, TCK. NOTE: If the host interface is not being used, tie this pin HIGH.</p>
32	$\overline{\text{BLANK}}$	Synchronous with PCLK	Input	<p>CONTROL SIGNAL INPUT Signal levels are LVCMOS/LVTTL compatible.</p> <p>Used to enable or disable input data blanking.</p> <p>When set LOW, the luma and chroma input data is set to the appropriate blanking levels. Horizontal and vertical ancillary spaces will also be set to blanking levels.</p> <p>When set HIGH, the luma and chroma input data pass through the device unaltered.</p>
33, 68	CORE_GND	–	Power	Ground connection for the digital core logic. Connect to digital GND.
34	F	Synchronous with PCLK	Input	<p>CONTROL SIGNAL INPUT Signal levels are LVCMOS/LVTTL compatible.</p> <p>Used to indicate the ODD / EVEN field of the video signal when DETECT_TRS is set LOW. The device will set the F bit in all outgoing TRS signals for the entire period that the F input signal is HIGH (IOPROC_EN/DIS must also be HIGH).</p> <p>The F signal should be set HIGH for the entire period of field 2 and should be set LOW for all lines in field 1 and for all lines in progressive scan systems.</p> <p>The F signal is ignored when DETECT_TRS = HIGH.</p>

Table 1-1: Pin Descriptions (Continued)

Pin Number	Name	Timing	Type	Description
35	V	Synchronous with PCLK	Input	<p>CONTROL SIGNAL INPUT Signal levels are LVCMOS/LVTTL compatible.</p> <p>Used to indicate the portion of the video field / frame that is used for vertical blanking when DETECT_TRS is set LOW. The device will set the V bit in all outgoing TRS signals for the entire period that the V input signal is HIGH (IOPROC_EN/DIS must also be HIGH).</p> <p>The V signal should be set HIGH for the entire vertical blanking period and should be set LOW for all lines outside of the vertical blanking interval.</p> <p>The V signal is ignored when DETECT_TRS = HIGH.</p>
36	H	Synchronous with PCLK	Input	<p>CONTROL SIGNAL INPUT Signal levels are LVCMOS/LVTTL compatible.</p> <p>Used to indicate the portion of the video line containing active video data when DETECT_TRS is set LOW. The device will set the H bit in all outgoing TRS signals for the entire period that the H input signal is HIGH (IOPROC_EN/DIS must also be HIGH).</p> <p>H signal timing is configurable via the H_CONFIG bit of the IOPROC_DISABLE register, accessible via the host interface.</p> <p>Active Line Blanking (H_CONFIG = 0_h) The H signal should be set HIGH for the entire horizontal blanking period, including the EAV and SAV TRS words, and LOW otherwise. This is the default setting.</p> <p>TRS Based Blanking (H_CONFIG = 1_h) The H signal should be set HIGH for the entire horizontal blanking period as indicated by the H bit in the received TRS ID words, and LOW otherwise.</p>
37, 64	CORE_VDD	–	Power	Power supply connection for the digital core logic. Connect to +1.8V DC digital.

Table 1-1: Pin Descriptions (Continued)

Pin Number	Name	Timing	Type	Description
38, 39, 42-48, 50	DIN[0:9]	Synchronous with PCLK	Input	<p>PARALLEL DATA BUS Signal levels are LVCMOS/LVTTL compatible. DIN9 is the MSB and DIN0 is the LSB.</p> <hr/> <p>HD 20-bit mode SD/HD = LOW 20bit/10bit = HIGH</p> <p>Chroma data input in SMPTE mode SMPTE_BYPASS = HIGH DVB_ASI = LOW</p> <p>Data input in Data-Through mode SMPTE_BYPASS = LOW DVB_ASI = LOW</p> <hr/> <p>HD 10-bit mode SD/HD = LOW 20bit/10bit = LOW</p> <p>High impedance in all modes.</p> <hr/> <p>SD 20-bit mode SD/HD = HIGH 20bit/10bit = HIGH</p> <p>Chroma data input in SMPTE mode SMPTE_BYPASS = HIGH DVB_ASI = LOW</p> <p>Data input in Data-Through mode SMPTE_BYPASS = LOW DVB_ASI = LOW</p> <p>High impedance in DVB-ASI mode SMPTE_BYPASS = LOW DVB_ASI = HIGH</p> <hr/> <p>SD 10-bit mode SD/HD = HIGH 20bit/10bit = LOW</p> <p>High impedance in all modes.</p>
40, 49, 60	IO_GND	–	Power	Ground connection for digital I/O buffers. Connect to digital GND.
41, 53, 61	IO_VDD	–	Power	Power supply connection for digital I/O buffers. Connect to +3.3V DC digital.

Table 1-1: Pin Descriptions (Continued)

Pin Number	Name	Timing	Type	Description		
51, 52, 54-59, 62, 63	DIN[10:19]	Synchronous with PCLK	Input	PARALLEL DATA BUS Signal levels are LVCMOS/LVTTL compatible. DIN19 is the MSB and DIN10 is the LSB.		
				<table border="0"> <tr> <td>HD 20-bit mode SD/HD = LOW 20bit/10bit = HIGH</td> <td> <u>Luma data input in SMPTE mode</u> SMPTE_BYPASS = HIGH DVB_ASI = LOW <u>Data input in Data-Through mode</u> SMPTE_BYPASS = LOW DVB_ASI = LOW </td> </tr> </table>	HD 20-bit mode SD/HD = LOW 20bit/10bit = HIGH	<u>Luma data input in SMPTE mode</u> SMPTE_BYPASS = HIGH DVB_ASI = LOW <u>Data input in Data-Through mode</u> SMPTE_BYPASS = LOW DVB_ASI = LOW
				HD 20-bit mode SD/HD = LOW 20bit/10bit = HIGH	<u>Luma data input in SMPTE mode</u> SMPTE_BYPASS = HIGH DVB_ASI = LOW <u>Data input in Data-Through mode</u> SMPTE_BYPASS = LOW DVB_ASI = LOW	
				<table border="0"> <tr> <td>HD 10-bit mode SD/HD = LOW 20bit/10bit = LOW</td> <td> <u>Multiplexed Luma and Chroma data input in SMPTE mode</u> SMPTE_BYPASS = HIGH DVB_ASI = LOW <u>Data input in Data-Through mode</u> SMPTE_BYPASS = LOW DVB_ASI = LOW </td> </tr> </table>	HD 10-bit mode SD/HD = LOW 20bit/10bit = LOW	<u>Multiplexed Luma and Chroma data input in SMPTE mode</u> SMPTE_BYPASS = HIGH DVB_ASI = LOW <u>Data input in Data-Through mode</u> SMPTE_BYPASS = LOW DVB_ASI = LOW
				HD 10-bit mode SD/HD = LOW 20bit/10bit = LOW	<u>Multiplexed Luma and Chroma data input in SMPTE mode</u> SMPTE_BYPASS = HIGH DVB_ASI = LOW <u>Data input in Data-Through mode</u> SMPTE_BYPASS = LOW DVB_ASI = LOW	
<table border="0"> <tr> <td>SD 20-bit mode SD/HD = HIGH 20bit/10bit = HIGH</td> <td> <u>Luma data input in SMPTE mode</u> SMPTE_BYPASS = HIGH DVB_ASI = LOW <u>Data input in Data-Through mode</u> SMPTE_BYPASS = LOW DVB_ASI = LOW <u>DVB-ASI data input in DVB-ASI mode</u> SMPTE_BYPASS = LOW DVB_ASI = HIGH </td> </tr> </table>	SD 20-bit mode SD/HD = HIGH 20bit/10bit = HIGH	<u>Luma data input in SMPTE mode</u> SMPTE_BYPASS = HIGH DVB_ASI = LOW <u>Data input in Data-Through mode</u> SMPTE_BYPASS = LOW DVB_ASI = LOW <u>DVB-ASI data input in DVB-ASI mode</u> SMPTE_BYPASS = LOW DVB_ASI = HIGH				
SD 20-bit mode SD/HD = HIGH 20bit/10bit = HIGH	<u>Luma data input in SMPTE mode</u> SMPTE_BYPASS = HIGH DVB_ASI = LOW <u>Data input in Data-Through mode</u> SMPTE_BYPASS = LOW DVB_ASI = LOW <u>DVB-ASI data input in DVB-ASI mode</u> SMPTE_BYPASS = LOW DVB_ASI = HIGH					
<table border="0"> <tr> <td>SD 10-bit mode SD/HD = HIGH 20bit/10bit = LOW</td> <td> <u>Multiplexed Luma and Chroma data input in SMPTE mode</u> SMPTE_BYPASS = HIGH DVB_ASI = LOW <u>Data input in data through mode</u> SMPTE_BYPASS = LOW DVB_ASI = LOW <u>DVB-ASI data input in DVB-ASI mode</u> SMPTE_BYPASS = LOW DVB_ASI = HIGH </td> </tr> </table>	SD 10-bit mode SD/HD = HIGH 20bit/10bit = LOW	<u>Multiplexed Luma and Chroma data input in SMPTE mode</u> SMPTE_BYPASS = HIGH DVB_ASI = LOW <u>Data input in data through mode</u> SMPTE_BYPASS = LOW DVB_ASI = LOW <u>DVB-ASI data input in DVB-ASI mode</u> SMPTE_BYPASS = LOW DVB_ASI = HIGH				
SD 10-bit mode SD/HD = HIGH 20bit/10bit = LOW	<u>Multiplexed Luma and Chroma data input in SMPTE mode</u> SMPTE_BYPASS = HIGH DVB_ASI = LOW <u>Data input in data through mode</u> SMPTE_BYPASS = LOW DVB_ASI = LOW <u>DVB-ASI data input in DVB-ASI mode</u> SMPTE_BYPASS = LOW DVB_ASI = HIGH					
67	DETECT_TRS	Non Synchronous	Input	CONTROL SIGNAL INPUT Signal levels are LVCMOS/LVTTL compatible. Used to select the timing mode of the device. When set HIGH, the device will lock the internal flywheel to the embedded TRS timing signals in the parallel input data. When set LOW, the device will lock the internal flywheel to the externally supplied H, V, and F input signals.		

Table 1-1: Pin Descriptions (Continued)

Pin Number	Name	Timing	Type	Description	
69	PCLK	–	Input	PARALLEL DATA BUS CLOCK Signal levels are LVCMOS/LVTTL compatible.	
				HD 20-bit mode	PCLK = 74.25MHz or 74.25/1.001MHz
				HD 10-bit mode	PCLK = 148.5MHz or 148.5/1.001MHz
				SD 20-bit mode	PCLK = 13.5MHz
				SD 10-bit mode	PCLK = 27MHz
72	LOCKED	Synchronous with PCLK	Output	STATUS SIGNAL OUTPUT Signal levels are LVCMOS / LVTTL compatible. The LOCKED signal will be HIGH whenever the device has correctly received and locked to SMPTE compliant data in SMPTE mode or DVB-ASI compliant data in DVB-ASI mode, or when the device has achieved lock in Data-Through mode. It will be LOW otherwise.	
73, 74	VCO, $\overline{\text{VCO}}$	Analog	Input	Differential inputs for the external VCO reference signal. For single ended devices such as the GO1555/GO1525*, VCO should be AC coupled to VCO_GND. VCO is nominally 1.485GHz. *For new designs use GO1555	
75	VCO_GND	–	Output Power	Ground reference for the external voltage controlled oscillator. Connect to pins 2, 4, 6, and 8 of the GO1555/GO1525*. This pin is an output. Should be isolated from all other grounds. *For new designs use GO1555	
76	VCO_VCC	–	Output Power	Power supply for the external voltage controlled oscillator. Connect to pin 7 of the GO1555/GO1525*. This pin is an output. Should be isolated from all other power supplies. *For new designs use GO1555	
77	LF	Analog	Output	Control voltage to external voltage controlled oscillator. Nominally +1.25V DC.	
78	CP_CAP	Analog	Input	PLL lock time constant capacitor connection. Normally connected to VCO_GND through 2.2nF.	
79	LB_CONT	Analog	Input	Control voltage to set the loop bandwidth of the integrated reclocker. Normally connected to VCO_VDD through 15k Ω .	
80	CP_GND	–	Power	Ground connection for the charge pump. Connect to analog GND.	

2. Electrical Characteristics

2.1 Absolute Maximum Ratings

Parameter	Value/Units
Supply Voltage Core	-0.3V to +2.1V
Supply Voltage I/O	-0.3V to +4.6V
Input Voltage Range (any input)	-2.0V to + 5.25V
Ambient Operating Temperature	$-20^{\circ}\text{C} \leq T_A \leq 85^{\circ}\text{C}$
Storage Temperature	$-40^{\circ}\text{C} \leq T_{\text{STG}} \leq 125^{\circ}\text{C}$
Lead Temperature (soldering, 10 sec)	230°C
ESD Protection On All Pins	1kV

NOTES:

1. See reflow solder profiles ([Solder Reflow Profiles on page 18](#))
2. MIL STD 883 ESD protection applied to all pins on the device.

2.2 DC Electrical Characteristics

Table 2-1: DC Electrical Characteristics

$T_A = 0^{\circ}\text{C}$ to 70°C , unless otherwise specified.

Parameter	Symbol	Conditions	Min	Typ	Max	Units	Test Levels	Notes
System								
Operation Temperature Range	T_A	–	0	–	70	°C	–	1
Digital Core Supply Voltage	CORE_VDD	–	1.65	1.8	1.95	V	1	1
Digital I/O Supply Voltage	IO_VDD	–	3.0	3.3	3.6	V	1	1
Charge Pump Supply Voltage	CP_VDD	–	3.0	3.3	3.6	V	1	1
Phase Detector Supply Voltage	PD_VDD	–	1.65	1.8	1.95	V	1	1
Input Buffer Supply Voltage	BUFF_VDD	–	1.65	1.8	1.95	V	1	1
Cable Driver Supply Voltage	CD_VDD	–	1.71	1.8	1.89	V	1	1
External VCO Supply Voltage Output	VCO_VCC	–	2.25	2.50	2.75	V	1	–
+1.8V Supply Current	I_{1V8}	–	–	–	245	mA	1	4
+3.3V Supply Current	I_{3V3}	–	–	–	45	mA	1	–

Table 2-1: DC Electrical Characteristics (Continued)T_A = 0°C to 70°C, unless otherwise specified.

Parameter	Symbol	Conditions	Min	Typ	Max	Units	Test Levels	Notes
Total Device Power	P _D	–	–	–	590	mW	5	4
ESD Protection on all Pins	–	–	1	–	–	kV	–	2
Digital I/O								
Input Logic LOW	V _{IL}	–	–	–	0.8	V	1	–
Input Logic HIGH	V _{IH}	–	2.1	–	–	V	1	–
Output Logic LOW	V _{OL}	8mA	–	0.2	0.4	V	1	–
Output Logic HIGH	V _{OH}	8mA	IO_VDD - 0.4	–	–	V	1	–
Input								
RSET Voltage	V _{RSET}	RSET=281Ω	0.54	0.6	0.66	V	1	3
Output								
Output Common Mode Voltage	V _{CMOUT}	75Ω load, RSET=281Ω, SD and HD	0.8	1.0	1.2	V	1	–

TEST LEVELS

1. Production test at room temperature and nominal supply voltage with guardbands for supply and temperature ranges.
2. Production test at room temperature and nominal supply voltage with guardbands for supply and temperature ranges using correlated test.
3. Production test at room temperature and nominal supply voltage.
4. QA sample test.
5. Calculated result based on Level 1, 2, or 3.
6. Not tested. Guaranteed by design simulations.
7. Not tested. Based on characterization of nominal parts.
8. Not tested. Based on existing design/characterization data of similar product.
9. Indirect test.

NOTES

1. All DC and AC electrical parameters within specification.
2. MIL STD 883 ESD protection will be applied to all pins on the device.
3. Set by the value of the RSET resistor.
4. SDO outputs enabled.

2.3 AC Electrical Characteristics

Table 2-2: AC Electrical Characteristics

$T_A = 0^\circ\text{C}$ to 70°C , unless otherwise shown

Parameter	Symbol	Conditions	Min	Typ	Max	Units	Test Levels	Notes
System								
Device Latency	–	10-bit SD	–	21	–	PCLK	6	–
		20-bit HD	–	19	–	PCLK	6	–
		DVB-ASI	–	11	–	PCLK	6	–
Reset Pulse Width	t_{reset}	–	1	–	–	ms	7	3
Parallel Input								
Parallel Clock Frequency	f_{PCLK}	–	13.5	–	148.5	MHz	1	–
Parallel Clock Duty Cycle	DC_{PCLK}	–	40	50	60	%	1	–
Input Data Setup Time	t_{SU}	–	2	–	–	ns	1	1
Input Data Hold Time	t_{IH}	–	1.5	–	–	ns	1	1
Serial Digital Output								
Serial Output Data Rate	DR_{SDO}	–	–	1.485, 1.485/1.001, 270	–	Gb/s Gb/s Mb/s	1	–
Serial Output Swing	ΔV_{SDD}	RSET = 281 Ω Load = 75 Ω	–	800	–	mVp-p	1	–
Serial Output Rise Time 20% ~ 80%	t_{rSDO}	ORL compensation using recommended circuit — HD signal	–	200	260	ps	1	–
	t_{rSDO}	ORL compensation using recommended circuit — SD signal	400	550	1500	ps	1	–
Serial Output Fall Time 20% ~ 80%	t_{fSDO}	ORL compensation using recommended circuit — HD signal	–	235	260	ps	1	–
	t_{fSDO}	ORL compensation using recommended circuit — SD signal	400	550	1500	ps	1	–
Serial Output Intrinsic Jitter	t_{IJ}	Pseudorandom and pathological HD signal	–	90	125	ps	1	–
	t_{IJ}	Pseudorandom and pathological SD signal	–	270	350	ps	1	–
Serial Output Duty Cycle Distortion	DCD_{SDO}	HD (1.485Gb/s)	–	10	–	ps	1	2
	DCD_{SDO}	SD (270Mb/s)	–	20	–	ps	1	2

Table 2-2: AC Electrical Characteristics (Continued)

T_A = 0°C to 70°C, unless otherwise shown

Parameter	Symbol	Conditions	Min	Typ	Max	Units	Test Levels	Notes
GSPI								
GSPI Input Clock Frequency	f _{SCLK}	–	–	–	6.6	MHz	1	–
GSPI Input Clock Duty Cycle	DC _{SCLK}	–	40	50	60	%	6,7	–
GSPI Input Data Setup Time	–	–	0	–	–	ns	6,7	–
GSPI Input Data Hold Time	–	–	–	–	1.43	ns	6,7	–
GSPI Output Data Hold Time	–	–	2.10	–	–	ns	6,7	–
GSPI Output Data Delay Time	–	–	–	–	7.27	ns	6,7	–

TEST LEVELS

1. Production test at room temperature and nominal supply voltage with guardbands for supply and temperature ranges.
2. Production test at room temperature and nominal supply voltage with guardbands for supply and temperature ranges using correlated test.
3. Production test at room temperature and nominal supply voltage.
4. QA sample test.
5. Calculated result based on Level 1, 2, or 3.
6. Not tested. Guaranteed by design simulations.
7. Not tested. Based on characterization of nominal parts.
8. Not tested. Based on existing design/characterization data of similar product.
9. Indirect test.

NOTES

1. With 15pF load.
2. Serial Duty Cycle Distortion is defined here to be the difference between the width of a '1' bit, and the width of a '0' bit.
3. See [Device Power Up on page 46, Figure 3-13](#).

2.4 Solder Reflow Profiles

The device is manufactured with Matte-Sn terminations and is compatible with both standard eutectic and Pb-free solder reflow profiles. The recommended standard eutectic reflow profile is shown in [Figure 2-1](#). MSL qualification was performed using the maximum Pb-free reflow profile shown in [Figure 2-2](#).

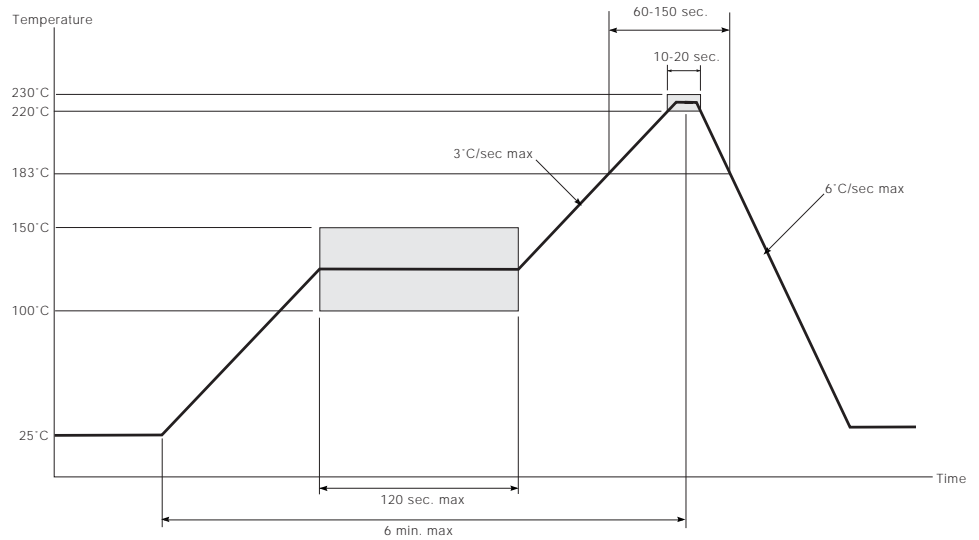

Figure 2-1: Standard Eutectic Solder Reflow Profile

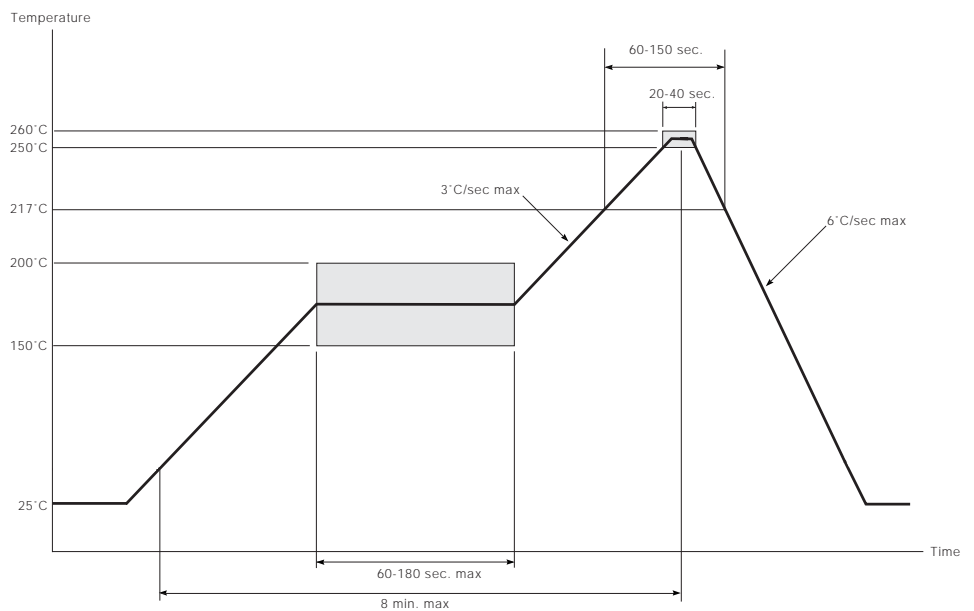

Figure 2-2: Maximum Pb-free Solder Reflow Profile (Preferred)

2.5 Input/Output Circuits

All resistors in ohms, all capacitors in farads, unless otherwise shown.

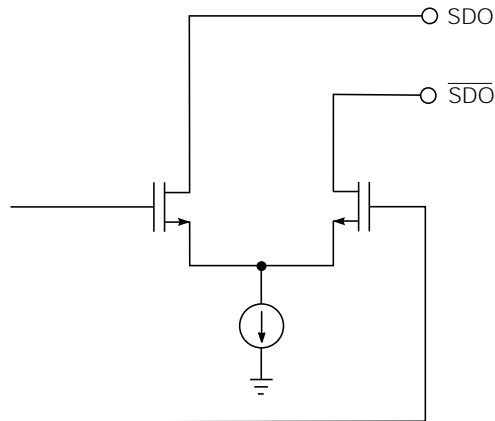

Figure 2-3: Serial Digital Output

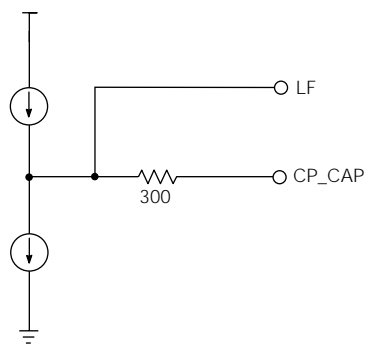

Figure 2-4: VCO Control Output & PLL Lock Time Capacitor

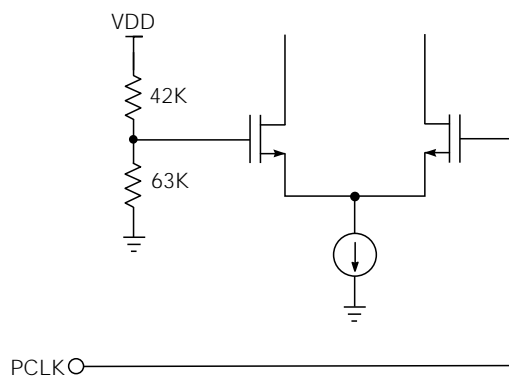

Figure 2-5: PCLK Input

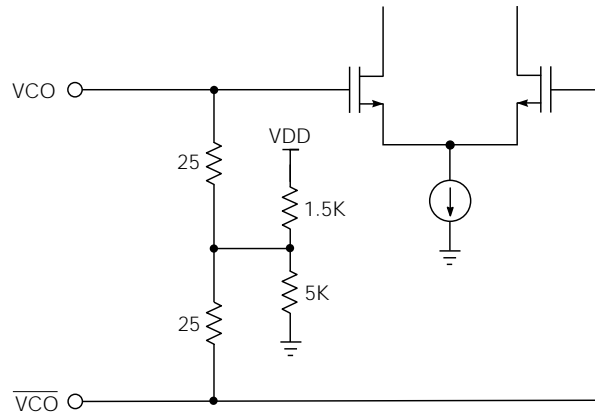

Figure 2-6: VCO Input

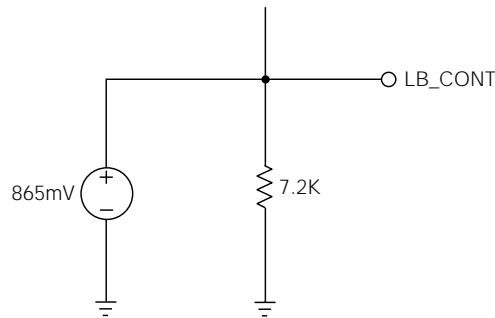

Figure 2-7: PLL Loop Bandwidth Control

2.6 Host Interface Maps

REGISTER NAME	15	14	13	12	11	10	9	8	7	6	5	4	3	2	1	0
LINE_352M_I2	Not Used	Not Used	Not Used	Not Used	Not Used	b10	b9	b8	b7	b6	b5	b4	b3	b2	b1	b0
LINE_352M_I1	Not Used	Not Used	Not Used	Not Used	Not Used	b10	b9	b8	b7	b6	b5	b4	b3	b2	b1	b0
1Ah																
FE_LINE_END_F1	Not Used	Not Used	Not Used	Not Used	Not Used	Not Used	b9	b8	b7	b6	b5	b4	b3	b2	b1	b0
FE_LINE_START_F1	Not Used	Not Used	Not Used	Not Used	Not Used	Not Used	b9	b8	b7	b6	b5	b4	b3	b2	b1	b0
FE_LINE_END_F0	Not Used	Not Used	Not Used	Not Used	Not Used	Not Used	b9	b8	b7	b6	b5	b4	b3	b2	b1	b0
FE_LINE_START_F0	Not Used	Not Used	Not Used	Not Used	Not Used	Not Used	b9	b8	b7	b6	b5	b4	b3	b2	b1	b0
AP_LINE_END_F1	Not Used	Not Used	Not Used	Not Used	Not Used	Not Used	b9	b8	b7	b6	b5	b4	b3	b2	b1	b0
AP_LINE_START_F1	Not Used	Not Used	Not Used	Not Used	Not Used	Not Used	b9	b8	b7	b6	b5	b4	b3	b2	b1	b0
AP_LINE_END_F0	Not Used	Not Used	Not Used	Not Used	Not Used	Not Used	b9	b8	b7	b6	b5	b4	b3	b2	b1	b0
AP_LINE_START_F0	Not Used	Not Used	Not Used	Not Used	Not Used	Not Used	b9	b8	b7	b6	b5	b4	b3	b2	b1	b0
RASTER_STRUCTURE4	Not Used	Not Used	Not Used	Not Used	Not Used	b10	b9	b8	b7	b6	b5	b4	b3	b2	b1	b0
RASTER_STRUCTURE3	Not Used	Not Used	Not Used	Not Used	Not Used	b10	b9	b8	b7	b6	b5	b4	b3	b2	b1	b0
RASTER_STRUCTURE2	Not Used	Not Used	Not Used	Not Used	Not Used	b11	b9	b8	b7	b6	b5	b4	b3	b2	b1	b0
RASTER_STRUCTURE1	Not Used	Not Used	Not Used	Not Used	Not Used	b11	b9	b8	b7	b6	b5	b4	b3	b2	b1	b0
0Dh																
0Ch																
VIDEO_FORMAT_B	VF4-b7	VF4-b6	VF4-b5	VF4-b4	VF4-b3	VF4-b2	VF4-b1	VF4-b0	VF3-b7	VF3-b6	VF3-b5	VF3-b4	VF3-b3	VF3-b2	VF3-b1	VF3-b0
VIDEO_FORMAT_A	VF2-b7	VF2-b6	VF2-b5	VF2-b4	VF2-b3	VF2-b2	VF2-b1	VF2-b0	VF1-b7	VF1-b6	VF1-b5	VF1-b4	VF1-b3	VF1-b2	VF1-b1	VF1-b0
08h																
07h																
06h																
05h																
VIDEO_STANDARD	Not Used	VDS-b4	VDS-b3	VDS-b2	VDS-b1	VDS-b0	INT_PROG	STD_LOCK	NOT USED	NOT USED	NOT USED	NOT USED	NOT USED	NOT USED	NOT USED	NOT USED
EDH_FLAG	Not Used	ANC-UES	ANC-IDA	ANC-IDH	ANC-EDA	ANC-EDH	FF-UES	FF-IDA	FF-IDH	FF-EDA	FF-EDH	AP-UES	AP-IDA	AP-IDH	AP-EDA	AP-EDH
01h																
IOPROC_DISABLE	Not Used	Not Used	Not Used	Not Used	Not Used	Not Used	Not Used	H_CONFIG	Not Used	352M_INS	ILLEGAL_REMAP	EDH_CRC_INS	ANC_CSUM_INS	CRC_INS	LNUM_INS	TRS_INS

2.6.1 Host Interface Map (Read Only Registers)

REGISTER NAME	ADDRESS	15	14	13	12	11	10	9	8	7	6	5	4	3	2	1	0
	1Ch																
	1Bh																
	1Ah																
	19h																
	18h																
	17h																
	16h																
	15h																
	14h																
	13h																
	12h																
RASTER_STRUCTURE4	11h						b10	b9	b8	b7	b6	b5	b4	b3	b2	b1	b0
RASTER_STRUCTURE3	10h						b10	b9	b8	b7	b6	b5	b4	b3	b2	b1	b0
RASTER_STRUCTURE2	0Fh					b11	b10	b9	b8	b7	b6	b5	b4	b3	b2	b1	b0
RASTER_STRUCTURE1	0Eh					b11	b10	b9	b8	b7	b6	b5	b4	b3	b2	b1	b0
	0Dh																
	0Ch																
	0Bh																
	0Ah																
	09h																
	08h																
	07h																
	06h																
	05h																
VIDEO_STANDARD	04h		VDS-b4	VDS-h3	VDS-b2	VDS-b1	VDS-b0	INT_PROG	STD_LOCK								
	03h																
	02h																
	01h																
	00h																

2.6.2 Host Interface Map (R/W Configurable Registers)

REGISTER NAME	ADDRESS	15	14	13	12	11	10	9	8	7	6	5	4	3	2	1	0
LINE_352M_I2	1Ch						b10	b9	b8	b7	b6	b5	b4	b3	b2	b1	b0
LINE_352M_J1	1Bh						b10	b9	b8	b7	b6	b5	b4	b3	b2	b1	b0
FF_LINE_END_F1	1Ah																
FF_LINE_START_F1	19h							b9	b8	b7	b6	b5	b4	b3	b2	b1	b0
FF_LINE_END_F0	17h							b9	b8	b7	b6	b5	b4	b3	b2	b1	b0
FF_LINE_START_F0	16h							b9	b8	b7	b6	b5	b4	b3	b2	b1	b0
AP_LINE_END_F1	15h							b9	b8	b7	b6	b5	b4	b3	b2	b1	b0
AP_LINE_START_F1	14h							b9	b8	b7	b6	b5	b4	b3	b2	b1	b0
AP_LINE_END_F0	13h							b9	b8	b7	b6	b5	b4	b3	b2	b1	b0
AP_LINE_START_F0	12h							b9	b8	b7	b6	b5	b4	b3	b2	b1	b0
	11h																
	10h																
	0Fh																
	0Eh																
	0Dh																
	0Ch																
VIDEO_FORMAT_B	0Bh	VF4-b7	VF4-b6	VF4-b5	VF4-b4	VF4-b3	VF4-b2	VF4-b1	VF4-b0	VF3-b7	VF3-b6	VF3-b5	VF3-b4	VF3-b3	VF3-b2	VF3-b1	VF3-b0
VIDEO_FORMAT_A	0Ah	VF2-b7	VF2-b6	VF2-b5	VF2-b4	VF2-b3	VF2-b2	VF2-b1	VF2-b0	VF1-b7	VF1-b6	VF1-b5	VF1-b4	VF1-b3	VF1-b2	VF1-b1	VF1-b0
	08h																
	07h																
	06h																
	05h																
	04h																
	03h																
EDH_FLAG	02h	ANC-UJES	ANC-IDA	ANC-IDH	ANC-EDA	ANC-EDH	FF-UJES	FF-IDA	FF-IDH	FF-EDA	FF-EDH	AP-UJES	AP-IDA	AP-IDH	AP-EDA	AP-EDH	
	01h																
IOPROC_DISABLE	00h								H_CONFIG		352M_INS	ILLEGAL_REMAP	EDH_CRC_INS	ANC_CSUM_INS	CRC_INS	UNUM_INS	TRS_INS

3. Detailed Description

3.1 Functional Overview

The GS1532 is a multi-rate serializer with an integrated cable driver. When used in conjunction with the external GO1555/GO1525* Voltage Controlled Oscillator, a transmit solution at 1.485Gb/s, 1.485/1.001Gb/s or 270Mb/s is realized.

The device has three different modes of operation which must be set by the application layer through external device pins.

When SMPTE mode is enabled, the device will accept 10-bit multiplexed or 20-bit demultiplexed SMPTE compliant data at both HD and SD signal rates. The device's additional processing features are also enabled in this mode.

In DVB-ASI mode, the GS1532 will accept an 8-bit parallel DVB-ASI compliant transport stream on its upper input bus. The serial output data stream will be 8b/10b encoded and stuffed.

The GS1532's third mode allows for the serializing of data not conforming to SMPTE or DVB-ASI streams.

The provided serial digital outputs feature a high impedance mode, output mute on loss of parallel clock and adjustable signal swing. The output slew rate is automatically controlled by the SD/HD setting.

In the digital signal processing core, several data processing functions are implemented including SMPTE 352M and EDH data packet generation and insertion, and automatic video standards detection. These features are all enabled by default, but may be individually disabled via internal registers accessible through the GSPI host interface.

Finally, the GS1532 contains a JTAG interface for boundary scan test implementations.

*For new designs use GO1555

3.2 Parallel Data Inputs

Data inputs enter the device on the rising edge of PCLK as shown in [Figure 3-1](#).

The input data format is defined by the setting of the external $\overline{\text{SD/HD}}$, $\overline{\text{SMPTE_BYPASS}}$ and $\overline{\text{DVB_ASI}}$ pins and may be presented in 10-bit or 20-bit format. The input data bus width is controlled independently from the internal data bus width by the 20bit/10bit input pin.

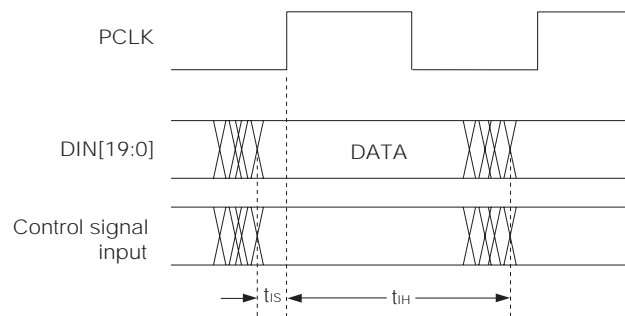

Figure 3-1: PCLK to Data Timing

3.2.1 Parallel Input in SMPTE Mode

When the device is operating in SMPTE mode, (see [SMPTE Mode on page 27](#)), both SD and HD data may be presented to the input bus in either multiplexed or demultiplexed form depending on the setting of the 20bit/10bit input pin.

In 20-bit mode, (20bit/10bit = HIGH), the input data format should be word aligned, demultiplexed luma and chroma data. Luma words should be presented to DIN[19:10] while chroma words should occupy DIN[9:0].

In 10-bit mode, (20bit/10bit = LOW), the input data format should be word aligned, multiplexed luma and chroma data. The data should be presented to DIN[19:10]. DIN[9:0] will be high impedance in this mode.

3.2.2 Parallel Input in DVB-ASI Mode

When operating in DVB-ASI mode, (see [DVB-ASI mode on page 29](#)), the GS1532 automatically configures the input port for 10-bit operation regardless of the setting of the 20bit/10bit pin.

The device will accept 8-bit data words on DIN[17:10] such that DIN17 = HIN is the most significant bit of the encoded transport stream data and DIN10 = AIN is the least significant bit.

In addition, DIN19 and DIN18 will be configured as the DVB-ASI control signals INSSYNCIN and KIN respectively. See [DVB-ASI mode on page 29](#) for a description of these DVB-ASI specific input signals.

DIN[9:0] will be high impedance when the GS1532 is operating in DVB-ASI mode.

3.2.3 Parallel Input in Data-Through Mode

When operating in Data-Through mode, (see [Data-Through Mode on page 29](#)), the GS1532 passes data presented to the parallel input bus to the serial output without performing any encoding or scrambling.

The input data bus width accepted by the device in this mode is controlled by the setting of the 20bit/10bit pin.

3.2.4 Parallel Input Clock (PCLK)

The frequency of the PCLK input signal required by the GS1532 is determined by the input data format. Table 3-1 below lists the possible input signal formats and their corresponding parallel clock rates. Note that DVB-ASI input will always be in 10-bit format, regardless of the setting of the 20bit/10bit pin.

Table 3-1: Parallel Data Input Format

Input Data Format	DIN [19:10]	DIN [9:0]	PCLK	Control Signals			
				20bit/ 10bit	SD/ HD	SMPTE_BYPASS	DVB_ASI
SMPTE MODE							
20bit DEMULTIPLEXED SD	LUMA	CHROMA	13.5MHz	HIGH	HIGH	HIGH	LOW
10bit MULTIPLEXED SD	LUMA / CHROMA	HIGH IMPEDANCE	27MHz	LOW	HIGH	HIGH	LOW
20bit DEMULTIPLEXED HD	LUMA	CHROMA	74.25 or 74.25/ 1.001MHz	HIGH	LOW	HIGH	LOW
10bit MULTIPLEXED HD	LUMA / CHROMA	HIGH IMPEDANCE	148.5 or 148.5/ 1.001MHz	LOW	LOW	HIGH	LOW
DVB-ASI MODE							
10bit DVB-ASI	DVB-ASI DATA	HIGH IMPEDANCE	27MHz	HIGH	HIGH	LOW	HIGH
				LOW	HIGH	LOW	HIGH
DATA-THROUGH MODE							
20bit DEMULTIPLEXED SD	DATA	DATA	13.5MHz	HIGH	HIGH	LOW	LOW
10bit MULTIPLEXED SD	DATA	HIGH IMPEDANCE	27MHz	LOW	HIGH	LOW	LOW
20bit DEMULTIPLEXED HD	DATA	DATA	74.25 or 74.25/ 1.001MHz	HIGH	LOW	LOW	LOW
10bit MULTIPLEXED HD	DATA	HIGH IMPEDANCE	148.5 or 148.5/ 1.001MHz	LOW	LOW	LOW	LOW

3.3 SMPTE Mode

The GS1532 is said to be in SMPTE mode when the $\overline{\text{SMPTE_BYPASS}}$ pin is set HIGH and the DVB_ASI pin is set LOW.

In this mode, the parallel data will be scrambled according to SMPTE 259M or 292M, and NRZ-to-NRZI encoded prior to serialization.

3.3.1 Internal Flywheel

The GS1532 has an internal flywheel which is used in the generation of internal / external timing signals, and in automatic video standards detection. It is operational in SMPTE mode only.

The flywheel consists of a number of counters and comparators operating at video pixel and video line rates. These counters maintain information about the total line length, active line length, total number of lines per field / frame and total active lines per field / frame for the received video standard.

When DETECT_TRS is LOW, the flywheel will be locked to the externally supplied H, V, and F timing signals.

When DETECT_TRS is HIGH, the flywheel will be locked to the embedded TRS signals in the parallel input data. Both 8-bit and 10-bit TRS code words will be identified by the device.

The flywheel 'learns' the video standard by timing the horizontal and vertical reference information supplied at the H, V, and F input pins, or contained in the TRS ID words of the received video data. Full synchronization of the flywheel to the received video standard therefore requires one complete video frame.

Once synchronization has been achieved, the flywheel will continue to monitor the received TRS timing or the supplied H, V, and F timing information to maintain synchronization.

3.3.2 HVF Timing Signal Extraction

As discussed above, the GS1532's internal flywheel may be locked to externally provided H, V, and F signals when DETECT_TRS is set LOW by the application layer.

The H signal timing should also be configured via the H_CONFIG bit of the internal IOPROC_DISABLE register as either active line based blanking or TRS based blanking, (see [Packet Generation and Insertion on page 32](#)).

Active line based blanking is enabled when the H_CONFIG bit is set LOW. In this mode, the H input should be HIGH for the entire horizontal blanking period, including the EAV and SAV TRS words. This is the default H timing assumed by the device.

When H_CONFIG is set HIGH, TRS based blanking is enabled. In this case, the H input should be set HIGH for the entire horizontal blanking period as indicated by the H bit in the associated TRS words.

The timing of these signals is shown in Figure 3-2.

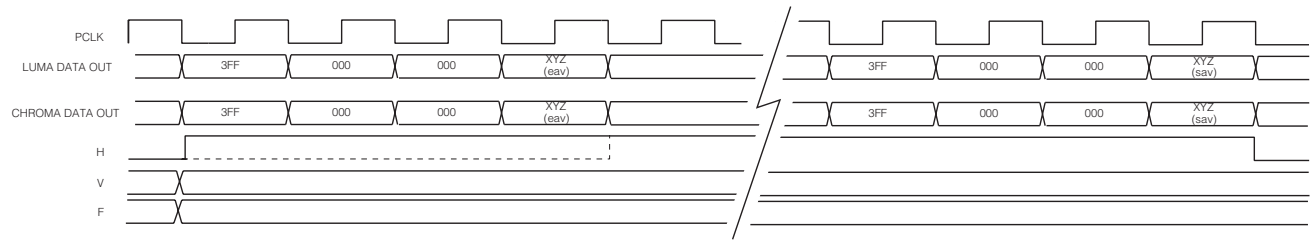

H:V:F TIMING - HD 20-BIT INPUT MODE

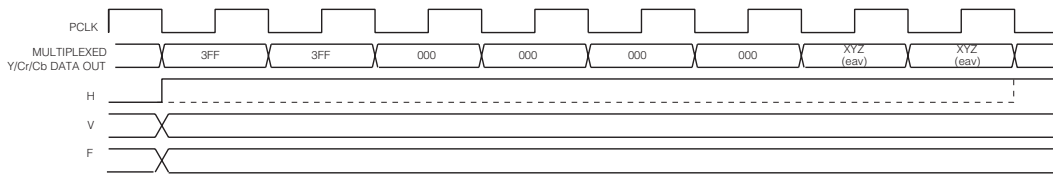

H:V:F TIMING AT EAV - HD 10-BIT INPUT MODE

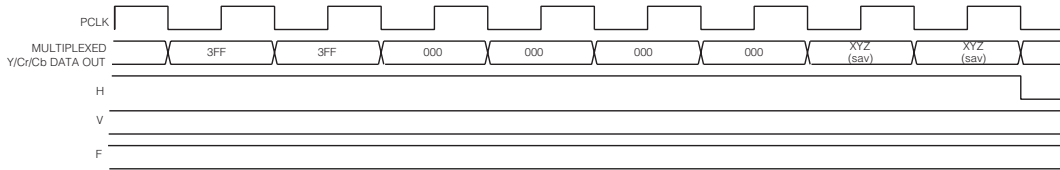

H:V:F TIMING AT SAV - HD 10-BIT INPUT MODE

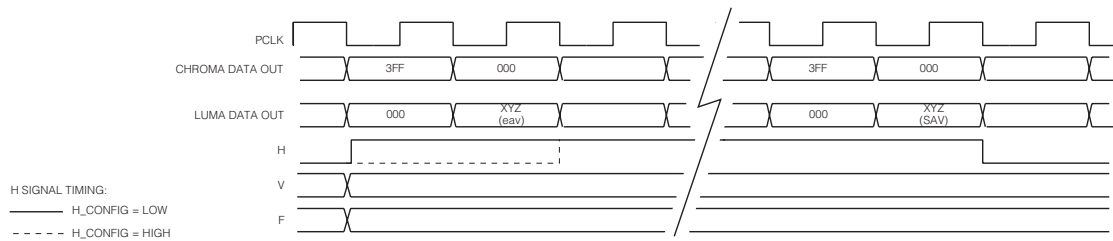

H:V:F TIMING - SD 20-BIT INPUT MODE

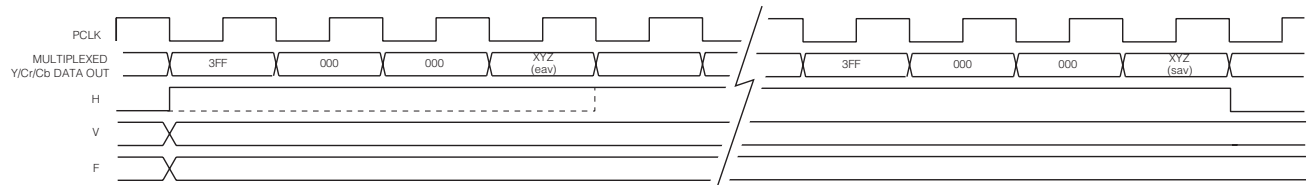

H:V:F TIMING - SD 10-BIT INPUT MODE

Figure 3-2: H, V, F Timing

3.4 DVB-ASI mode

The GS1532 is said to be in DVB-ASI mode when the $\overline{\text{SMPTE_BYPASS}}$ pin is set LOW and the DVB_ASI and SD/HD pins are set HIGH.

In this mode, all SMPTE processing functions are disabled, and the 8-bit transport stream data will be 8b/10b encoded prior to serialization.

3.4.1 Control Signal Inputs

In DVB-ASI mode, the DIN19 and DIN18 pins will be configured as DVB-ASI control signals INSSYNCIN and KIN respectively.

When INSSYNCIN is set HIGH, the device will insert K28.5 sync characters into the data stream. This function is used to assist system implementations where the GS1532 may be preceded by an external data FIFO. Parallel DVB-ASI data may be clocked into the FIFO at some rate less than 27MHz. The INSSYNCIN input may then be connected to the FIFO empty signal, thus providing a means of padding up the data transmission rate to 27MHz. See [Figure 3-3](#).

NOTE: 8b/10b encoding will take place after K28.5 sync character insertion.

KIN should be set HIGH whenever the parallel data input is to be interpreted as any special character defined by the DVB-ASI standard (including the K28.5 sync character). This pin should be set LOW when the input is to be interpreted as data.

NOTE: When operating in DVB-ASI mode, DIN[9:0] become high impedance.

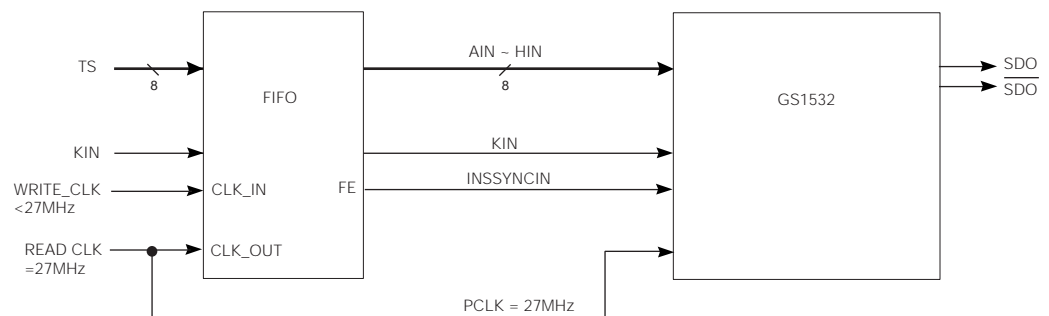

Figure 3-3: DVB-ASI FIFO Implementation using the GS1532

3.5 Data-Through Mode

The GS1532 may be configured by the application layer to operate as a simple parallel-to-serial converter. In this mode, the device presents data to the output buffer without performing any scrambling or encoding.

Data-through mode is enabled only when both the $\overline{\text{SMPTE_BYPASS}}$ and DVB_ASI pins are set LOW.

3.6 Additional Processing Functions

The GS1532 contains an additional data processing block which is available in SMPTE mode only, (see [SMPTE Mode on page 27](#)).

3.6.1 Input Data Blank

The video input data may be 'blanked' by the GS1532. In this mode, all input video data except TRS words are set to the appropriate blanking levels by the device. Both the horizontal and vertical ancillary data spaces will also be set to blanking levels.

This function is enabled by setting the $\overline{\text{BLANK}}$ pin LOW.

3.6.2 Automatic Video Standard Detection

The GS1532 can detect the input video standard by using the timing parameters extracted from the received TRS ID words or supplied H, V, and F timing signals (see [Internal Flywheel on page 27](#)). This information is presented to the host interface via the VIDEO_STANDARD register ([Table 3-2](#)).

Total samples per line, active samples per line, total lines per field/frame and active lines per field/frame are also calculated and presented to the host interface via the RASTER_STRUCTURE registers ([Table 3-3](#)). These line and sample count registers are updated once per frame at the end of line 12. This is in addition to the information contained in the VIDEO_STANDARD register.

After device reset, the four RASTER_STRUCTURE registers default to zero.

Table 3-2: Host Interface Description for Video Standard Register

Register Name	Bit	Name	Description	R/W	Default
VIDEO_STANDARD Address: 004h	15	–	Not Used.	–	–
	14-10	VD_STD[4:0]	Video Data Standard (see Table 3-4).	R	0
	9	INT_ $\overline{\text{PROG}}$	Interlace/Progressive: Set LOW if detected video standard is PROGRESSIVE and is set HIGH if it is INTERLACED.	R	0
	8	STD_LOCK	Standard Lock: Set HIGH when flywheel has achieved full synchronization.	R	0
	7-0	–	Not Used.	–	–

Table 3-3: Host Interface Description for Raster Structure Registers

Register Name	Bit	Name	Description	R/W	Default
RASTER_STRUCTURE1 Address: 00Eh	15-12	–	Not Used.	–	–
	11-0	RASTER_STRUCTURE_1[11:0]	Words Per Active Line	R	0
RASTER_STRUCTURE2 Address: 00Fh	15-12	–	Not Used.	–	–
	11-0	RASTER_STRUCTURE_2[11:0]	Words Per Total Line.	R	0
RASTER_STRUCTURE3 Address: 010h	15-11	–	Not Used.	–	–
	10-0	RASTER_STRUCTURE_3[10:0]	Total Lines Per Frame	R	0
RASTER_STRUCTURE4 Address: 011h	15-11	–	Not Used.	–	–
	10-0	RASTER_STRUCTURE_4[10:0]	Active Lines Per Field	R	0

3.6.2.1 Video Standard Indication

The video standard codes reported in the VD_STD[4:0] bits of the VIDEO_STANDARD register represent the SMPTE standards as shown in [Table 3-4](#).

In addition to the 5-bit video standard code word, the VIDEO_STANDARD register also contains two status bits. The STD_LOCK bit will be set HIGH whenever the flywheel has achieved full synchronization. The INT_PROG bit will be set LOW if the detected video standard is progressive and HIGH if the detected video standard is interlaced.

The VD_STD[4:0], STD_LOCK and INT_PROG bits of the VIDEO_STANDARD register will default to zero after device reset. The VD_STD[4:0] and INT_PROG bits will also default to zero if the SMPTE_BYPASS pin is asserted LOW or if the LOCKED output is LOW. The STD_LOCK bit will retain its previous value if the PCLK is removed.

Table 3-4: Supported Video Standards

VD_STD[4:0]	SMPTE Standard	Video Format	Length of HANC	Length of Active Video	Total Samples	SMPTE352M Lines
00h	296M (HD)	1280x720/60 (1:1)	358	1280	1650	13
01h	296M (HD)	1280x720/60 (1:1) - EM	198	1440	1650	13
02h	296M (HD)	1280x720/30 (1:1)	2008	1280	3300	13
03h	296M (HD)	1280x720/30 (1:1) - EM	408	2880	3300	13
04h	296M (HD)	1280x720/50 (1:1)	688	1280	1980	13
05h	296M (HD)	1280x720/50 (1:1) - EM	240	1728	1980	13
06h	296M (HD)	1280x720/25 (1:1)	2668	1280	3960	13
07h	296M (HD)	1280x720/25 (1:1) - EM	492	3456	3960	13
08h	296M (HD)	1280x720/24 (1:1)	2833	1280	4125	13

Table 3-4: Supported Video Standards (Continued)

VD_STD[4:0]	SMPTE Standard	Video Format	Length of HANC	Length of Active Video	Total Samples	SMPTE352M Lines
09h	296M (HD)	1280x720/24 (1:1) - EM	513	3600	4125	13
0Ah	274M (HD)	1920x1080/60 (2:1) or 1920x1080/30 (PsF)	268	1920	2200	10, 572
0Bh	274M (HD)	1920x1080/30 (1:1)	268	1920	2200	18
0Ch	274M (HD)	1920x1080/50 (2:1) or 1920x1080/25 (PsF)	708	1920	2640	10, 572
0Dh	274M (HD)	1920x1080/25 (1:1)	708	1920	2640	18
0Eh	274M (HD)	1920x1080/25 (1:1) - EM	324	2304	2640	18
0Fh	274M (HD)	1920x1080/25 (PsF) - EM	324	2304	2640	10, 572
10h	274M (HD)	1920x1080/24 (1:1)	818	1920	2750	18
11h	274M (HD)	1920x1080/24 (PsF)	818	1920	2750	10, 572
12h	274M (HD)	1920x1080/24 (1:1) - EM	338	2400	2750	18
13h	274M (HD)	1920x1080/24 (PsF) - EM	338	2400	2750	10, 572
14h	295M (HD)	1920x1080/50 (2:1)	444	1920	2376	10, 572
15h	260M (HD)	1920x1035/60 (2:1)	268	1920	2200	10, 572
16h	125M (SD)	1440x487/60 (2:1) (Or dual link progressive)	268	1440	1716	3, 276
17h	125M (SD)	1440x507/60 (2:1)	268	1440	1716	3, 276
19h	125M (SD)	525-line 487 generic	–	–	1716	3, 276
1Bh	125M (SD)	525-line 507 generic	–	–	1716	3, 276
18h	ITU-R BT.656 (SD)	1440x576/50 (2:1) (Or dual link progressive)	280	1440	1728	9, 322
1Ah	ITU-R BT.656 (SD)	625-line generic (EM)	–	–	1728	9, 322
1Dh	Unknown HD	–	–	–	–	–
1Eh	Unknown SD	–	–	–	–	–
1Ch, 1Fh	Reserved	–	–	–	–	–

NOTE: Though the GS1532 will work correctly on and serialize both 59.94Hz and 60Hz formats, it will not distinguish between them.

3.6.3 Packet Generation and Insertion

In addition to input data blanking and automatic video standards detection, the GS1532 may also calculate, assemble and insert into the data stream various types of ancillary data packets and TRS ID words.

These features are only available when the device is set to operated in SMPTE mode and the IOPROC_EN/DIS pin is set HIGH. Individual insertion features may be enabled or disabled via the IOPROC_DISABLE register (Table 3-5).

All of the IOPROC_DISABLE register bits default to '0' after device reset, enabling all of the processing features. To disable any individual error correction feature, the host interface must set the corresponding bit HIGH in this register.

Table 3-5: Host Interface Description for Internal Processing Disable Register

Register Name	Bit	Name	Description	R/W	Default
IOPROC_DISABLE Address: 000h	15-9	–	Not Used.	–	–
	8	H_CONFIG	Horizontal sync timing input configuration. Set LOW when the H input timing is based on active line blanking (default). Set HIGH when the H input timing is based on the H bit of the TRS words. See Figure 3-2.	R/W	0
	7	–	Not Used.	–	–
	6	352M_INS	SMPTE352M packet insertion. In HD mode, 352M packets are inserted in the Y channel only when one of the bytes in the VIDEO_FORMAT_A or VIDEO_FORMAT_B registers are programmed with non-zero values. The IOPROC_EN/DIS pin and SMPTE_BYPASS pin must also be set HIGH. Set HIGH to disable.	R/W	0
	5	ILLEGAL_REMAP	Illegal Code Remapping. Detection and correction of illegal code words within the active picture area (AP). The IOPROC_EN/DIS pin and SMPTE_BYPASS pin must also be set HIGH. Set HIGH to disable.	R/W	0
	4	EDH_CRC_INS	Error Detection & Handling (EDH) Cyclical Redundancy Check (CRC) error correction. In SD mode the GS1532 will generate and insert EDH packets. The IOPROC_EN/DIS pin and SMPTE_BYPASS pin must also be set HIGH. Set HIGH to disable.	R/W	0
	3	ANC_CSUM_INS	Ancillary Data Checksum insertion. The IOPROC_EN/DIS pin and SMPTE_BYPASS pin must also be set HIGH. Set HIGH to disable.	R/W	0
	2	CRC_INS	Y and C line-based CRC insertion. In HD mode, line-based CRC words are inserted in both the Y and C channels. The IOPROC_EN/DIS pin and SMPTE_BYPASS pin must be also set HIGH. Set HIGH to disable	R/W	0
	1	LNUM_INS	Y and C line number insertion - HD mode only. The IOPROC_EN/DIS pin and SMPTE_BYPASS pin must be set HIGH. Set HIGH to disable.	R/W	0
	0	TRS_INS	Timing Reference Signal Insertion. Occurs only when IOPROC_EN/DIS is HIGH and SMPTE_BYPASS is HIGH. Set HIGH to disable.	R/W	0

3.6.3.1 SMPTE 352M Payload Identifier Insertion

The GS1532 can generate and insert SMPTE 352M payload identifier ancillary data packets into the data stream, based on information programmed into the host interface.

When this feature is enabled, the device will automatically generate the ancillary data preambles, (DID, SDID, DBN, DC), and calculate the checksum. The SMPTE 352M packet will be inserted into the data stream according to the line numbers programmed in the LINE_352M registers (Table 3-6).

The insertion process will only take place if one or more of the four VIDEO_FORMAT registers (Table 3-7) have been programmed with non-zero values. In addition, the GS1532 requires the 352M_INS bit of the IOPROC_DISABLE register be set LOW.

NOTE 1: For the purpose of determining the line and pixel position for insertion, the GS1532 will differentiate between PsF and interlaced formats by interrogating bits 14 and 15 of the VIDEO_FORMAT_A register.

The packets will be inserted immediately after the EAV word in SD video streams and immediately after the line-based CRC word in the Y channel of HD video streams.

NOTE 2: It is the responsibility of the user to ensure that there is sufficient space in the horizontal blanking interval for the insertion of the SMPTE 352M packets.

If there are other ancillary data packets present, the SMPTE 352M packet will be inserted in the first available location in the horizontal ancillary space. Ancillary data must be adjacent to the EAV in SD streams or to the line based-CRC in HD streams. Where there is insufficient space available, the 352M packets will not be inserted.

Table 3-6: Host Interface Description for SMPTE 352M Packet Line Number Insertion Registers

Register Name	Bit	Name	Description	R/W	Default
LINE_352M_f1 Address: 01Bh	15-11	–	Not Used.	–	–
	10-0	LINE_0_352M[10:0]	Line number where SMPTE352M packet is inserted in field 1.	R/W	0
LINE_352M_f2 Address: 01Ch	15-11	–	Not Used.	–	–
	10-0	LINE_1_352M[10:0]	Line number where SMPTE352M packet is inserted in field 2.	R/W	0

Table 3-7: Host Interface Description for SMPTE 352M Payload Identifier Registers

Register Name	Bit	Name	Description	R/W	Default
VIDEO_FORMAT_B Address: 00Bh	15-8	SMPTE352M Byte 4	SMPTE 352M Byte 4 information must be programmed in this register when 352M_INS = LOW.	R/W	0
	7-0	SMPTE352M Byte 3	SMPTE 352M Byte 3 information must be programmed in this register when 352M_INS = LOW.	R/W	0
VIDEO_FORMAT_A Address: 00Ah	15-8	SMPTE352M Byte 2	SMPTE 352M Byte 2 information must be programmed in this register when 352M_INS = LOW.	R/W	0
	7-0	SMPTE 352M Byte 1	SMPTE 352M Byte 1 information must be programmed in this register when 352M_INS = LOW.	R/W	0

3.6.3.2 Illegal Code Remapping

If the ILLEGAL_REMAP bit of the IOPROC_DISABLE register is set LOW, the GS1532 will remap all codes within the active picture between the values of 3FCh and 3FFh to 3FBh. All codes within the active picture area between the values of 000h and 003h will be remapped to 004h.

In addition, 8-bit TRS and ancillary data preambles will be remapped to 10-bit values if this feature is enabled.

3.6.3.3 EDH Generation and Insertion

When operating in SD mode, ($\overline{SD/HD}$ = HIGH), the GS1532 will generate and insert complete EDH packets into the data stream. Packet generation and insertion will only take place if the EDH_CRC_INS bit of the IOPROC_DISABLE register is set LOW.

The GS1532 will generate all of the required EDH packet data including all ancillary data preambles, (DID, DBN, DC), reserved code words and checksum. Calculation of both full field (FF) and active picture (AP) CRC's will be carried out by the device.

SMPTE RP165 specifies the calculation ranges and scope of EDH data for standard 525 and 625 component digital interfaces. The GS1532 will utilize these standard ranges by default.

If the received video format does not correspond to 525 or 625 digital component video standards as determined by the flywheel pixel and line counters, then one of two schemes for determining the EDH calculation ranges will be employed:

1. Ranges will be based on the line and pixel ranges programmed by the host interface; or
2. In the absence of user-programmed calculation ranges, ranges will be determined from the received TRS ID words or supplied H, V, and F timing signals (see [Internal Flywheel on page 27](#)).

The registers available to the host interface for programming EDH calculation ranges include active picture and full field line start and end positions for both fields. Table 3-8 shows the relevant registers, which default to '0' after device reset.

If any or all of these register values are zero, then the EDH CRC calculation ranges will be determined from the flywheel generated H signal. The first active and full field pixel will always be the first pixel after the SAV TRS code word. The last active and full field pixel will always be the last pixel before the start of the EAV TRS code words.

EDH error flags (EDH, EDA, IDH, IDA and UES) for ancillary data, full field and active picture will also be inserted. These flags must be programmed into the EDH_FLAG registers of the device by the application layer (Table 3-9).

NOTE 1: It is the responsibility of the user to ensure that the EDH flag registers are updated once per field.

The prepared EDH packet will be inserted at the appropriate line of the video stream according to RP165. The start pixel position of the inserted packet will be based on the SAV position of that line such that the last byte of the EDH packet (the checksum) will be placed in the sample immediately preceding the start of the SAV TRS word.

NOTE 2: It is also the responsibility of the user to ensure that there is sufficient space in the horizontal blanking interval for the EDH packet to be inserted.

Table 3-8: Host Interface Description for EDH Calculation Range Registers

Register Name	Bit	Name	Description	R/W	Default
AP_LINE_START_F0 Address: 012h	15-10	–	Not Used.	–	–
	9-0	AP_LINE_START_F0[9:0]	Field 0 Active Picture start line data used to set EDH calculation range outside of RP 165 values.	R/W	0
AP_LINE_END_F0 Address: 013h	15-10	–	Not Used.	–	–
	9-0	AP_LINE_END_F0[9:0]	Field 0 Active Picture end line data used to set EDH calculation range outside of RP 165 values.	R/W	0
AP_LINE_START_F1 Address: 014h	15-10	–	Not Used.	–	–
	9-0	AP_LINE_START_F1[9:0]	Field 1 Active Picture start line data used to set EDH calculation range outside of RP 165 values.	R/W	0
AP_LINE_END_F1 Address: 015h	15-10	–	Not Used.	–	–
	9-0	AP_LINE_END_F1[9:0]	Field 1 Active Picture end line data used to set EDH calculation range outside of RP 165 values.	R/W	0

Table 3-8: Host Interface Description for EDH Calculation Range Registers (Continued)

Register Name	Bit	Name	Description	R/W	Default
FF_LINE_START_F0 Address: 016h	15-10	–	Not Used.	–	–
	9-0	FF_LINE_START_F0[9:0]	Field 0 Full Field start line data used to set EDH calculation range outside of RP 165 values.	R/W	0
FF_LINE_END_F0 Address: 017h	15-10	–	Not Used.	–	–
	9-0	FF_LINE_END_F0[9:0]	Field 0 Full Field end line data used to set EDH calculation range outside of RP 165 values.	R/W	0
FF_LINE_START_F1 Address: 018h	15-10	–	Not Used.	–	–
	9-0	FF_LINE_START_F1[9:0]	Field 1 Full Field start line data used to set EDH calculation range outside of RP-165 values.	R/W	0
FF_LINE_END_F1 Address: 019h	15-10	–	Not Used.	–	–
	9-0	FF_LINE_END_F1[9:0]	Field 1 Full Field end line data used to set EDH calculation range outside of RP-165 values.	R/W	0

Table 3-9: Host Interface Description for EDH Flag Register

Register Name	Bit	Name	Description	R/W	Default
EDH_FLAG Address: 002h	15	–	Not Used.	–	–
	14	ANC-UES	Ancillary Unknown Error Status flag will be generated and inserted when IOPROC_EN/DIS and SMPTE_BYPASS pins are HIGH and EDH_CRC_INS bit is LOW. SD mode only.	R/W	0
	13	ANC-IDA	Ancillary Internal device error Detected Already flag will be generated and inserted when IOPROC_EN/DIS and SMPTE_BYPASS pins are HIGH and EDH_CRC_INS bit is LOW. SD mode only.	R/W	0
	12	ANC-IDH	Ancillary Internal device error Detected Here flag will be generated and inserted when IOPROC_EN/DIS and SMPTE_BYPASS pins are HIGH and EDH_CRC_INS bit is LOW. SD mode only.	R/W	0
	11	ANC-EDA	Ancillary Error Detected Already flag will be generated and inserted when IOPROC_EN/DIS and SMPTE_BYPASS pins are HIGH and EDH_CRC_INS bit is LOW. SD mode only.	R/W	0
	10	ANC-EDH	Ancillary Error Detected Here flag will be generated and inserted when IOPROC_EN/DIS and SMPTE_BYPASS pins are HIGH and EDH_CRC_INS bit is LOW. SD mode only.	R/W	0
	9	FF-UES	Full Field Unknown Error flag will be generated and inserted when IOPROC_EN/DIS and SMPTE_BYPASS pins are HIGH and EDH_CRC_INS bit is LOW. SD mode only.	R/W	0

Table 3-9: Host Interface Description for EDH Flag Register (Continued)

Register Name	Bit	Name	Description	R/W	Default
	8	FF-IDA	Full Field Internal device error Detected Already flag will be generated and inserted when IOPROC_EN/DIS and SMPTE_BYPASS pins are HIGH and EDH_CRC_INS bit is LOW. SD mode only.	R/W	0
	7	FF-IDH	Full Field Internal device error Detected flag will be generated and inserted when IOPROC_EN/DIS and SMPTE_BYPASS pins are HIGH and EDH_CRC_INS bit is LOW. SD mode only.	R/W	0
	6	FF-EDA	Full Field Error Detected Already flag will be generated and inserted when IOPROC_EN/DIS and SMPTE_BYPASS pins are HIGH and EDH_CRC_INS bit is LOW. SD mode only.	R/W	0
	5	FF-EDH	Full Field Error Detected Here flag will be generated and inserted when IOPROC_EN/DIS and SMPTE_BYPASS pins are HIGH and EDH_CRC_INS bit is LOW. SD mode only.	R/W	0
	4	AP-UES	Active Picture Unknown Error Status flag will be generated and inserted when IOPROC_EN/DIS and SMPTE_BYPASS pins are HIGH and EDH_CRC_INS bit is LOW. SD mode only.	R/W	0
	3	AP-IDA	Active Picture Internal device error Detected Already flag will be generated and inserted when IOPROC_EN/DIS and SMPTE_BYPASS pins are HIGH and EDH_CRC_INS bit is LOW. SD mode only.	R/W	0
	2	AP-IDH	Active Picture Internal device error Detected Here flag will be generated and inserted when IOPROC_EN/DIS and SMPTE_BYPASS pins are HIGH and EDH_CRC_INS bit is LOW. SD mode only.	R/W	0
	1	AP-EDA	Active Picture Error Detected Already flag will be generated and inserted when IOPROC_EN/DIS and SMPTE_BYPASS pins are HIGH and EDH_CRC_INS bit is LOW. SD mode only.	R/W	0
	0	AP-EDH	Active Picture Error Detected Here flag will be generated and inserted when IOPROC_EN/DIS and SMPTE_BYPASS pins are HIGH and EDH_CRC_INS bit is LOW. SD mode only.	R/W	0

3.6.3.4 Ancillary Data Checksum Generation and Insertion

The GS1532 will calculate checksums for all detected ancillary data packets presented to the device. These calculated checksum values are inserted into the data stream prior to serialization.

Ancillary data checksum generation and insertion will only take place if the ANC_CSUM_INS bit of the IOPROC_DISABLE register is set LOW.

3.6.3.5 Line Based CRC Generation and Insertion

The GS1532 will generate and insert line based CRC words into both the Y and C channels of the data stream. This feature is only available in HD mode and is enabled by setting the CRC_INS bit of the IOPROC_DISABLE register LOW.

3.6.3.6 HD Line Number Generation and Insertion

In HD mode, the GS1532 will calculate and insert line numbers into the Y and C channels of the output data stream.

Line number generation is in accordance with the relevant HD video standard as determined by the device, (see [Automatic Video Standard Detection on page 30](#)).

This feature is enabled when $\overline{\text{SD/HD}} = \text{LOW}$, and the LNUM_INS bit of the IOPROC_DISABLE register is set LOW.

3.6.3.7 TRS Generation and Insertion

The GS1532 can generate and insert 10-bit TRS code words into the data stream as required. This feature is enabled by setting the TRS_INS bit of the IOPROC_DISABLE register LOW.

TRS word generation will be performed in accordance with the timing parameters generated by the flywheel which will be locked either to the received TRS ID words or the supplied H, V, and F timing signals (see [Internal Flywheel on page 27](#)).

3.7 Parallel-To-Serial Conversion

The parallel data output of the internal data processing blocks is fed to the parallel-to-serial converter. The function of this block is to generate a serial data stream from the 10-bit or 20-bit parallel data words and pass the stream to the integrated cable driver.

3.8 Serial Digital Data PLL

To obtain a clean clock signal for serialization and transmission, the input PCLK is locked to an external reference signal via the GS1532's integrated phase-locked loop. This PLL is also responsible for generating all internal clock signals required by the device.

Internal division ratios for the locked PCLK are determined by the setting of the SD/HD and 20bit/10bit pins as shown in [Table 3-10](#).

Table 3-10: Serial Digital Output Rates

Supplied PCLK Rate	Serial Digital Output Rate	Pin Settings	
		SD/HD	20bit/10bit
74.25 or 74.25/1.001 MHz	1.485 or 1.485/1.001Gb/s	LOW	HIGH
148.5 or 148.5/1.001MHz	1.485 or 1.485/1.001Gb/s	LOW	LOW
13.5MHz	270Mb/s	HIGH	HIGH
27MHz	270Mb/s	HIGH	LOW

3.8.1 External VCO

The GS1532 requires the GO1555/GO1525* external voltage controlled oscillator as part of its internal PLL.

Power for the external VCO is generated entirely by the GS1532 from an integrated voltage regulator. The internal regulator uses +3.3V supplied on the CP_VDD / CP_GND pins to provide +2.5V on the VCO_VCC / VCO_GND pins.

The external VCO produces a 1.485GHz reference signal for the PLL, input on the VCO pin of the device. Both reference and control signals should be referenced to the supplied VCO_GND as shown in the recommended application circuit of [Typical Application Circuit on page 47](#).

*For new designs use GO1555

3.8.2 Lock Detect Output

The lock detect block controls the serial digital output signal and indicates to the application layer the lock status of the device via the LOCKED output pin.

LOCKED will be asserted HIGH if and only if the internal data PLL has locked the PCLK signal to the external VCO reference signal and one of the following is true:

1. The device is set to operate in SMPTE mode and has detected SMPTE TRS words in the serial stream; or
2. The device is set to operate in DVB-ASI mode and has detected K28.5 sync characters in the serial stream; or

- The device is set to operate in Data-Through mode.

3.8.3 Loop Bandwidth Adjustment

For new designs the GO1555 is recommended for use with the GS1532. The recommended application circuit can be seen in [Section 4.1 Typical Application Circuit](#).

Designs using the GO1525 VCO use different loop bandwidth components. The application circuit is shown in [Figure 3-4](#).

NOTE: When using the GS1532 with the GS4911B clock generator a narrower loop bandwidth for the GS1532 serializer should be used. For more details please refer to section 2.5 of the GS4911B Reference Design.

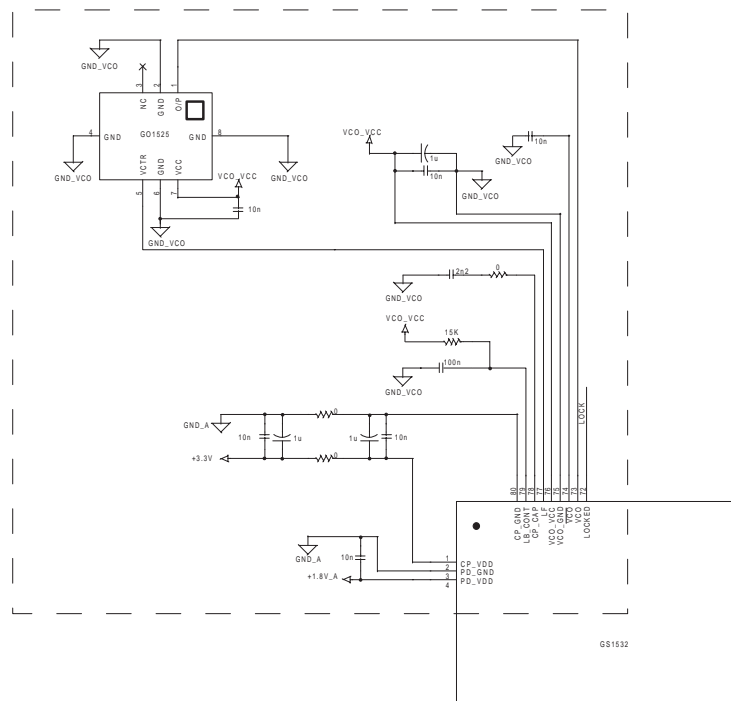

Figure 3-4: Typical Application Circuit using GO1525

3.9 Serial Digital Output

The GS1532 contains an integrated current mode differential serial digital cable driver with automatic slew rate control.

To enable the output, $\overline{\text{SDO_EN/DIS}}$ must be set HIGH by the application layer. Setting the SDO_EN/DIS signal LOW will cause the SDO and $\overline{\text{SDO}}$ output pins to become high impedance, resulting in reduced device power consumption.

With suitable external return loss matching circuitry, the GS1532's serial digital outputs will provide a minimum output return loss of -15dB at SD rates. Gennum recommends using the GS1528 SDI Dual Slew-Rate Cable Driver to meet output return loss specifications at HD rates.

The integrated cable driver uses a separate power supply of +1.8V DC supplied via the CD_VDD and CD_GND pins.

3.9.1 Output Swing

Nominally, the voltage swing of the serial digital output is 800mVp-p single-ended into a 75Ω load. This is set externally by connecting the RSET pin to CD_VDD through 281Ω.

The output swing may be decreased by increasing the value of the RSET resistor. The relationship is approximated by the curve shown in [Figure 3-5](#).

Alternatively, the serial digital output swing can drive 800mVp-p into a 50Ω load. Since the output swing is reduced by a factor of approximately one third when the smaller load is used, the RSET resistor must be 187Ω to obtain 800mVp-p.

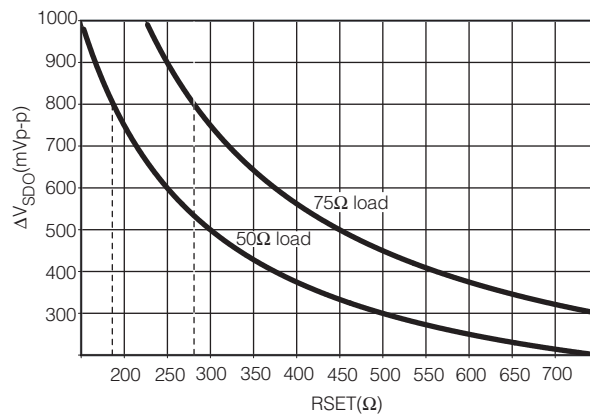

Figure 3-5: Serial Digital Output Swing

3.9.2 Serial Digital Output Mute

The GS1532 will automatically mute the serial digital output when the LOCKED output signal is LOW. In this case, the SDO and $\overline{\text{SDO}}$ signals are set to a constant voltage level.

3.10 GSPI Host Interface

The GSPI, or Genum Serial Peripheral Interface, is a 4-wire interface provided to allow the host to enable additional features of the device and /or to provide additional status information through configuration registers in the GS1532.

The GSPI comprises a serial data input signal SDIN, serial data output signal SDO_{OUT}, an active low chip select $\overline{\text{CS}}$, and a burst clock SCLK. The burst clock must have a duty cycle between 40% and 60%.

Because these pins are shared with the JTAG interface port, an additional control signal pin JTAG/ $\overline{\text{HOST}}$ is provided. When JTAG/ $\overline{\text{HOST}}$ is LOW, the GSPI interface is enabled.

When operating in GSPI mode, the SCLK, SDIN, and \overline{CS} signals are provided by the host interface. The SDOOUT pin is a high-impedance output allowing multiple devices to be connected in parallel and selected via the \overline{CS} input. The interface is illustrated in the Figure 3-6 below.

All read or write access to the GS1532 is initiated and terminated by the host processor. Each access always begins with a 16-bit command word on SDIN indicating the address of the register of interest. This is followed by a 16-bit data word on SDIN in write mode, or a 16-bit data word on SDOOUT in read mode.

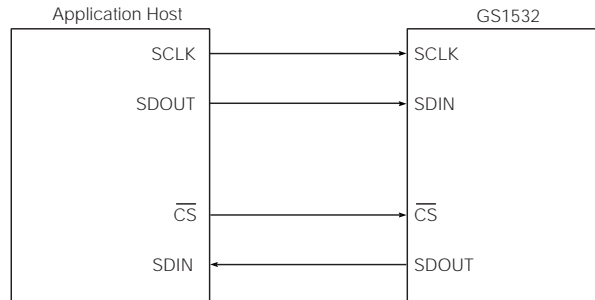

Figure 3-6: Genum Serial Peripheral Interface (GSPI)

3.10.1 Command Word Description

The command word is transmitted MSB first and contains a read/write bit, nine reserved bits and a 6-bit register address. Set R/W = '1' to read and R/W = '0' to write from the GSPI.

Command words are clocked into the GS1532 on the rising edge of the serial clock SCLK. The appropriate chip select signal, \overline{CS} , must be asserted low a minimum of 1.5ns (t_0 in Figure 3-9 and Figure 3-10) before the first clock edge to ensure proper operation.

Each command word must be followed by only one data word to ensure proper operation.



Figure 3-7: Command Word

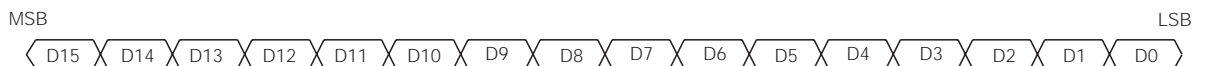

Figure 3-8: Data Word

3.10.2 Data Read and Write Timing

Read and write mode timing for the GSPI interface is shown in Figure 3-9 and Figure 3-10 respectively. The maximum SCLK frequency allowed is 6.6MHz.

When writing to the registers via the GSPI, the MSB of the data word may be presented to SDIN immediately following the falling edge of the LSB of the command word. All SDIN data is sampled on the rising edge of SCLK.

When reading from the registers via the GSPI, the MSB of the data word will be available on SDOUT 12ns (t_5) following the falling edge of the LSB of the command word, and thus may be read by the host on the very next rising edge of the clock. The remaining bits are clocked out by the GS1532 on the negative edges of SCLK.

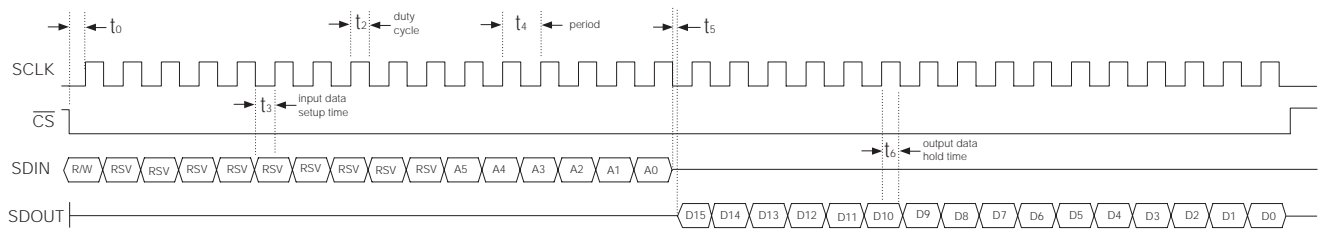

Figure 3-9: GSPI Read Mode Timing

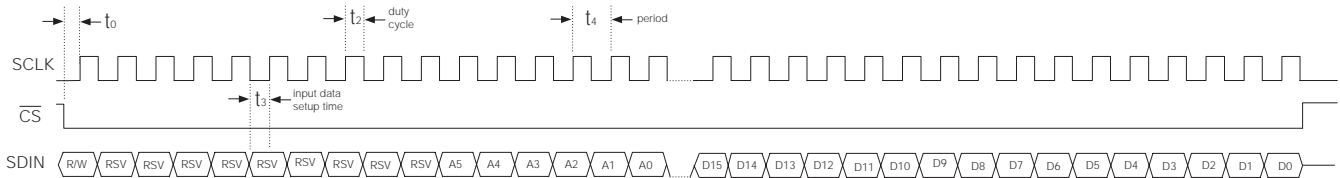

Figure 3-10: GSPI Write Mode Timing

3.10.3 Configuration and Status Registers

Table 3-11 summarizes the GS1532's internal status and configuration registers.

All of these registers are available to the host via the GSPI and are all individually addressable.

Where status registers contain less than the full 16 bits of information, two or more registers may be combined at a single logical address.

Table 3-11: GS1532 Internal Registers

Address	Register Name	See Section
000h	IOPROC_DISABLE	Section 3.6.3
002h	EDH_FLAG	Section 3.6.3.3
004h	VIDEO_STANDARD	Section 3.6.2
00Ah - 00Bh	VIDEO_FORMAT	Section 3.6.3.1
00Eh - 011h	RASTER_STRUCTURE	Section 3.6.2
012h - 019h	EDH_CALC_RANGES	Section 3.6.3.3
01Bh - 01Ch	LINE_352M	Section 3.6.3.1

3.11 JTAG

When the $\overline{\text{JTAG_HOST}}$ input pin of the GS1532 is set HIGH, the host interface port will be configured for JTAG test operation. In this mode, pins 27 through 30 become TMS, TDO, TDI, and TCK. In addition, the $\overline{\text{RESET_TRST}}$ pin will operate as the test reset pin.

Boundary scan testing using the JTAG interface will be enabled in this mode.

There are two methods in which JTAG can be used on the GS1532:

1. As a stand-alone JTAG interface to be used at in-circuit ATE (Automatic Test Equipment) during PCB assembly; or
2. Under control of the host for applications such as system power on self tests.

When the JTAG tests are applied by ATE, care must be taken to disable any other devices driving the digital I/O pins. If the tests are to be applied only at ATE, this can be accomplished with tri-state buffers used in conjunction with the $\overline{\text{JTAG_HOST}}$ input signal. This is shown in [Figure 3-11](#).

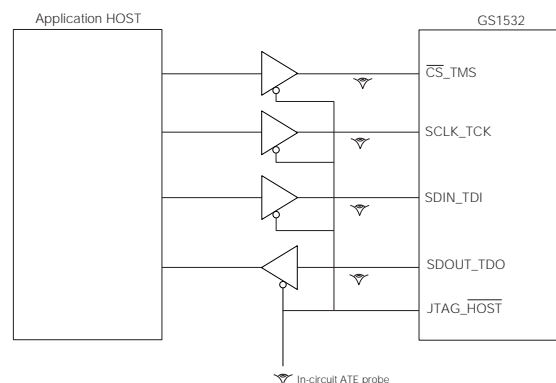

Figure 3-11: In-Circuit JTAG

Alternatively, if the test capabilities are to be used in the system, the host may still control the JTAG/HOST input signal, but some means for tri-stating the host must exist in order to use the interface at ATE. This is represented in Figure 3-12.

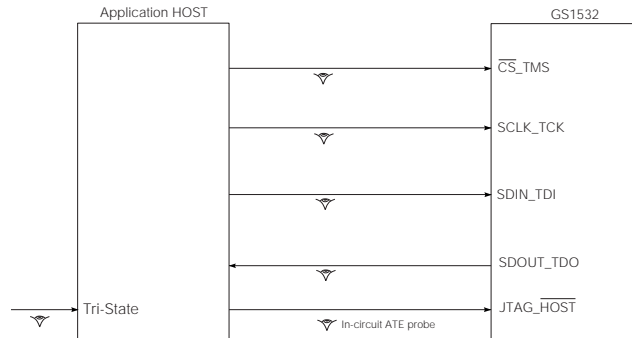

Figure 3-12: System JTAG

Please contact your Gennum representative to obtain the BSDL model for the GS1532.

3.12 Device Power Up

The GS1532 has a recommended power supply sequence. To ensure correct power up, power the CORE_VDD pins before the IO_VDD pins.

Device pins may also be driven prior to power up without causing damage.

To ensure that all internal registers are cleared upon power-up, the application layer must hold the RESET_TRST signal LOW for a minimum of 1ms after the core power supply has reached the minimum level specified in the DC Electrical Characteristics Table, (Table 2-1). See Figure 3-13.

3.13 Device Reset

In order to initialize all internal operating conditions to their default states the application layer must hold the RESET_TRST signal LOW for a minimum of $t_{reset} = 1ms$.

When held in reset, all device outputs will be driven to a high-impedance state.

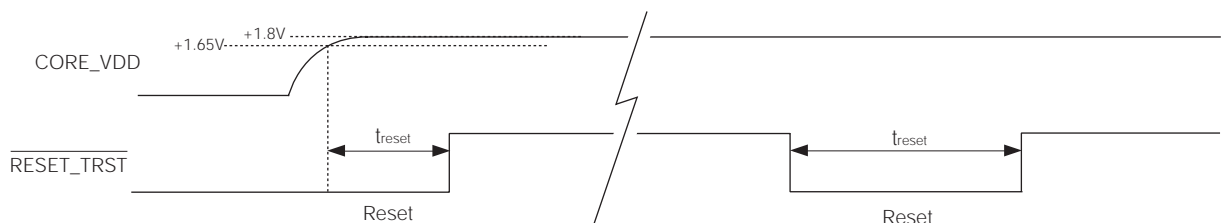
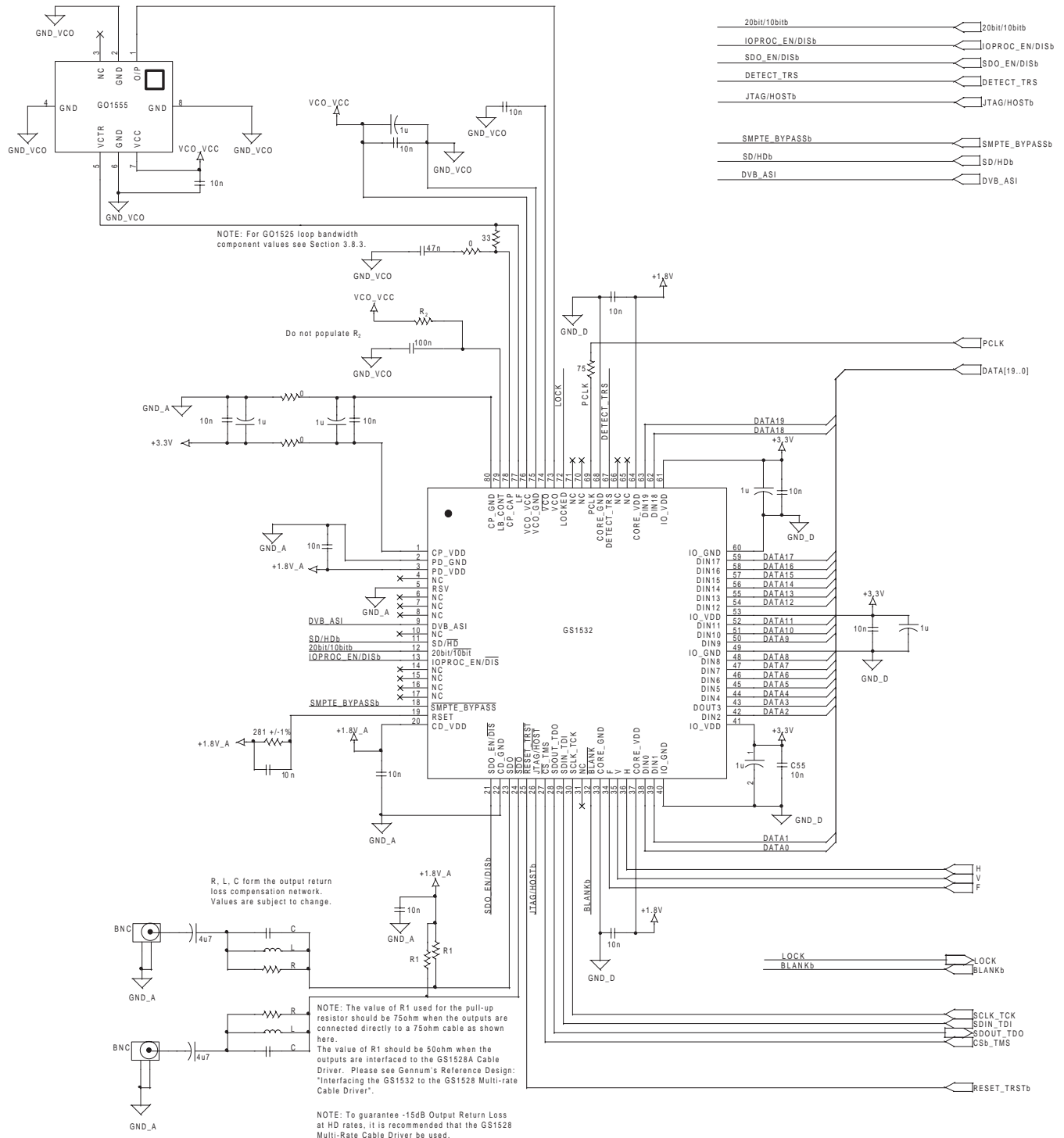

Figure 3-13: Reset Pulse

4. Application Reference Design

4.1 Typical Application Circuit



5. References & Relevant Standards

SMPTE 125M	Component video signal 4:2:2 – bit parallel interface
SMPTE 260M	1125 / 60 high definition production system – digital representation and bit parallel interface
SMPTE 267M	Bit parallel digital interface – component video signal 4:2:2 16 x 9 aspect ratio
SMPTE 274M	1920 x 1080 scanning analog and parallel digital interfaces for multiple picture rates
SMPTE 291M	Ancillary Data Packet and Space Formatting
SMPTE 292M	Bit-Serial Digital Interface for High-Definition Television Systems
SMPTE 293M	720 x 483 active line at 59.94 Hz progressive scan production – digital representation
SMPTE 296M	1280 x 720 scanning, analog and digital representation and analog interface
SMPTE 352M	Video Payload Identification for Digital Television Interfaces
SMPTE RP165	Error Detection Checkwords and Status Flags for Use in Bit-Serial Digital Interfaces for Television
SMPTE RP168	Definition of Vertical Interval Switching Point for Synchronous Video Switching

6. Package & Ordering Information

6.1 Package Dimensions

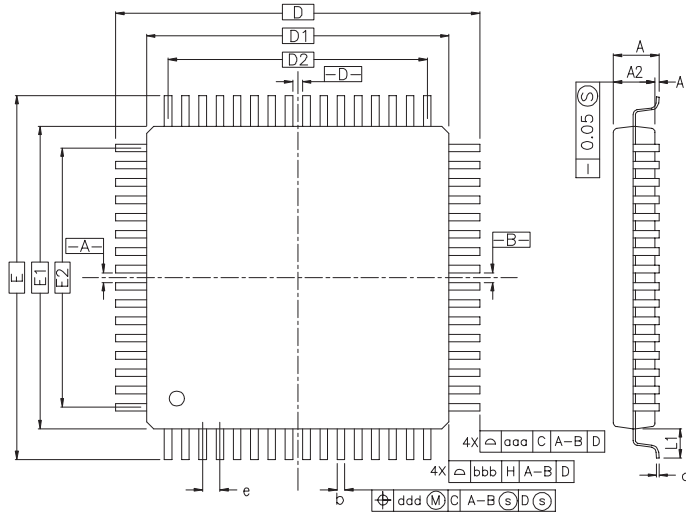

Table X

SYMBOL	MILLIMETER			INCH		
	MIN.	NOM.	MAX.	MIN.	NOM.	MAX.
A	—	—	1.60	—	—	0.063
A1	0.05	—	0.15	0.002	—	0.006
A2	1.35	1.40	1.45	0.053	0.055	0.057
D	16.00 BSC.			0.630 BSC.		
D1	14.00 BSC.			0.551 BSC.		
E	16.00 BSC.			0.630 BSC.		
E1	14.00 BSC.			0.551 BSC.		
R2	0.08	—	0.20	0.003	—	0.008
R1	0.08	—	—	0.003	—	—
θ	0°	3.5°	7°	0°	3.5°	7°
θ_1	0°	—	—	0°	—	—
θ_2	11°	12°	13°	11°	12°	13°
θ_3	11°	12°	13°	11°	12°	13°
c	0.09	—	0.20	0.004	—	0.008
L	0.45	0.60	0.75	0.018	0.024	0.030
L1	1.00 REF			0.039 REF		
S	0.20	—	—	0.008	—	—

CONTROL DIMENSIONS ARE IN MILLIMETERS.

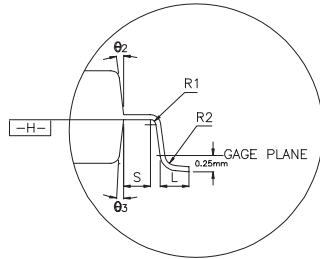
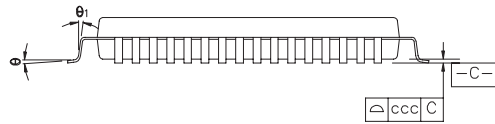

Table Y

SYMBOL	80L					
	MILLIMETER			INCH		
	MIN	NOM	MAX	MIN	NOM	MAX
b	0.22	0.30	0.38	0.009	0.012	0.015
e	0.65 BSC			0.026 BSC		
D2	12.35			0.486		
E2	12.35			0.486		
TOLERANCES OF FORM AND POSITION						
aaa	0.20			0.008		
bbb	0.20			0.008		
ccc	0.10			0.004		
ddd	0.13			0.005		

NOTES:

Diagram shown is representative only. Table X is fixed for all pin sizes, and Table Y is specific to the 80-pin package.

1. DIMENSIONS D1 AND E1 DO NOT INCLUDE MOLD PROTRUSION. ALLOWABLE PROTRUSION IS 0.25mm PER SIDE. D1 AND E1 ARE MAXIMUM PLASTIC BODY SIZE DIMENSIONS INCLUDING MOLD MISMATCH.
2. DIMENSION b DOES NOT INCLUDE DAMBAR PROTRUSION. ALLOWABLE DAMBAR PROTRUSION SHALL NOT CAUSE THE LEAD WIDTH TO EXCEED THE MAXIMUM b DIMENSION BY MORE THAN 0.08mm. DAMBAR CAN NOT BE LOCATED ON THE LOWER RADIUS OR THE FOOT. MINIMUM SPACE BETWEEN PROTRUSION AND AN ADJACENT LEAD IS 0.07mm FOR 0.4mm AND 0.5mm PITCH PACKAGES.

6.2 Packaging Data

Parameter	Value
Package Type	14mm x 14mm 80-pin LQFP
Package Drawing Reference	JEDEC MS026
Moisture Sensitivity Level	3
Junction to Case Thermal Resistance, θ_{j-c}	11.6°C/W
Junction to Air Thermal Resistance, θ_{j-a} (at zero airflow)	39.9°C/W
Psi	0.6°C/W
Pb-free and RoHS Compliant (GS1532-CFE3)	Yes

6.3 Ordering Information

Part Number	Pb-free and RoHS Compliant	Package	Temperature Range
GS1532-CF	No	80-pin LQFP	0°C to 70°C
GS1532-CFE3	Yes	80-pin LQFP	0°C to 70°C

7. Revision History

Version	ECR	PCN	Date	Changes and / or Modifications
3	133556	–	March 2004	Register addresses in Tables 2, 3, 5, 6, 7, 8, 9 and 11 are shown in DECIMAL. They should be shown in HEX (as per master Table in Section 2.5). Pins 65 and 66 were not shown on Pin Description Table.
4	133860	–	May 2004	Converted GS1532 data sheet to new template format. Added note to host interface pins. Moved ESD to maximum absolute ratings. Adjusted Input Data Setup Time in AC Electrical Characteristics. Text in Table 4-2 and text in section 4.6.2.1 changed to read "INT_PROG" and "Interlace/Progressive: Set LOW if detected video standard is PROGRESSIVE and is set HIGH if it is INTERLACED". Added Pb-free and Green availability and ordering information. Corrected minor typing errors.
5	134909	–	April 2005	Updated document status to Data Sheet. Added description to Solder Reflow Profiles. Clarified setting of VD_STD[4:0], INT_PROG and STD_LOCK bits following a reset and/or removal of PCLK. Modified Typical Application Circuit to add interfacing note for GS1532 to GS1528A Cable Driver. Added Packaging Data section. Changed 'Green' references to RoHS Compliant.
6	136983	–	June 2005	Restored missing overlines to pin names. Rephrased RoHS compliance statement. Added note on 59.94Hz and 60Hz formats to Table 3-4.
7	142223	41245	October 2006	Modified internal register addresses to hexadecimal values in Table 3-11 . Added built-in ClockCleaner™ feature to document title and functional block diagram. Specified that serializer can reject >300ps pclk jitter in Description section on page 1 . Corrected VIDEO_FORMAT register labels in description of bit 6 (352M_INS) in Table 3-5 .
8	143760	42774	February 2007	Recommended GO1555 VCO for new designs. Updated Section 4.1 Typical Application Circuit . Added Section 3.8.3 Loop Bandwidth Adjustment .

CAUTION

ELECTROSTATIC SENSITIVE DEVICES
DO NOT OPEN PACKAGES OR HANDLE
EXCEPT AT A STATIC-FREE WORKSTATION

DOCUMENT IDENTIFICATION
DATA SHEET

The product is in production. Gennum reserves the right to make changes at any time to improve reliability, function or design, in order to provide the best product possible.

GENNUM CORPORATION

Mailing Address: P.O. Box 489, Stn. A, Burlington, Ontario, Canada L7R 3Y3
Shipping Address: 970 Fraser Drive, Burlington, Ontario, Canada L7L 5P5
Tel. +1 (905) 632-2996 Fax. +1 (905) 632-5946

GENNUM JAPAN CORPORATION

Shinjuku Green Tower Building 27F, 6-14-1, Nishi Shinjuku, Shinjuku-ku, Tokyo, 160-0023 Japan
Tel. +81 (03) 3349-5501, Fax. +81 (03) 3349-5505

GENNUM UK LIMITED

25 Long Garden Walk, Farnham, Surrey, England GU9 7HX
Tel. +44 (0)1252 747 000 Fax +44 (0)1252 726 523

Gennum Corporation assumes no liability for any errors or omissions in this document, or for the use of the circuits or devices described herein. The sale of the circuit or device described herein does not imply any patent license, and Gennum makes no representation that the circuit or device is free from patent infringement.

GENNUM and the G logo are registered trademarks of Gennum Corporation.

© Copyright 2002 Gennum Corporation. All rights reserved. Printed in Canada.

www.gennum.com