

M8050

NPN TRANSISTOR



VOLTAGE: 25 Volts

CURRENT: 1.0 Amperes

SOT-23

Marking and Polarity

FEATURES

- NPN Low Frequency Power Amplifier
- Suitable for Driver Stage of Small Motor

MECHANICAL DATA

- **Package:** SOT-23
- **Epoxy UL:** 94V-0
- **Mounting position:** Any
- **Weight:** approx. 0.01g

DEVICE MARKING

Device	Marking
M8050	Y1.

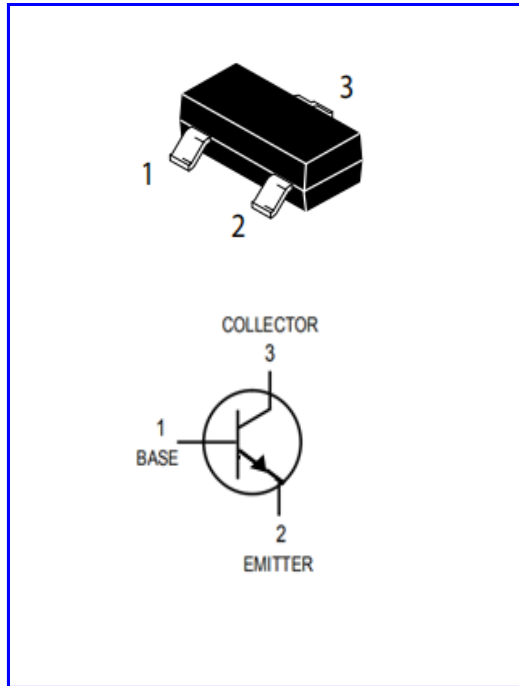

Maximum Ratings (Ratings at 25°C ambient temperature unless otherwise specified.)

Parameter	Symbol	Value	Unit
Collector-Base Voltage	V_{CBO}	40	V
Collect-Emitter Voltage	V_{CEO}	25	V
Emitter-Base Voltage	V_{EBO}	5	V
Collector Current	I_C	1.0	A
Collector Power Dissipation	P_C	300	mW

Thermal Characteristics (Ratings at 25°C ambient temperature unless otherwise specified.)

Junction Temperature	T_J	-55 to 150	°C
Storage Temperature Range	T_{STG}	-55 to 150	°C
Typical thermal resistance	$R_{\theta JA}$	417	°C/W

M8050
NPN TRANSISTOR



ELECTRICAL CHARACTERISTICS ($T_A=25^\circ\text{C}$ unless otherwise noted)

Characteristic	Test Condition	Symbol	Min.	Typ.	Max.	Unit
Collector-Emitter Breakdown Voltage	$I_C=10\text{mA}, I_B=0$	$V_{(BR)CEO}$	25	-	-	V
Collector-Base Breakdown Voltage	$I_C=100\mu\text{A}, I_E=0$	$V_{(BR)CBO}$	40	-	-	V
Emitter-Base Breakdown Voltage	$I_E=100\mu\text{A}, I_C=0$	$V_{(BR)EBO}$	5	-	-	V
Collector Cutoff Current	$V_{CB}=30\text{V}, I_E=0$	I_{CBO}	-	-	0.1	μA
Emitter Cutoff Current	$V_{EB}=5\text{V}, I_C=0$	I_{EBO}	-	-	0.1	μA
DC Current Gain	$V_{CE}=1\text{V}, I_C=1\text{A}$	H_{FE}	40	-	-	
Collector-Emitter Saturation Voltage	$I_C=1\text{A}, I_B=100\text{mA}$	$V_{CE(Sat)}$	-	-	0.6	V
Base-Emitter Saturation Voltage	$I_C=10\text{mA}, I_B=1\text{A}$	$V_{BE(Sat)}$	-	0.8	1	V
Transition Frequency	$V_{CB}=10\text{V}, I_E=0$, $f=1\text{MHz}$	F_T	100	120	-	MHz

M8050
NPN TRANSISTOR



OUTLINE DRAWINGS

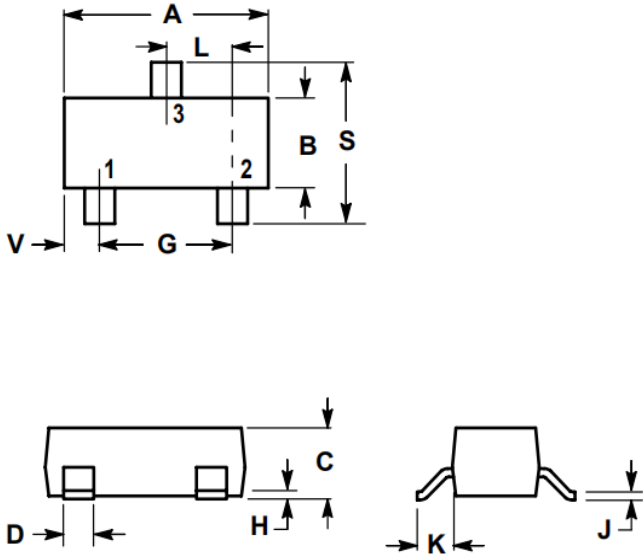

SOT-23

OUTLINE DIMENSIONS						
Dim.	Millimeters			Inches		
	Min.	Typ.	Max.	Min.	Typ.	Max.
A	2.800	-	3.040	0.1102	-	0.1197
B	1.200	-	1.400	0.0472	-	0.0551
C	0.890	-	1.110	0.0350	-	0.0437
D	0.370	-	0.500	0.0146	-	0.0197
G	1.780	-	2.040	0.0701	-	0.0803
H	0.013	-	0.100	0.0005	-	0.0039
J	0.085	-	0.177	0.0033	-	0.0070
K	0.350	-	0.690	0.0138	-	0.0272
L	0.890	-	1.020	0.0350	-	0.0402
S	2.100	-	2.640	0.0827	-	0.1039
V	0.450	-	0.600	0.0177	-	0.0236

MOUNTING PAD LAYOUT

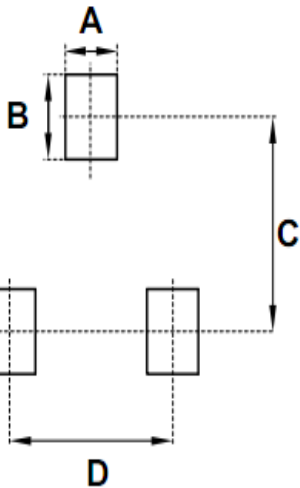

SOT-23

RECOMMENDED MOUNTING PAD DIMENSIONS						
Dim.	Millimeters			Inches		
	Min.	Typ.	Max.	Min.	Typ.	Max.
A	-	0.600	-	-	0.0236	-
B	-	0.800	-	-	0.0315	-
C	-	2.020	-	-	0.0795	-
D	-	1.900	-	-	0.0748	-

PACKING INFORMATION

SOT-23

Package Method	Reel Size (mm)	Quantity (pcs/reel)	Inner Box Size LxWxH(mm)	Quantity (pcs/Inner Box)	Carton Size LxWxH(mm)	Quantity (pcs/carton)
Tape Reel	Φ180	3000	340x340x40	6000	364x364x360	160000

M8050
NPN TRANSISTOR



Recommended wave soldering condition

Product	Peak Temperature	Soldering Time
Pb-free devices	260 +0/-5 °C	5 +1/-1 seconds

Recommended temperature profile for IR reflow

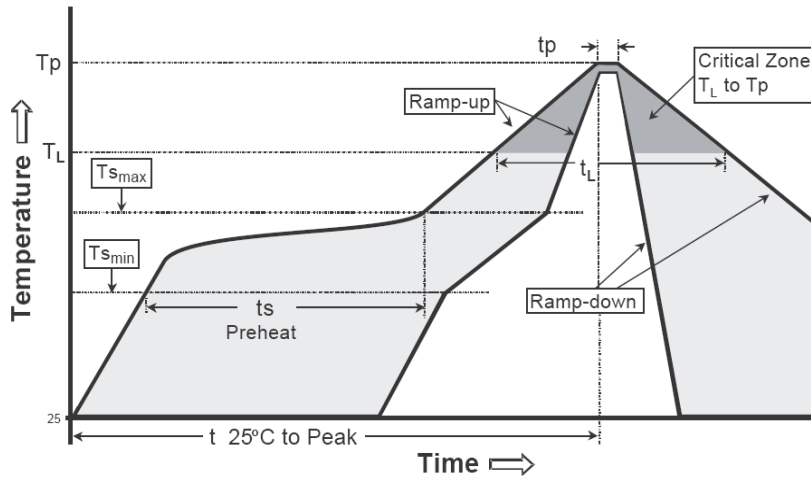

Profile feature	Sn-Pb eutectic Assembly	Pb-free Assembly
Average ramp-up rate (T _{smax} to T _p)	3°C/second max.	3°C/second max.
Preheat -Temperature Min(TS min) -Temperature Max(TS max) -Time(ts min to ts max)	100°C 150°C 60-120 seconds	150°C 200°C 60-180 seconds
Time maintained above: -Temperature (T _l) - Time (t _l)	183°C 60-150 seconds	217°C 60-150 seconds
Peak Temperature(T _p)	240 +0/-5 °C	260 +0/-5 °C
Time within 5°C of actual peak temperature(tp)	10-30 seconds	20-40 seconds
Ramp down rate	6°C/second max.	6°C/second max.
Time 25 °C to peak temperature	6 minutes max.	8 minutes max.

Note : All temperatures refer to topside of the package, measured on the package body surface.

M8050

NPN TRANSISTOR



Disclaimer

- Reproducing and modifying information of the document is prohibited without permission from niuhang electronics co., LTD.
- Niuhan Electronics co., LTD. reserves the rights to make changes of the content herein the document anytime without notification.
- Niuhan Electronics co., LTD. disclaims any and all liability arising out of the application or use of any product including damages incidentally and consequentially occurred.
- Niuhan Electronics co., LTD. does not assume any and all implied warranties, including warranties of fitness for particular purpose, non-infringement and merchantability.
- Applications shown on the herein document are examples of standard use and operation. Customers are responsible in comprehending the suitable use in particular applications. Niuhan Electronics co., LTD. makes no representation or warranty that such applications will be suitable for the specified use without further testing or modification.
- The products shown herein are not designed and authorized for equipments requiring high level of reliability or relating to human life and for any applications concerning life-saving or life-sustaining, such as medical instruments, transportation equipment, aerospace machinery et cetera. Customers using or selling these products for use in such applications do so at their own risk and agree to fully indemnify Niuhan Electronics co., LTD. for any damages resulting from such improper use or sale.
- When the appearance of the product and chip size does not change, in order to product the customer. quality, change the internal structure and the production process niuhang can not notify