

REACH & RoHS
COMPLIANT

REV.	ECN / DESCRIPTION	BY	DATE
A0	NEW	MQ.QU	2018.04.14
A1	Dimensional change	ZG.HU	2020.10.12

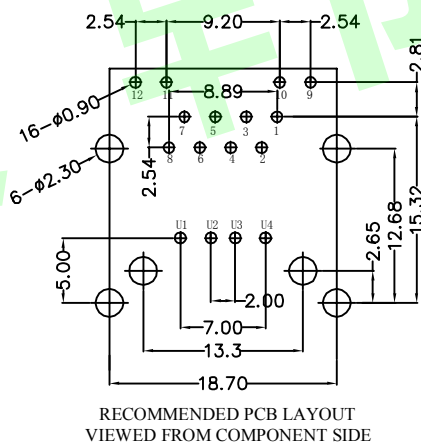
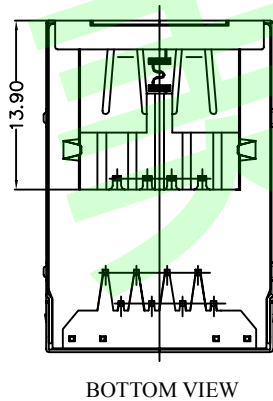
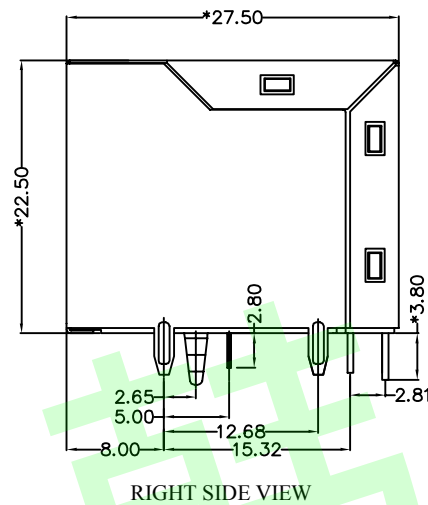
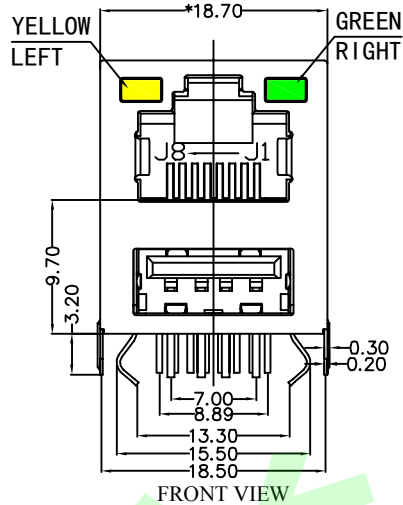

MATERIAL:

RJ45:
HOUSING: PBT,UL94V-0,BLACK.
TERMINAL: PHOSPHOR BRONZE Ø=0.46MM, G/FU" GOLD PLATING.

USB:

HOUSING: PBT,UL94V-0,WHITE.
RJ45 TERMINAL: PHOSPHOR BRONZE T=0.25MM, G/FU" GOLD PLATING.
SHIELD: ALLOY.

MACHANICAL:

DURABILITY: 750 CYCLES MIN,12.5MM/MINUTE.
INSERTION FORCE: 2.2KG.F MAX.
RETENTION STRENGTH : 7.7KG.F BETWEEN JACK AND PLUG.
OPERATING TEMPERATURE: -40°C~+85°C.
STORAGE TEMPERATURE: -40°C~+85°C.
ALL CRITICAL DIMENSIONS WITH "*"

ELECTRICAL:

VOLTAGE: 125 VOLTS AC.
CURRENT RATING : 1.5AMP.
DIELECTRIC STRENGTH: 1000 VAC RMS 50HZ OR 60HZ,1MIN.
INSULATION RESISTANCE: 500 MEGA OHMS MIN. INITIAL
AFTER 500V DC FOR 1 MINUTE.
CONTACT RESISTANCE: SINGLE TERMINAL 30 MILLIOHMS MAX.
INITIAL 50 MILLIOHMS MAX. AFTER
DURABILITY TEST.

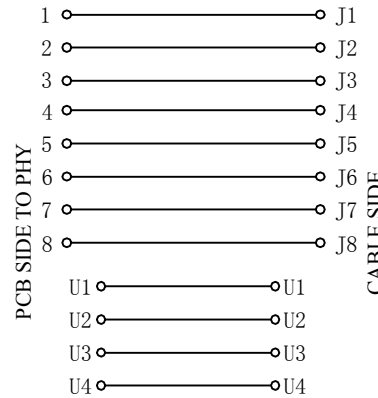

LED Specification

Standard LED Color	LED Wavelength	Foward(A)	Foward(V)
Green	568nm	20mA	1.85-2.45V
Yellow	585nm	20mA	1.7-2.2V

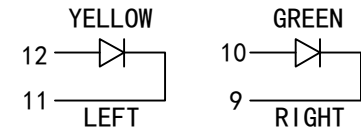

东莞市美韩电子科技有限公司
Dongguan Usakro Electronic Technology Co., Ltd
Tel : 0769-87869902 http://www.usakro.com

TITLE: RJ45+USB2.0	SIZE A4	UNITS MM[INCH]	GENERAL TOLERANCES UNLESS SPECIFIED		APPROVED BY: JP.Gong
PART NO.: DGUKRU121188AB1WDY1054	SACLE 1:1	REV A1	x±0.35	x°±3.0°	CHECKED BY: TW.Xu
REMARK:	SHEET 1/1		.x±0.30	.x°±2.0°	DESIGND BY: ZG.Hu
			.xx±0.25	.xx°±1.5°	
			.xxx±0.10	.xxx°±1.0°	