

REACH & RoHS
COMPLIANT

REV.	ECN / DESCRIPTION	BY	DATE
A0	NEW	ZG.Hu	2018.03.30
A1	ADD PART SIZE	ZG.Hu	2022.02.18

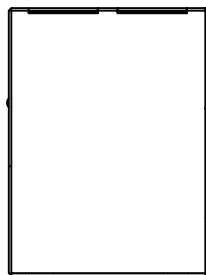

TOP VIEW

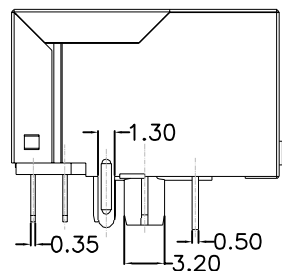

LEFT SIDE VIEW

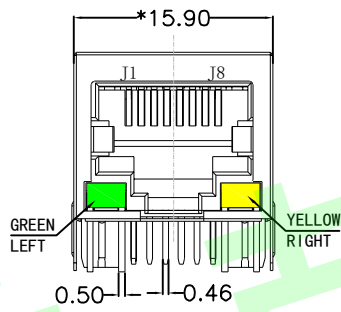

FRONT VIEW

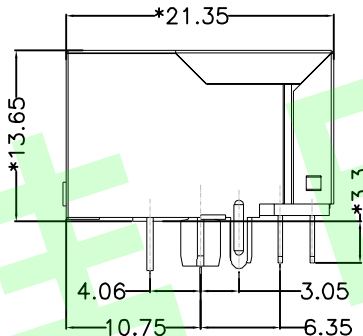

RIGHT SIDE VIEW

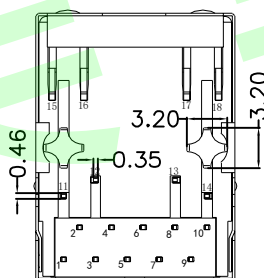

BOTTOM VIEW

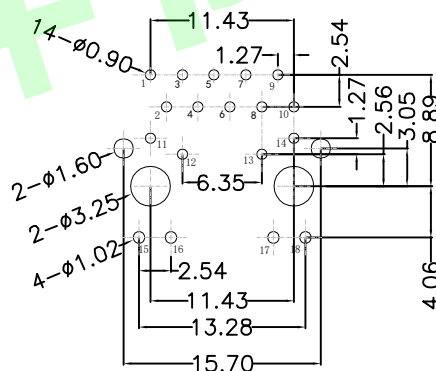

RECOMMENDED PCB LAYOUT
VIEWED FROM COMPONENT SIDE

MATERIAL:

HOUSING: PA66,UL94V-0,BLACK.
 TERMINALS BRACKET: PA66,UL94V-0,BLACK.
 SHIELD: C2680,T=0.20MM,NICKEL PLATING ON ALL AREA.
 TERMINAL: PHOSPHOR BRONZE C5191,T=0.35MM,
 6U" GOLD PLATING ON CONTACT AREA.

MECHANICAL:

DURABILITY: 750 CYCLES MIN.
 MATING FORCE: 23N MAX.
 OPERATING TEMPERATURE: 0°C~+70°C.
 STORAGE TEMPERATURE: -40°C~+85°C.
 ALL CRITICAL DIMENSIONS WITH "***"



东莞市美韩电子科技有限公司
 Dongguan Usakro Electronic Technology Co., Ltd.
 Tel : 0769-87869902 http://www.usakro.com

TITLE:
TAB-DOWN 1X1 1000BASE POE
 PART NO.:
DGUK111Q334AB2A2DP057
 REMARK:

SIZE
A4
 UNITS
MM[INCH]
 SACLE
1:1
 REV
A1
 SHEET
1/4

GENERAL TOLERANCES
UNLESS SPECIFIED
 x±0.35
 .x±0.30
 .xx±0.25
 .xxx±0.10
 x°±3.0°
 .x°±2.0°
 .xx°±1.5°
 .xxx°±1.0°

APPROVED BY:
JP.Gong
 CHECKED BY:
TW.Xu
 DESIGND BY:
ZG.Hu

REACH & RoHS
COMPLIANT

REV.	ECN / DESCRIPTION	BY	DATE
A0	NEW	ZG.Hu	2018.03.30
A1	ADD PART SIZE	ZG.Hu	2022.02.18

Suggested Panel Opening:

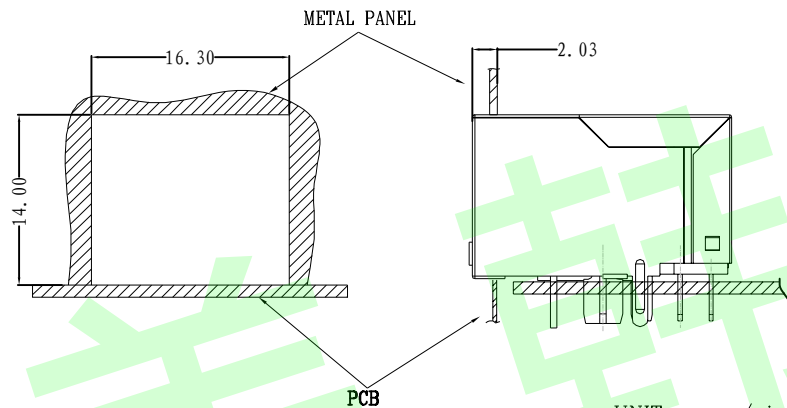

UNIT: mm / inch
Tolerances: ± 0.10 / 0.004

Keep-Out Area (Component Side View):

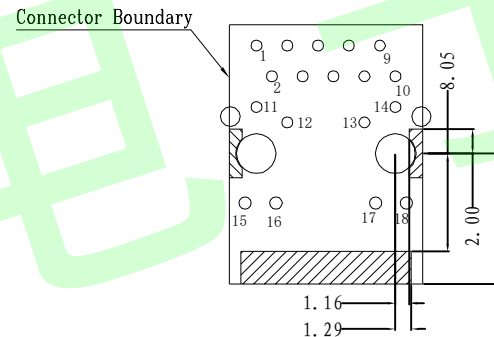

UNIT: mm / inch
Tolerances: ± 0.10 / 0.004



东莞市美韩电子科技有限公司
Dongguan Usakro Electronic Technology Co., Ltd.
Tel : 0769-87869902 <http://www.usakro.com>

TITLE: TAB-DOWN 1X1 1000BASE POE	SIZE A4	UNITS MM[INCH]	GENERAL TOLERANCES UNLESS SPECIFIED		APPROVED BY: JP.Gong
PART NO.: DGUK111Q334AB2A2DP057	SACLE 1:1	REV A1	$x \pm 0.35$	$x^\circ \pm 3.0^\circ$	CHECKED BY: TW.Xu
REMARK:	SHEET 2/4		$.x \pm 0.30$	$.x^\circ \pm 2.0^\circ$	DESIGN BY: ZG.Hu
			$.xx \pm 0.25$	$.xx^\circ \pm 1.5^\circ$	
			$.xxx \pm 0.10$	$.xxx^\circ \pm 1.0^\circ$	

REACH & RoHS
COMPLIANT

REV.	ECN / DESCRIPTION	BY	DATE
A0	NEW	ZG.Hu	2018.03.30
A1	ADD PART SIZE	ZG.Hu	2022.02.18

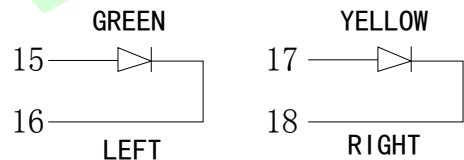
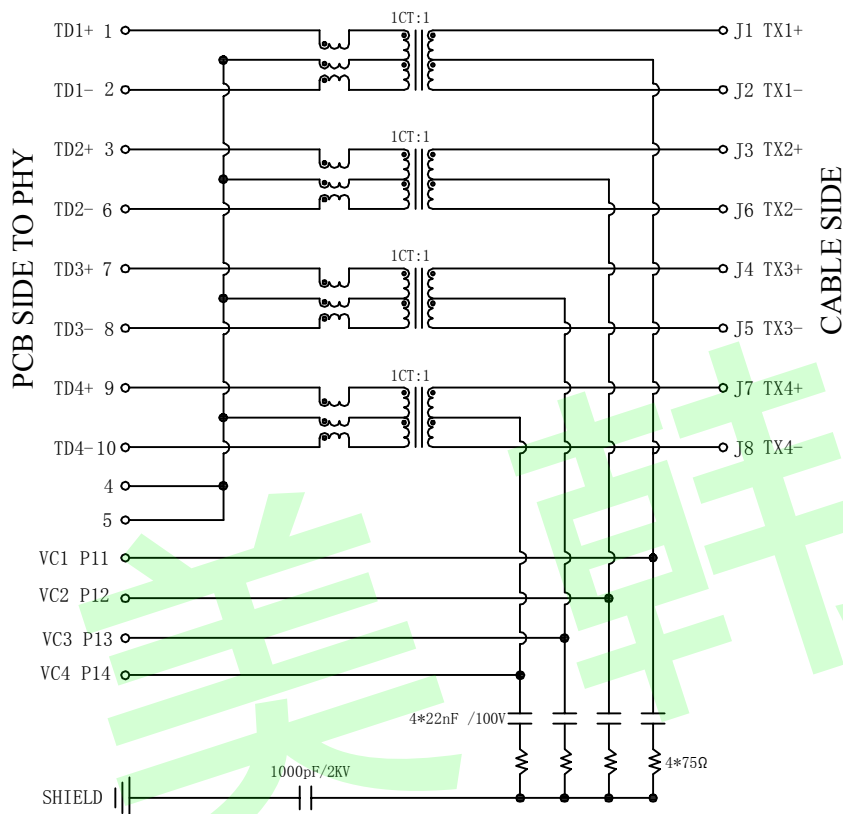

Electrical:

- Turn ratio: 1~2: J1~J2=1CT:1CT(±2%).
3~6: J3~J6=1CT:1CT(±2%).
7~8: J4~J5=1CT:1CT(±2%).
9~10: J7~J8=1CT:1CT(±2%).
- OCL: 350uH Min.at 100KHz 100mV 8mA DC.
- Insertion Loss: -1.0 dB Max 1~100MHz.
- Return loss: -18dB Min 1~30MHz;
-14dB Min 30~60MHz.
-12dB Min 60~80MHz.
-10dB Min 80~100MHz.
- Cross talk: -40dB Min 1~30MHz;
-35dB Min 30~60MHz;
-30dB Min 60~100MHz;
- CMR: -30dB Min 1~100MHz;
- Hi-Pot: 2250V DC 6S 1mA PRI TO SEC
- Single port magnetic jack POE magnetics acc.
To IEEE802.3at for PSE or PD applications.
- 100% of production tested to comply with
IEEE 802.3 isolation requirements balanced DC
line current 600mA max. 54V DC continuous.

LED Specification

Standard LED Color	LED Wavelength	Foward(A)	Foward(V)
Green	568nm	20mA	1.85-2.45V
Yellow	585nm	20mA	1.7-2.2V



东莞市美韩电子科技有限公司

Dongguan Usakro Electronic Technology Co., Ltd

Tel : 0769-87869902

http://www.usakro.com

TITLE: TAB-DOWN 1X1 1000BASE POE	SIZE A4	UNITS MM[INCH]	GENERAL TOLERANCES UNLESS SPECIFIED		APPROVED BY: JP.Gong
PART NO.: DGUK111Q334AB2A2DP057	SACLE 1:1	REV A1	x±0.35 .x±0.30	x°±3.0° .x°±2.0°	CHECKED BY: TW.Xu
REMARK:	SHEET 3/4		.xx±0.25 .xxx±0.10	.xx°±1.5° .xxx°±1.0°	DESIGND BY: ZG.Hu

REACH & RoHS
COMPLIANT

REV.	ECN / DESCRIPTION	BY	DATE
A0	NEW	ZG.Hu	2018.03.30
A1	ADD PART SIZE	ZG.Hu	2022.02.18

PROFILE OF WAVE SOLDER

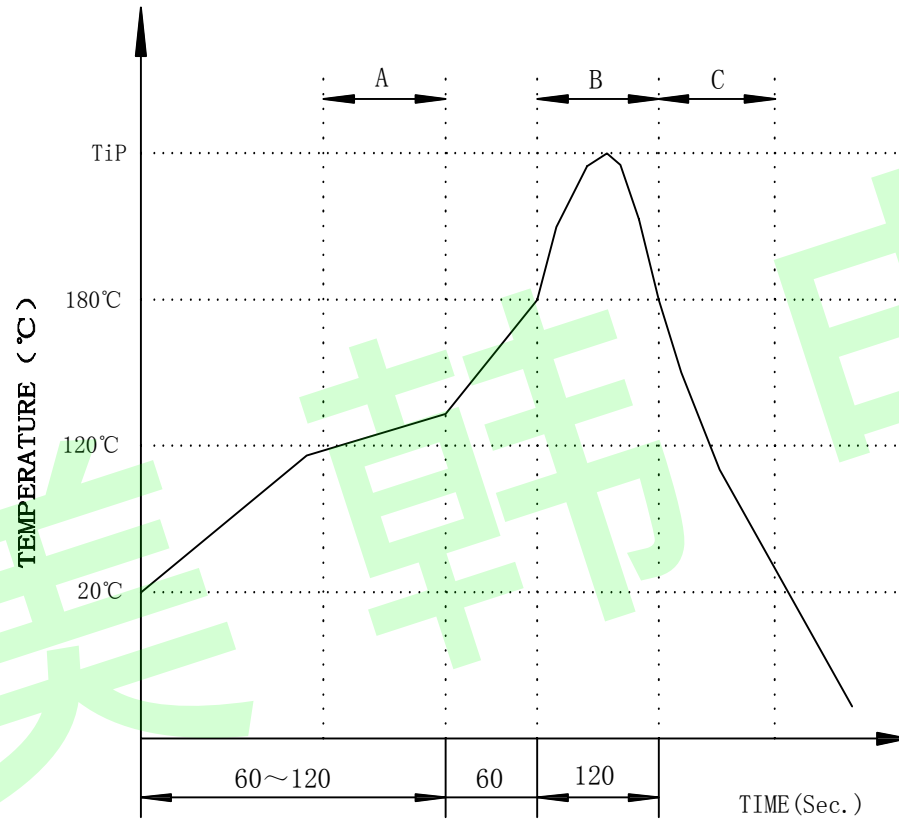

A.Preheating B.Soldering C.Gradual Cooling
 Tip temperature:260±5°C.
 Tip temperature time:5Sec Max.
 Tip melting point of Sn96.5/Ag3/Cu0.5:217°C.

Remarks: after wave soldering, the plastic positioning columns of the product which under the PCB will be slightly melted, but it won't affect its function.



TITLE: TAB-DOWN 1X1 1000BASE POE	SIZE A4	UNITS MM[INCH]	GENERAL TOLERANCES UNLESS SPECIFIED		APPROVED BY: JP.Gong
PART NO.: DGUK111Q334AB2A2DP057	SACLE 1:1	REV A1	x±0.35	x°±3.0°	CHECKED BY: TW.Xu
REMARK:	SHEET 4/4		.xx±0.25	.xx°±1.5°	DESIGND BY: ZG.Hu
			.xxx±0.10	.xxx°±1.0°	

东莞市美韩电子科技有限公司
 Dongguan Usakro Electronic Technology Co., Ltd.
 Tel : 0769-87869902 <http://www.usakro.com>