

FEATURES

- two-quadrant video multiplication
- 20 MHz 0.1 dB video & control channel bandwidth
- one external frequency compensation adjustment
- ultra low differential gain & differential phase
- convenient 8 pin package

APPLICATIONS

- Multimedia Graphics Overlay
- Production switchers
- Linear Keyers

PIN CONNECTIONS

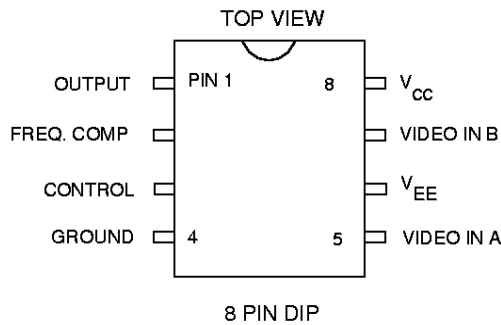

ORDERING INFORMATION

Part Number	Package Type	Temperature Range
GT4123 - CDA	8 pin PDIP	0° to 70°C
GT4123 - CKA	8 pin SOIC	0° to 70°C
GT4123ACDA	8 pin PDIP	0° to 70°C
GT4123ACKA	8 pin SOIC	0° to 70°C

DESCRIPTION

The GT4123 and GT4123A are monolithic dual-channel video multipliers for use in a wide range of applications including broadcast and multimedia.

Featuring two wideband video inputs and a single control input, they achieve high quality video mixing of the two video input signals to a single output by implementing the function:

$$V_O = [(V_C \cdot V_A) + (1 - V_C) \cdot V_B]$$

where V_C is the control input voltage, which may be varied continuously over the range 0 to 1V with respect to the ground pin, and V_A and V_B are the video input signals.

The GT4123 operates with typical power supply voltages of ± 10 volts and draws 15 mA of current. The GT4123A typically operates from +12 and -5 volt supplies. Both are available in 8 pin PDIP and 8 pin SOIC.

An Application Note entitled "Using the GT4123 and GT4123A Video Mixer ICs" (Document No. 520 - 61) is available from Gennum Corporation.

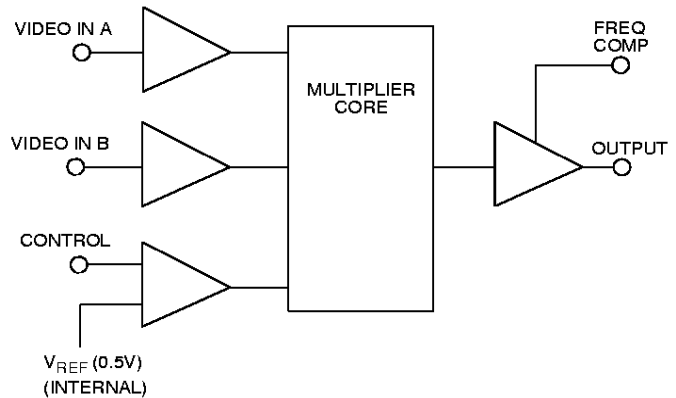

FUNCTIONAL BLOCK DIAGRAM

CAUTION
ELECTROSTATIC SENSITIVE DEVICES
DO NOT OPEN PACKAGES OR HANDLE EXCEPT AT A STATIC-FREE WORKSTATION

ABSOLUTE MAXIMUM RATINGS

PARAMETER	VALUE
Supply Voltage (V_S)	± 13.5 V
Operating Temperature Range	$0^\circ\text{C} \leq T_A \leq 70^\circ\text{C}$
Storage Temperature Range	$-65^\circ\text{C} \leq T_S \leq 150^\circ\text{C}$
Lead Temperature (Soldering, 10 Sec)	260°C
Video Input Voltage (V_A, V_B) to ground	± 5 V
Control Input Voltage (V_C) to ground	± 5 V
Video Input Differential Voltage ($V_A - V_B$)	± 5 V

ELECTRICAL CHARACTERISTICS GT4123 $V_S = \pm 10\text{V}$, $T_A = 0^\circ\text{C}$ to 70°C , $R_L = 10\text{k}\Omega$ unless otherwise shown.

	PARAMETER	SYMBOL	CONDITIONS	MIN	TYP	MAX	UNITS
POWER SUPPLIES	Supply Voltage	V_S	Operating Range	± 9	± 10	± 12	V
	+ Supply Current	I+		-	15	19.5	mA
	- Supply Current	I-		-	13	17.0	mA
SIGNAL CHANNEL	Common Mode Input Signal	$V_{IN\text{ CM}}$		-	-	5	V
	Bandwidth	$BW_{0.1}$	at ± 0.1 dB $V_{IN} = 150$ mVp-p	20	25	-	MHz
	Bandwidth	BW_3	at -3 dB $V_{IN} = 1$ Vp-p	-	80	-	MHz
	Frequency Response		DC - 10 MHz	-	± 0.05	-	dB
	Differential Gain	∂g	$V_{IN} = 40$ IRE at 3.58 MHz	-	0.01	0.05	%
	Differential Phase	∂p	$V_{IN} = 40$ IRE at 3.58 MHz	-	0.01	0.05	degrees
	Signal to Noise	S/N	$V_{SIG} = 1$ V, $BW = 5$ MHz	64	70	-	dB
	Gain	A_{VL}	100 kHz ($\beta = 100\%$)	-0.02	-0.005	-	dB
	Delay	$t_{d\text{ SIG}}$		-	4	10	ns
	Off Isolation & Crosstalk	$V_{A\text{ or }B}/V_O$	$f_{SIG} = 5$ MHz (see note 1)	70	75	-	dB
		$V_C/V_{A\text{ or }B}$	$f_{SIG} = 5$ MHz (see note 2)	80	85	-	dB
	Input Resistance	R_{IN}	$f = 1$ MHz	150	-	-	k Ω
	Input Capacitance	C_{IN}		-	2.0	-	pF
Output Resistance	R_{OUT}	$f = 1$ MHz (see Figure 9)	-	-	0.1	Ω	
Output Capacitance	C_{OUT}		-	2.0	-	pF	
CONTROL CHANNEL	Bandwidth	$BW_{0.1}$	at ± 0.1 dB $V_{IN} = 150$ mVp-p	20	25	-	MHz
	Bandwidth	BW_3	at -3 dB $V_{IN} = 1$ Vp-p	-	80	-	MHz
	Delay	$t_{D\text{ CONT}}$		-	4	10	ns
	Linearity		10% to 90% range	-	1	-	%
	Control Breakthrough		$V_C = 0$ to 1 V $f_C = 1$ to 10 MHz	-	-	-35	dB
	Crossfade Balance		$V_C = 0$ to 1 V $f_C = 3.58$ MHz	-	5	10	mVp-p
	Control Range	V_C	(see Figure 10)	0	-	+1	V

- NOTE:**
- V_A or $B = +1$ Vp-p output taken from OUTPUT
 - $V_C = +1$ Vp-p output taken from V_A or V_B

ELECTRICAL CHARACTERISTICS GT4123A $V_S = \pm 12V, -5V, T_A = 0^\circ C \text{ to } 70^\circ C, R_L = 10k\Omega$ unless otherwise shown.

	PARAMETER	SYMBOL	CONDITIONS	MIN	TYP	MAX	UNITS
POWER SUPPLIES	Supply Voltage	V_S	Operating Range	+9 -3	+12 -5	± 12	V
	+ Supply Current	I+	.	-	15	19.5	mA
	- Supply Current	I-		-	13	17.0	mA
SIGNAL CHANNEL	Common Mode Input Signal	V_{INCM}		-	-	5	V
	Bandwidth	$BW_{0.1}$	at ± 0.1 dB $V_{IN} = 150$ mVp-p	20	25	-	MHz
	Bandwidth	BW_3	at -3 dB $V_{IN} = 1$ Vp-p	-	80	-	MHz
	Frequency Response		DC -10 MHz	-	± 0.05	-	dB
	Differential Gain	∂g	$V_{IN} = 40$ IRE at 3.58 MHz	-	0.02	0.05	%
	Differential Phase	∂p	$V_{IN} = 40$ IRE at 3.58 MHz	-	0.02	0.05	degrees
	Signal to Noise	S/N	$V_{SIG} = 1$ V, $BW = 5$ MHz	64	70	-	dB
	Gain	A_{VL}	100 kHz ($\beta = 100\%$)	-0.02	-0.005	-	dB
	Delay	$t_{d SIG}$		-	4	10	ns
	Off Isolation & Crosstalk	$V_{A \text{ or } B}/V_O$	$f_{SIG} = 5$ MHz (see note 1)	70	75	-	dB
		$V_C/V_{A \text{ or } B}$	$f_{SIG} = 5$ MHz (see note 2)	80	85	-	dB
	Input Resistance	R_{IN}	$f = 1$ MHz	150	-	-	k Ω
	Input Capacitance	C_{IN}		-	2.0	-	pF
	Output Resistance	R_{OUT}	$f = 1$ MHz (see Figure 9)	-	-	0.1	Ω
Output Capacitance	C_{OUT}		-	2.0	-	pF	
CONTROL CHANNEL	Bandwidth	$BW_{0.1}$	at ± 0.1 dB $V_{IN} = 150$ mVp-p	20	25	-	MHz
	Bandwidth	BW_3	at -3 dB $V_{IN} = 1$ Vp-p	-	80	-	MHz
	Delay	$t_{D CONT}$		-	4	10	ns
	Linearity		10% to 90% range	-	1	-	%
	Control Breakthrough		$V_C = 0$ to 1 V $f_C = 1$ to 10 MHz	-	-	-35	dB
	Crossfade Balance		$V_C = 0$ to 1 V $f_C = 3.58$ MHz	-	5	10	mVp-p
	Control Range	V_C	(see Figure 10)	0	-	+1	V

NOTE: 1. $V_{A \text{ or } B} = +1$ Vp-p output taken from OUTPUT
 2. $V_C = +1$ Vp-p output taken from V_A or V_B

DETAILED DESCRIPTION

The GT4123 and GT4123A are the first dedicated single device, two input video mixer ICs available to the professional video and multimedia markets.

The internal topology of the devices is shown in Figure 1.

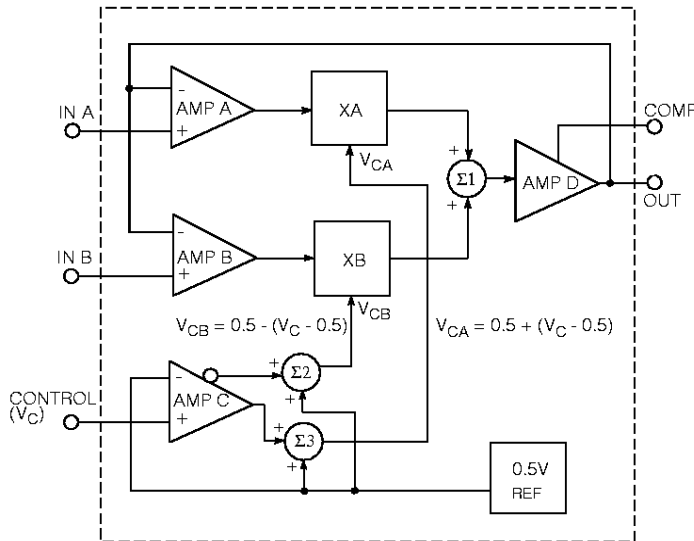

Fig. 1 Functional Block Diagram of the GT4123 and GT4123A

Each input signal is applied to a conventional differential amplifier (AMP A and AMP B). From the amplifiers, the signals are applied to analog multiplier circuits (XA and XB) whose outputs are the product of the input signals and internally generated controlling voltages V_{CA} and V_{CB} .

These voltages are derived from a unity gain differential amplifier (AMP C) whose outputs (true and invert) are the difference between an externally applied CONTROL voltage (V_C) and an internal 0.5 volt reference voltage. In addition, the internal DC offset of 0.5 volts is applied to the controlling voltage summing circuits $\Sigma 2$ and $\Sigma 3$.

Therefore,

$$V_{CA} = 0.5V + (V_C - 0.5V) \text{ and}$$

$$V_{CB} = 0.5V - (V_C - 0.5V)$$

When the CONTROL input (V_C) equals 0.5 volts, V_{CA} and $V_{CB} = 0.5$ volts and exactly 50% of each input signal passes to the output of the multiplier stages.

When V_C is less than 0.5 volts, V_{CA} reduces and V_{CB} increases in proportion so that less of the Channel A signal and more of the Channel B signal is transferred. Similarly, when V_C is greater than 0.5 volts, the opposite occurs.

The SPAN or control range is internally set so that a CONTROL voltage of 0 volts completely cuts off Channel A and fully turns on Channel B. Similarly, a CONTROL voltage of 1 volt will fully turn on Channel A and completely turn Channel B off.

Figure 10 shows the CONTROL transfer characteristics of the GT4123 and GT4123A.

There is a small 'dead band' at either extreme of the CONTROL input. The amount of 'dead band' is about 100 mV and is shown in Figure 10. The CONTROL input can be preceded by an operational amplifier so biased as to overcome this 'dead band' as well as level shift the control signal so that other than 0 to 1 volt ranges can be used. The bandwidth of the CONTROL input is sufficient to allow very fast keying and is in the order of 20 MHz at -0.1 dB.

The linear portion of the transfer characteristic has a linearity of 1% or better.

The outputs from the multipliers are applied to an analog summing circuit ($\Sigma 1$) whose output feeds a wideband amplifier (Amp D) and presents the mixed signals to the outside world. The inverting inputs of each input amplifier are directly connected to the output.

In this manner the closed loop gain is nearly unity providing wideband, stable operation. Because the devices have only 8 pins and require virtually no external parts in order to function, they lend themselves to high density, multi-functional PC board layouts. Several devices can be used in parallel applications such as R-G-B mixers and four-layer keyers where close control law tracking is essential.

The only difference between the GT4123 and the GT4123A is the fact that the latter device can operate with non-equal power supplies. The negative supply can be as low as -3 volts unlike the GT4123 which can only operate down to ± 9 volt supplies.

GT4123 / GT4123A TEST CIRCUITS

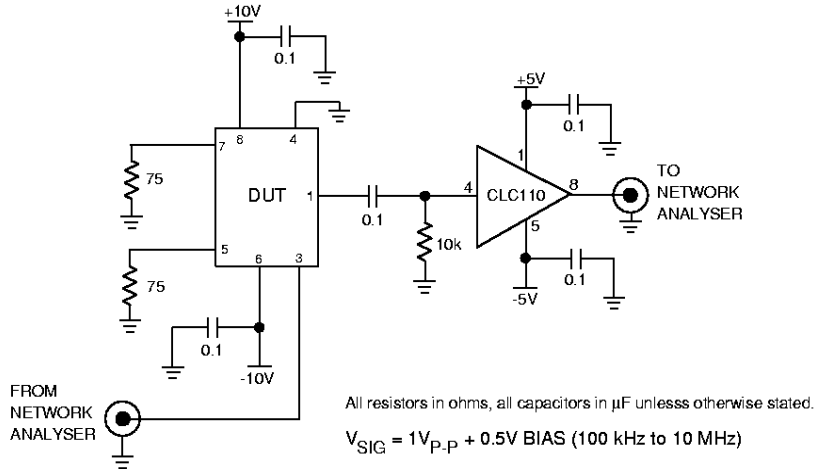

Fig. 2 Crossfade Balance

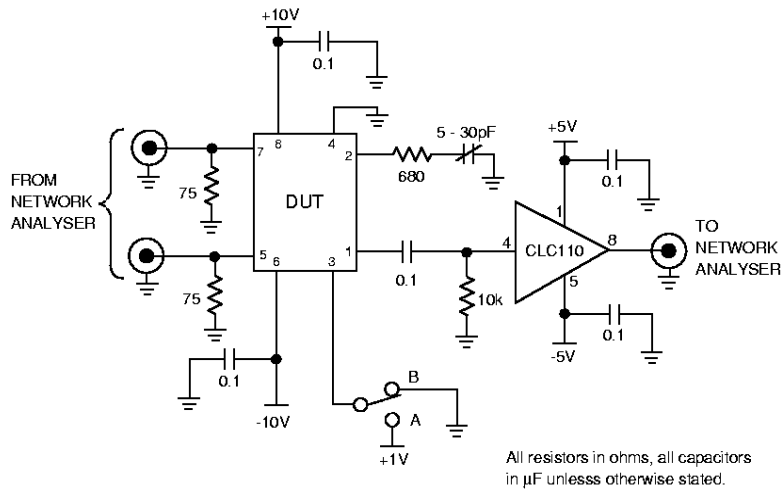

Fig. 3 Frequency Response, Crosstalk & Differential Gain & Phase

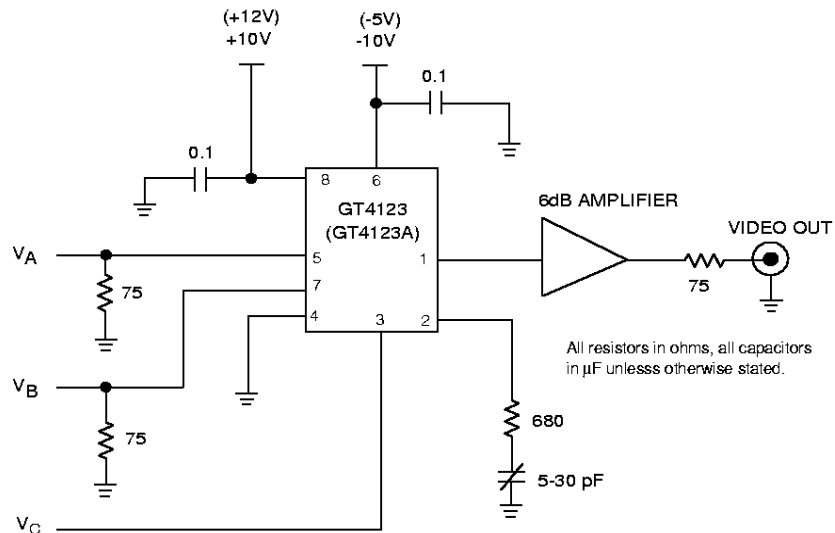

Fig. 4 Typical Application Circuit

TYPICAL PERFORMANCE CURVES FOR GT4123 / GT4123A

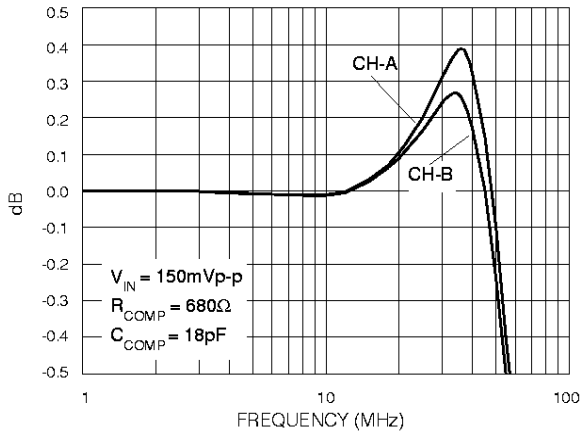

Fig. 5 Frequency Response

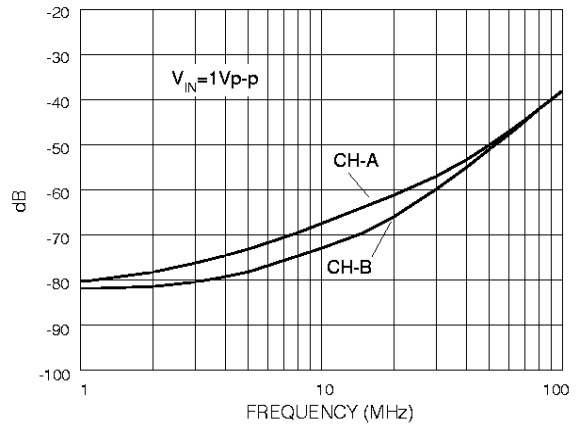

Fig. 6 Crosstalk vs Frequency

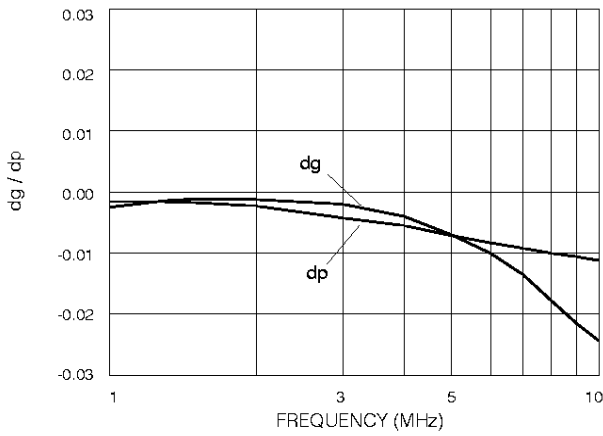

Fig. 7 Differential Gain & Phase vs Frequency

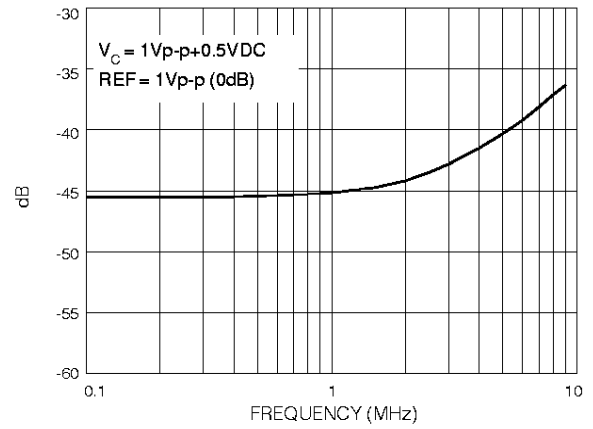

Fig. 8 Crossfade Balance vs Frequency

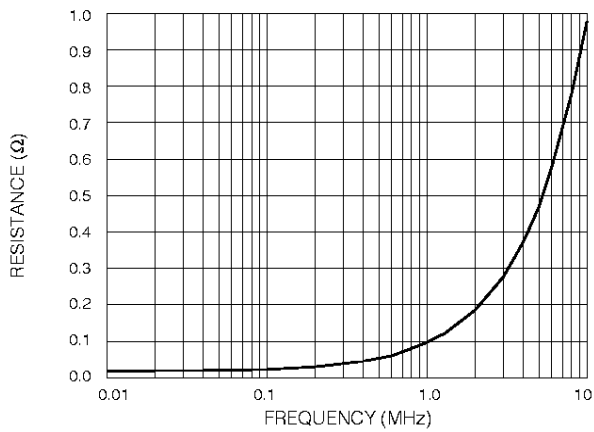

Fig. 9 Output Resistance vs Frequency

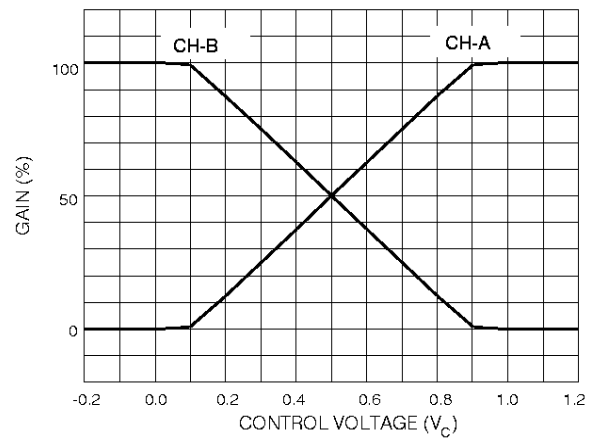

Fig. 10 Control Characteristics

Revision Notes: Detailed Description added.

**DOCUMENT
IDENTIFICATION**

PRODUCT PROPOSAL

This data has been compiled for market investigation purposes only, and does not constitute an offer for sale.

ADVANCE INFORMATION NOTE

This product is in a development phase and specifications are subject to change without notice. Gennum reserves the right to remove the product at any time. Listing the product does not constitute an offer for sale.

PRELIMINARY DATA SHEET

The product is in a preproduction phase and specifications are subject to change without notice.

DATA SHEET

The product is in production. Gennum reserves the right to make changes at any time to improve reliability, function or design, in order to provide the best product possible.