

1

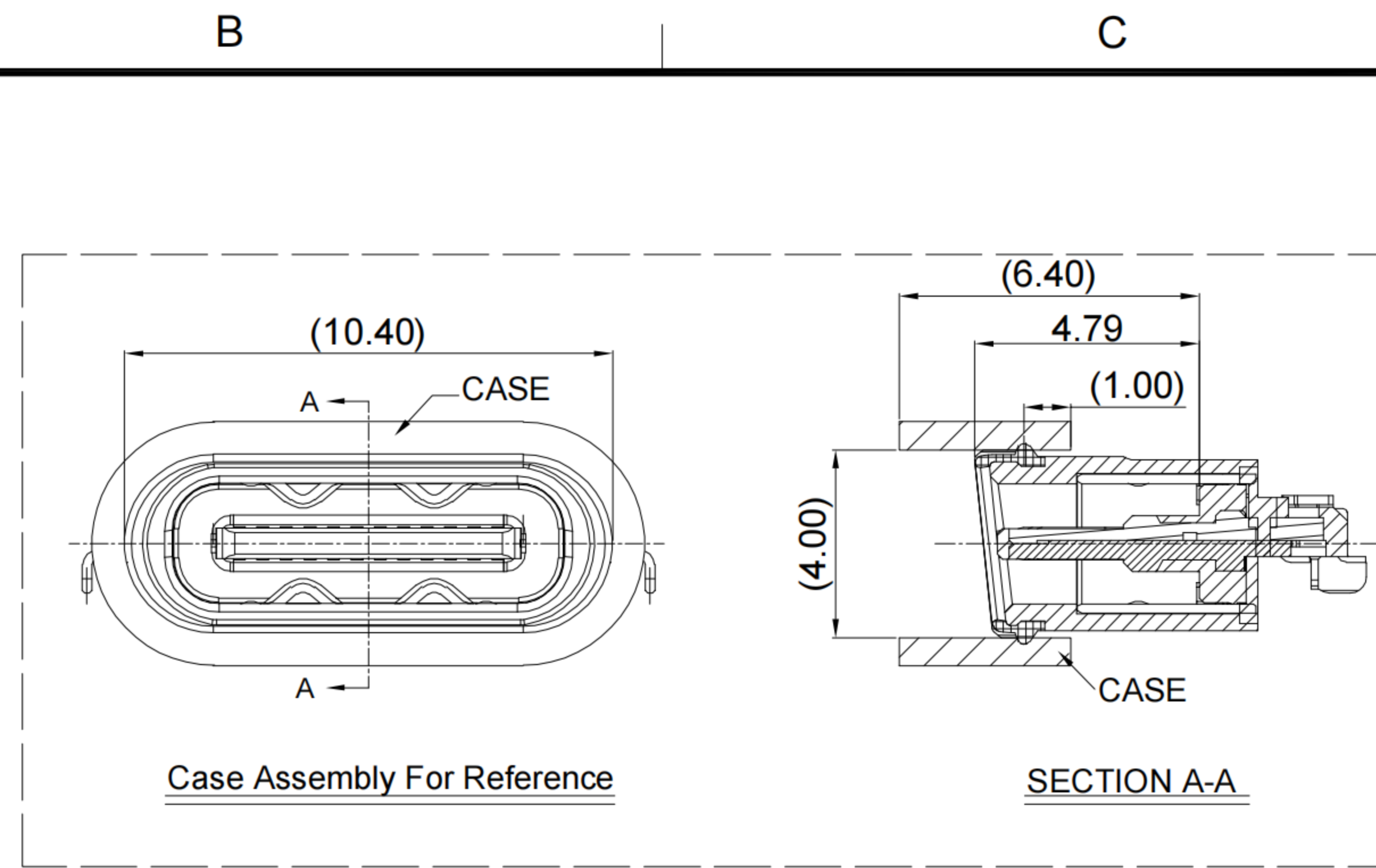

2

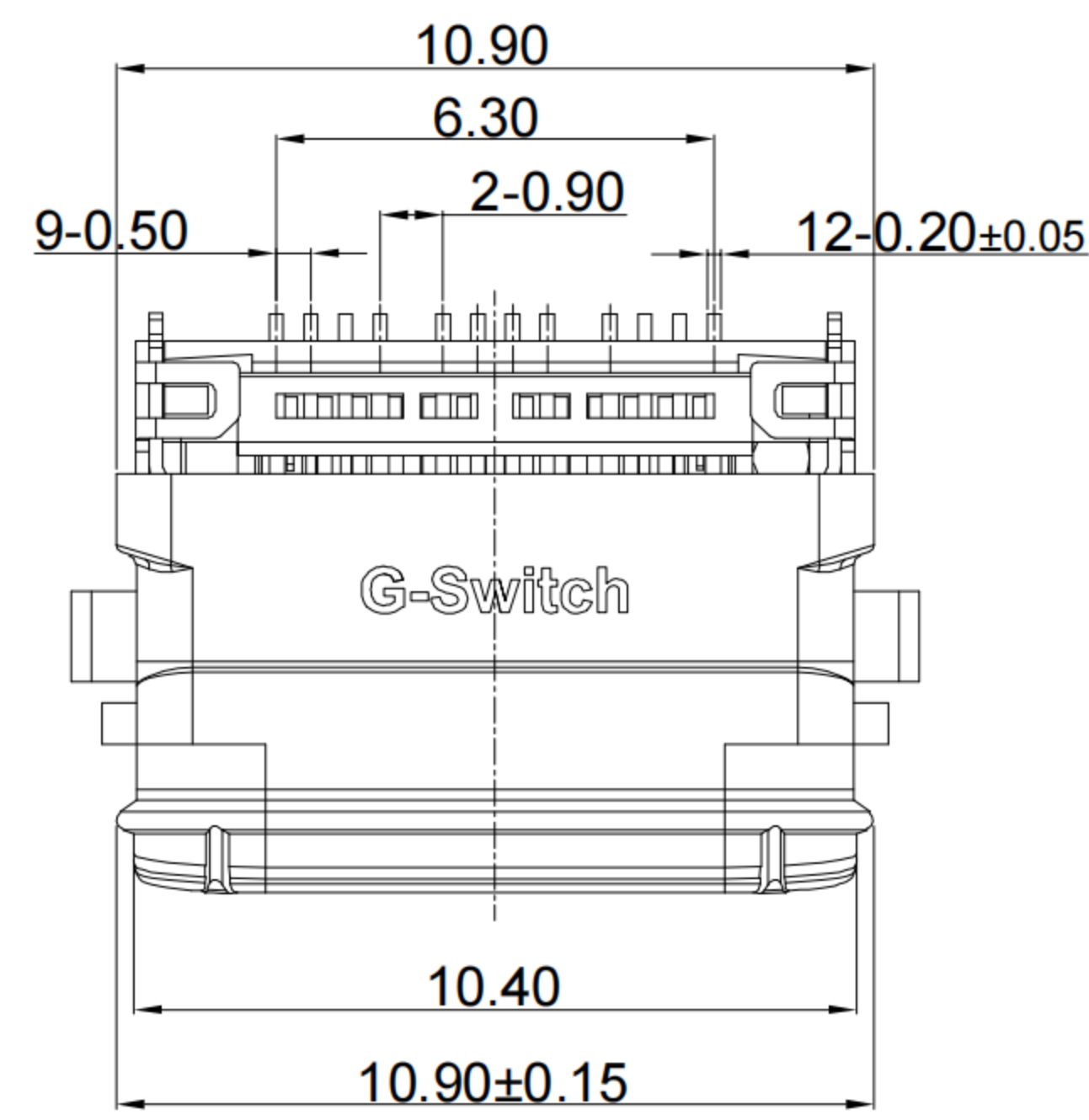
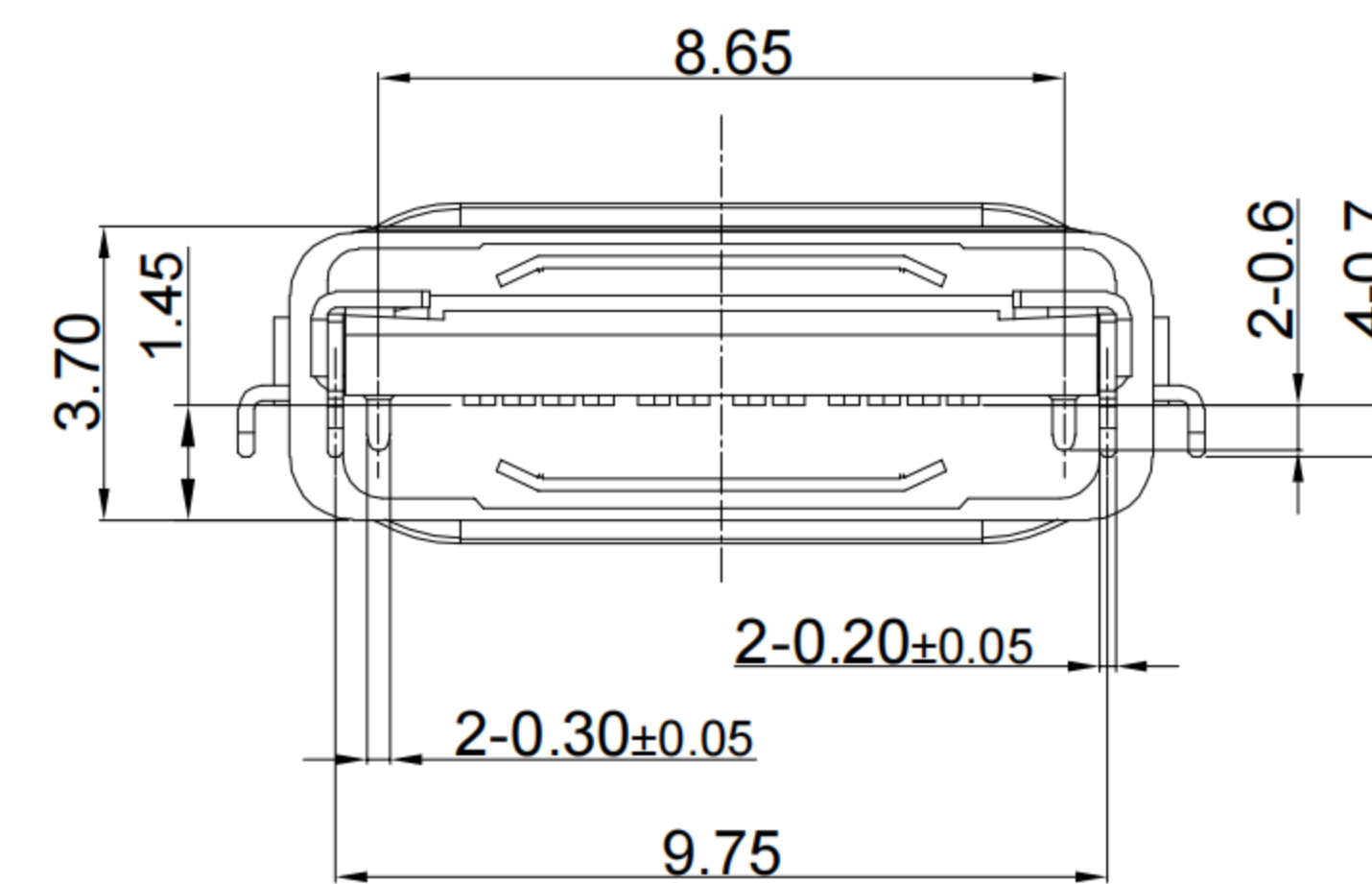
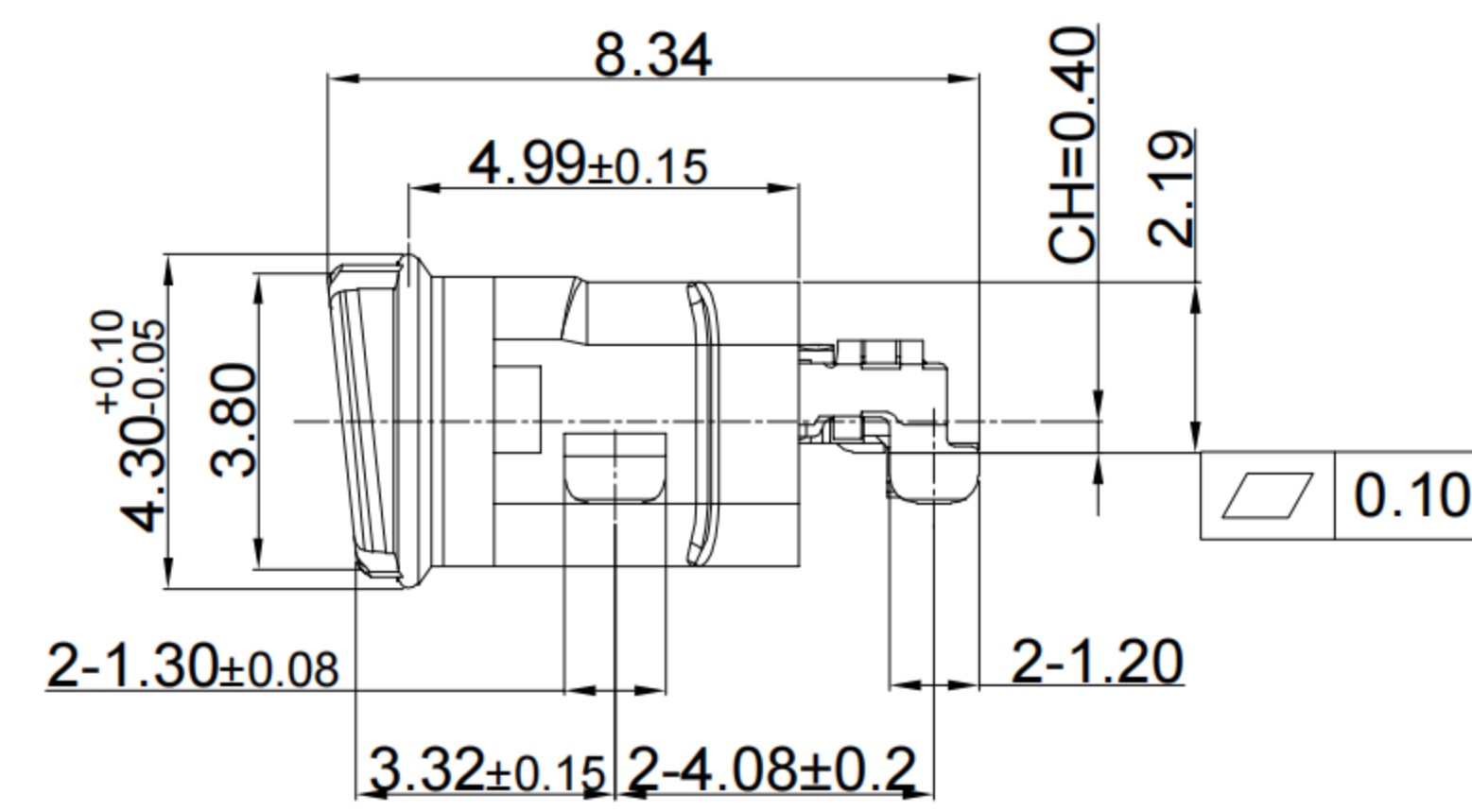
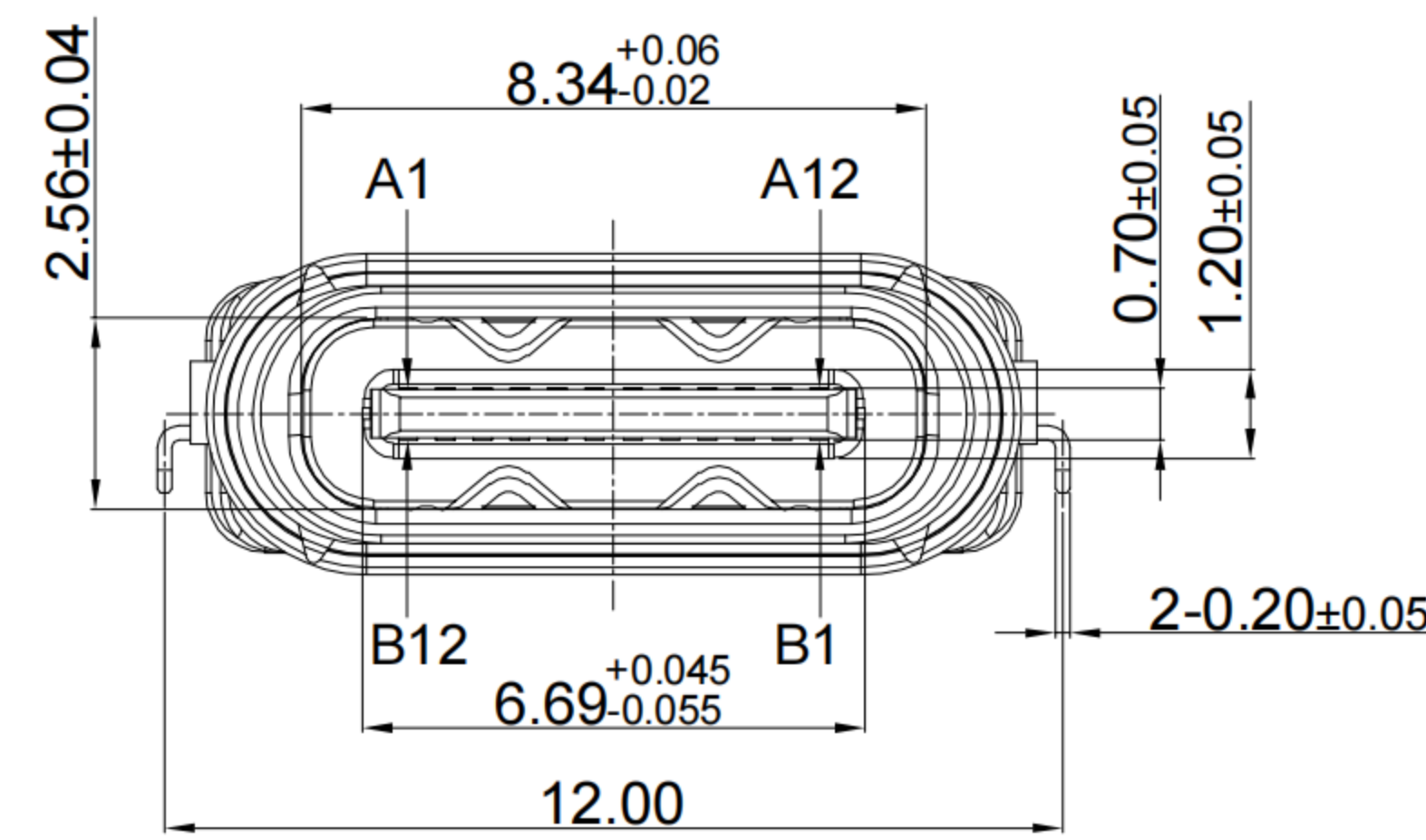

G-Switch USB-C Specification:

1. Current rated: 5A on Vbus/1.25A on Vconn/0.25A on other
2. Voltage rating: 24V AC
3. Contact Resistance: 40mΩ Max
4. Insulation Resistance: 100MΩ Min
5. Operating temperature: -40 °C ~ +85 °C
6. Mating force: 5N~20N
7. Unmating force: 8N~20N
8. Durability Cycle: 10,000 Cycles
9. Data transmission rate up to 10Gbps
10. Waterproof Grade: IP-X7.

3

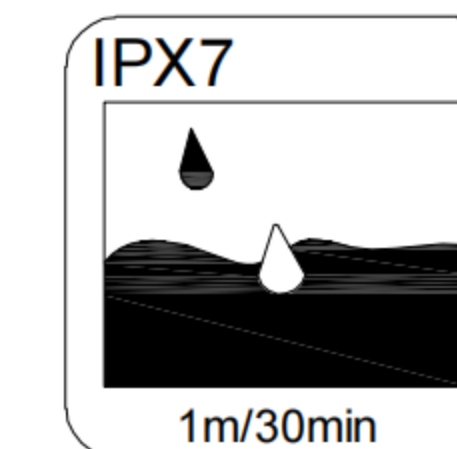
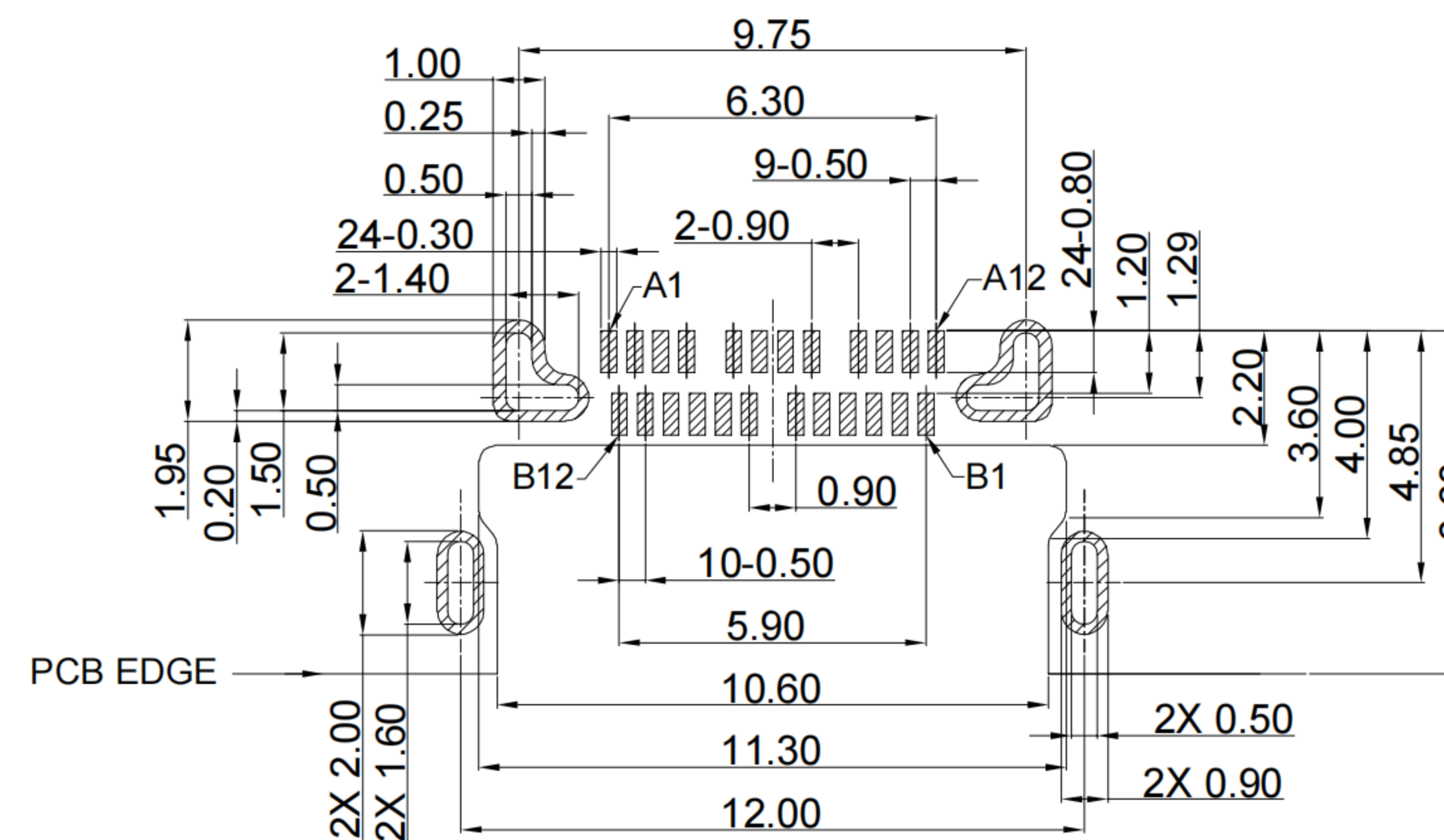
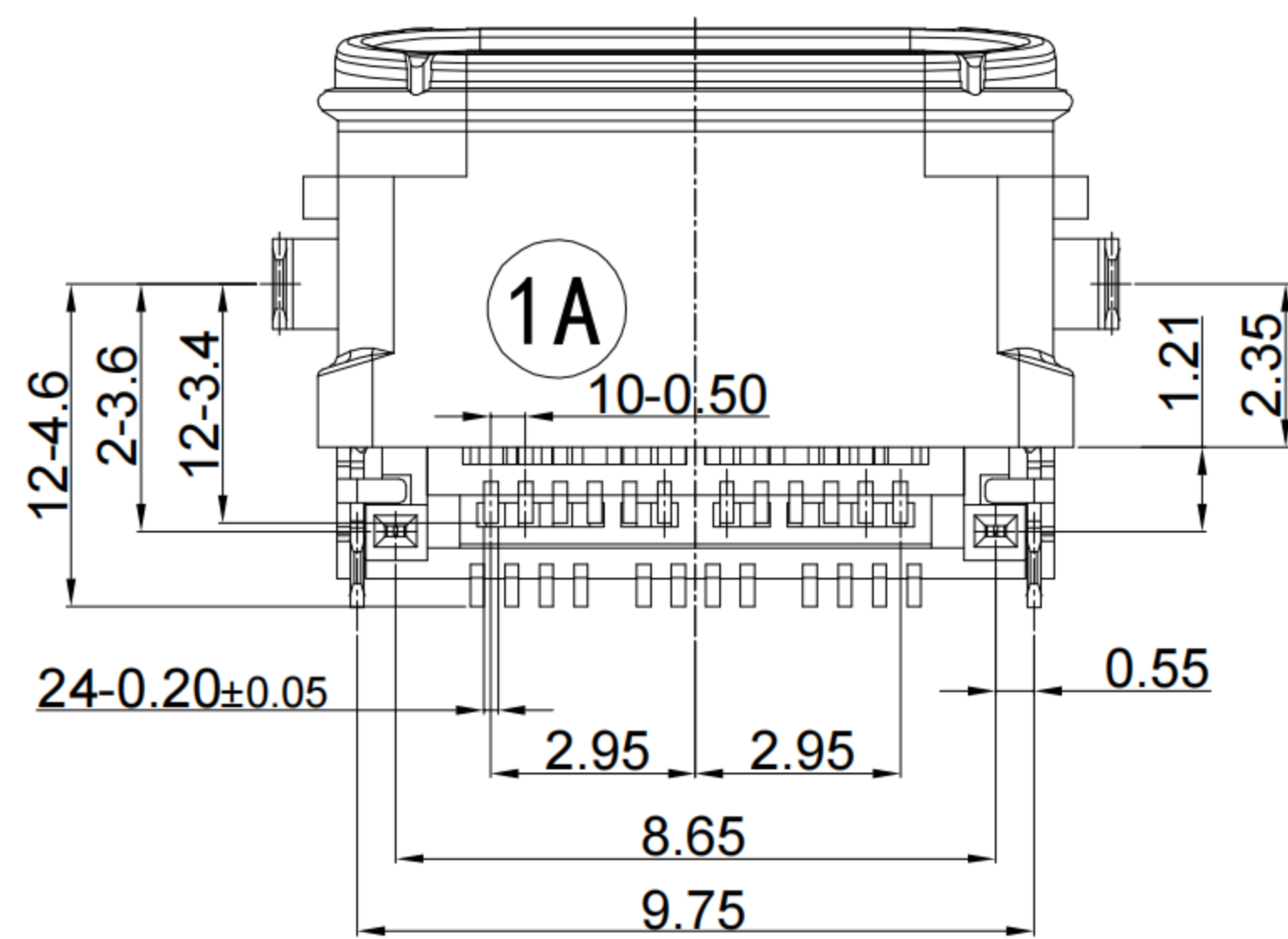

A1	A2	A3	A4	A5	A6	A7	A8	A9	A10	A11	A12
GND	TX1+	TX1-	VBUS	CC1	D+	D-	SBU1	VBUS	RX2-	RX2+	GND
First	Second	Second	First	Second	Second	Second	Second	First	Second	Second	First
B12	B11	B10	B9	B8	B7	B6	B5	B4	B3	B2	B1
GND	RX1+	RX1-	VBUS	SBU2	D-	D+	CC2	VBUS	TX2-	TX2+	GND
First	Second	Second	First	Second	Second	Second	Second	First	Second	Second	First

4

1	COVER SHELL	STAINLESS STEEL	NI PLATED
2	SHELL	STAINLESS STEEL	NI PLATED
3	GND PLATE	STAINLESS STEEL	---
4	MID PLATE	STAINLESS STEEL	NI PLATED
5	HOUSING	HIGH TEMPERATURE PLASTIC	Black UL 94 V-0
6	TERMINALS	COPPER ALLOY	Au PLATING ON CONTACT AREA
7	WATERPROOF RING	SILICA GEL	Black
NO.	PARTS	MATERIAL	REMARKS

RECOMMENDED PCB LAYOUT
TOLERANCE: ±0.05



SCALE: 1:1 UNIT: mm
SIZE: A4

Unless otherwise
General Tolerance:
X. ±0.25
X.x ±0.20
X.xx ±0.15
X.xxx ±0.10
X° ±5°

Title: Horizontal Type-c 24P Female Sink 1.45 CH=0.4 L=8.34mm

Molde Code: GT-USB-7026

DRAWN	CHECKED	APPROVED	DATE
Xia	Chen	Chen	2023.02.01



REV: A0 SHEET: 1/1

5