

70dB PSRR, Low Noise, Fast Response 300mA LDO in DFN1x1 and SOT23-5

DESCRIPTION

ETA5053 is a fixed output, low-dropout (LDO) low-power linear voltage regulator features high power-supply rejection ratio (PSRR), ultralow-noise, fast start-up, and excellent line and load transient responses. Its PSRR can be as high as 70dB with quiescent current is about 35uA. Therefore, ETA5053 is an ideal power supply for noise-sensitive applications such as RF transmissions, cellphones, CMOS sensors and audios etc.

ETA5053 is available in DFN1x1 and SOT23-5.

FEATURES

- ◆ High PSRR, 70dB
- ◆ 300mA Output Current
- ◆ Stable with a Wide Range of Ceramic Capacitor
- ◆ Excellent Load and Line Transient Response
- ◆ 0.24V Dropout Voltage for 200mA at Vout=3.3V
- ◆ 35uA Iq

APPLICATIONS

- ◆ Cellphone
- ◆ Security Camera
- ◆ Set-Top Box

TYPICAL APPLICATION

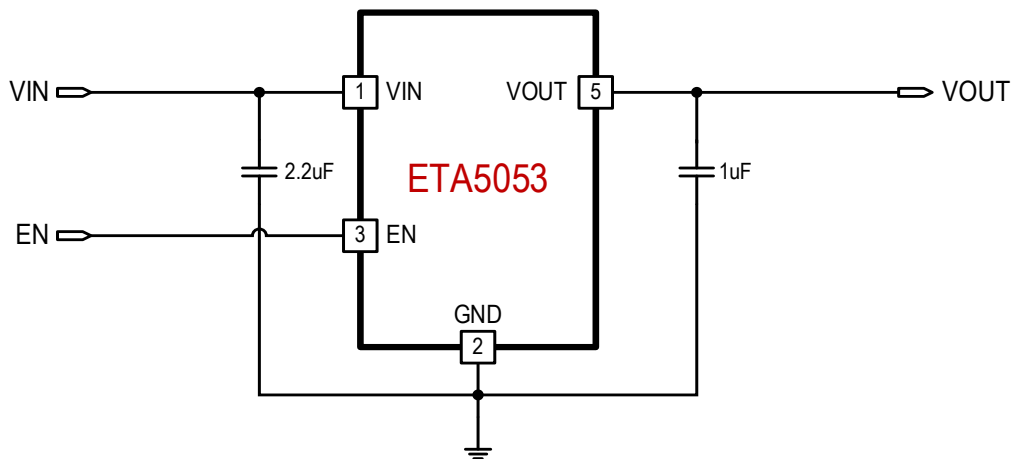

ORDERING

INFORMATION

PART No.	PACKAGE	TOP MARK	Pcs/Reel
ETA5053VXXXOS2F	SOT23-5	PPYW	3000
ETA5053VXXXQF1E	DFN1x1-4	PP YW	10000
ETA5053VXXXQD1E	DFN1x1-4	PP YW	10000
XXX: voltage code e.g. 120 =1.2V Q=N: no discharge; Q=D: discharge; O=W: fast discharge		PP: product code (PP1 for fast discharge) YW: date code	

PIN CONFIGURATION

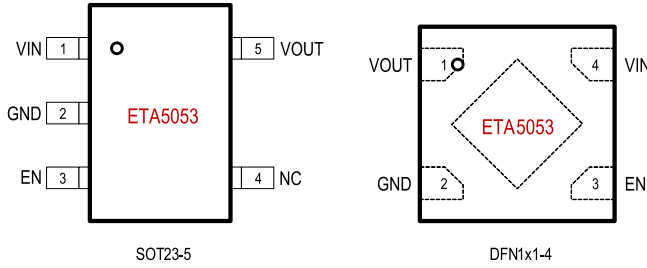

ABSOLUTE MAXIMUM RATINGS

(Note: Exceeding these limits may damage the device. Exposure to absolute maximum rating conditions for long periods may affect device reliability.)

- VIN, EN, VOUT Voltage.....-0.3V to 6V
- Operating Temperature Range.....-40°C to 85°C
- Storage Temperature Range.....-55°C to 150°C
- Thermal Resistance θ_{JA} θ_{JC}
- SOT23-5.....180.....90.....°C/W
- DFN1x1-4.....120.....60.....°C/W
- Lead Temperature (Soldering 10sec)..260°C
- ESD HBM (Human Body Mode)2KV
- ESD CDM (Charged Device Mode)1KV

ELECTRICAL CHARACTERISTICS

(VIN = VOUT+1V, CIN=2.2µF, COUT=1µF, unless otherwise specified. Typical values are at TA = 25°C.)

PARAMETER	CONDITIONS	MIN	TYP	MAX	UNIT
Input Voltage Range ⁽¹⁾		1.6		6.0	V
Ground Current	No Load		35	60	µA
Shutdown Current	V _{EN} = 0V, 1.8V ≤ VIN ≤ 6V		0	1	µA
Dropout Voltage	I _{OUT} = 300mA, V _{OUT} =1.05V		1050	1200	mV
	I _{OUT} = 300mA, V _{OUT} =1.2V		850	1000	mV
	I _{OUT} = 300mA, V _{OUT} =1.5V		720	850	mV
	I _{OUT} = 300mA, V _{OUT} =1.8V		550	700	mV
	I _{OUT} = 300mA, V _{OUT} =3.0V		350	500	mV
	I _{OUT} = 300mA, V _{OUT} =3.3V		330	450	mV
Continuous Output Current				300	mA
Output Current Limit	V _{OUT} = 95%	350	500		mA
Output Foldback Current Limit	V _{OUT} = 0V		250		mA
Line Regulation	V _{OUT} + 1V ≤ VIN ≤ 6V			0.12	%/V
Load Regulation	0µA ≤ I _{OUT} ≤ 200 mA		20		mV
Output Voltage Range	Available in 50mV steps	0.8		3.95	V
Vout Voltage accuracy	I _{OUT} =30mA	-2		+2	%
Power Supply Rejection Ratio	Freq = 100Hz, I _{OUT} = 30mA		73		dB
	Freq = 1kHz, I _{OUT} = 30mA		70		
Start-up time			50		µs
EN pin input Logic Low	1.8V ≤ VIN ≤ 6V			0.4	V
EN pin input Logic High	1.8V ≤ VIN ≤ 6V	1.4			V
Input current at EN pin	V _{EN} =3V		1		µA
Thermal Shutdown	Rising, Hysteresis =30°C		150		°C

(1): Minimum VIN is 1.6V or VOUT + V_{DROPOUT}, whichever is greater.

PIN DESCRIPTION

SOT23-5 PIN #	DFN1x1-4 PIN#	NAME	DESCRIPTION
1	4	VIN	Input Supply Pin
2	2	GND	Ground Pin
3	3	EN	Enable Pin. Drive it high to enable IC, drive it low to disable. EN can be connected to IN if not used.
4		NC	Not Connected
5	1	VOOUT	Output of regulator

TYPICAL CHARACTERISTICS

(Typical values are at $T_A = 25^\circ\text{C}$ unless otherwise specified.)

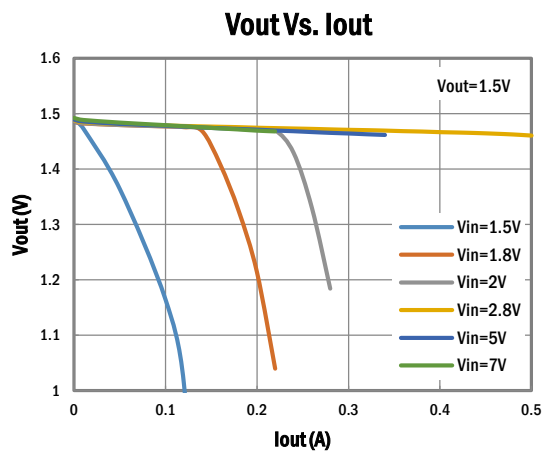
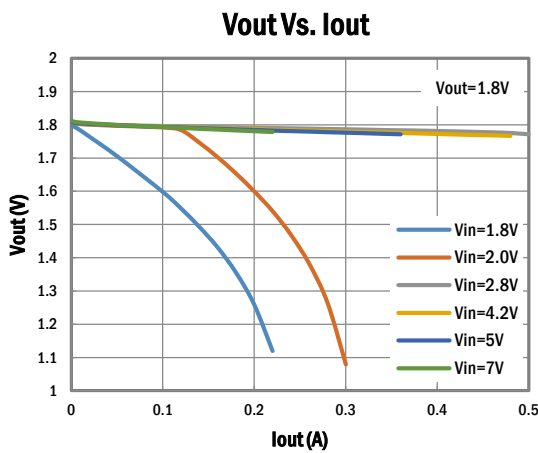
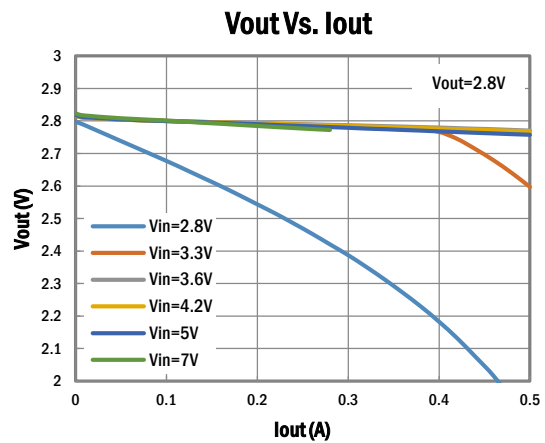
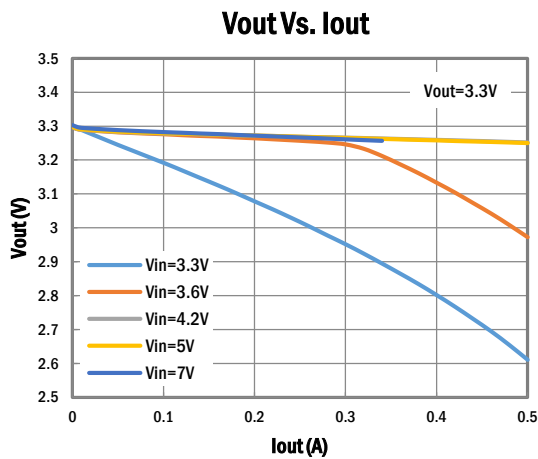

TYPICAL CHARACTERISTICS Cont'd

(Typical values are at $T_A = 25^\circ\text{C}$ unless otherwise specified.)

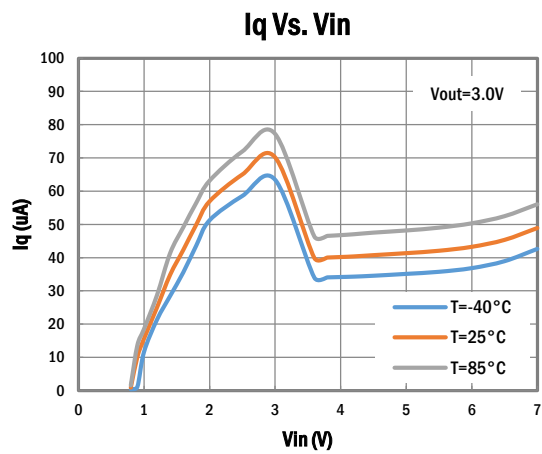
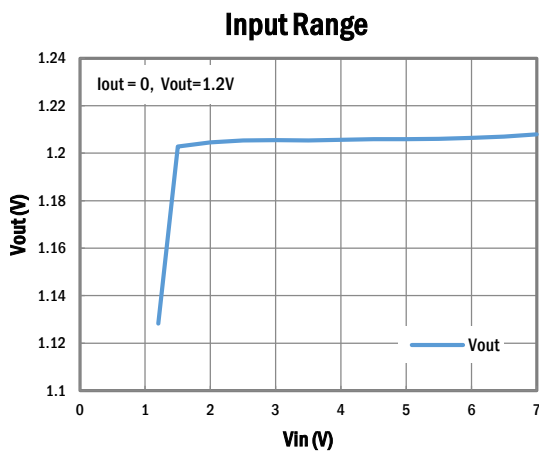
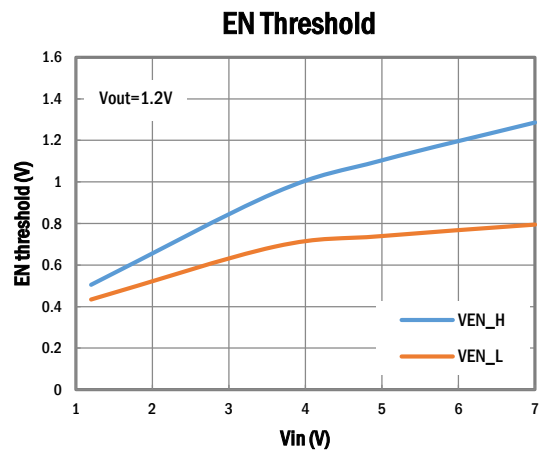
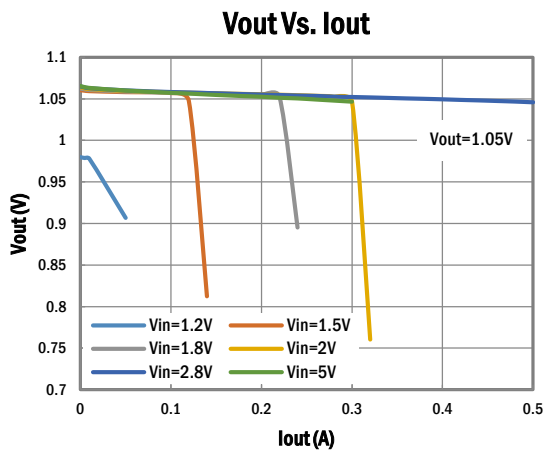
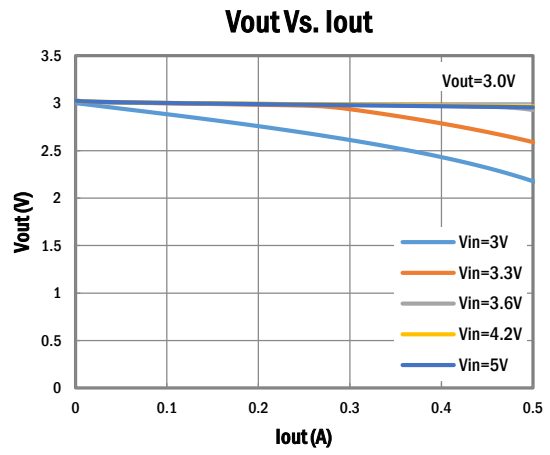
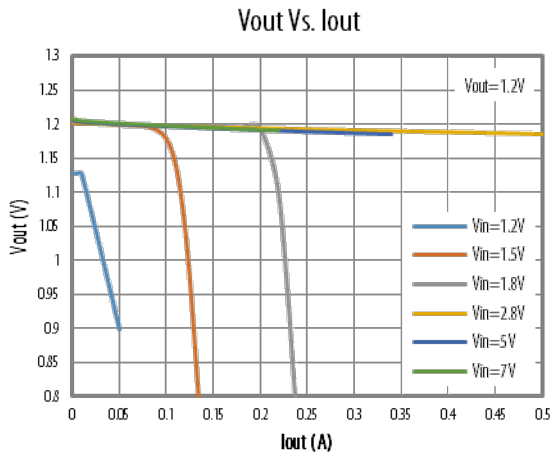

TYPICAL CHARACTERISTICS Cont'd

(Typical values are at $T_A = 25^\circ\text{C}$ unless otherwise specified.)

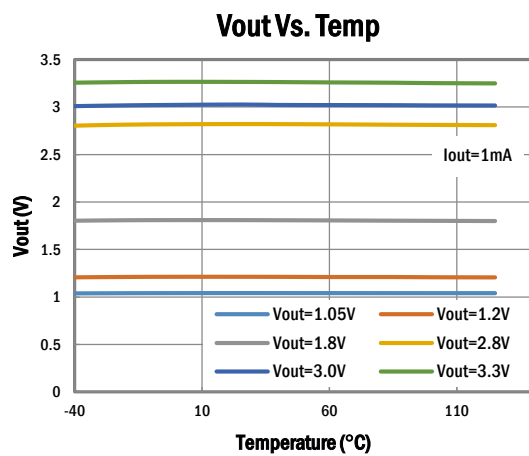
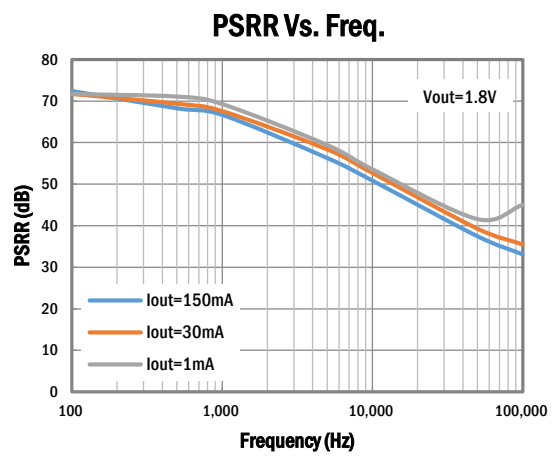
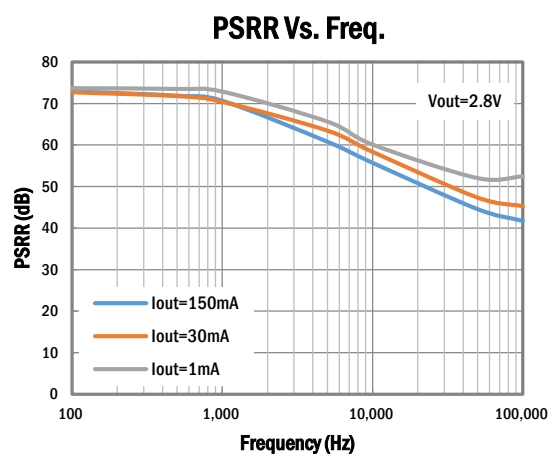
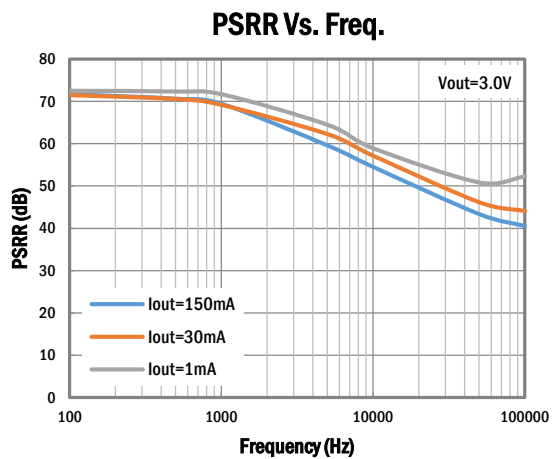
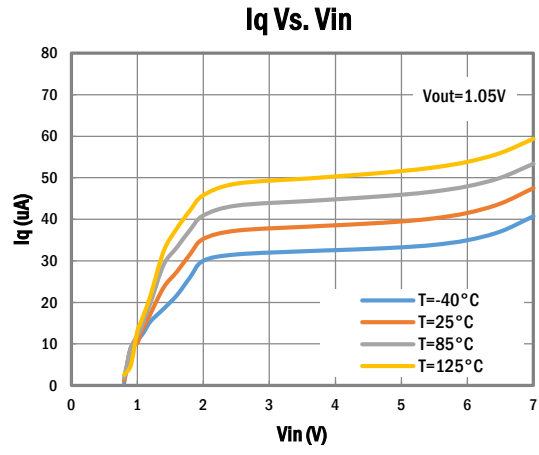
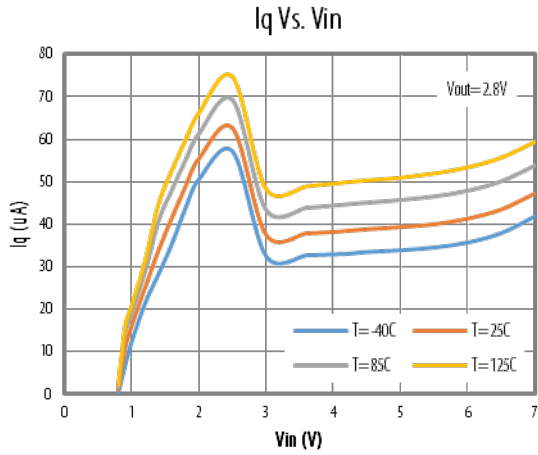

TYPICAL CHARACTERISTICS Cont'd

(Typical values are at $T_A = 25^\circ\text{C}$ unless otherwise specified.)

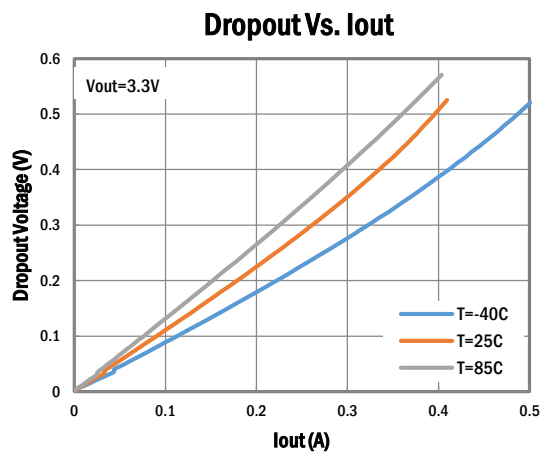
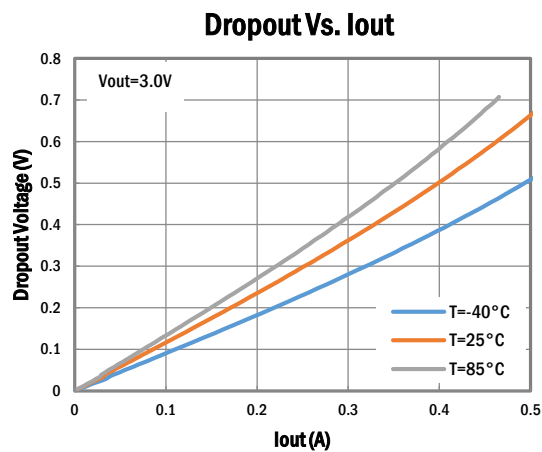
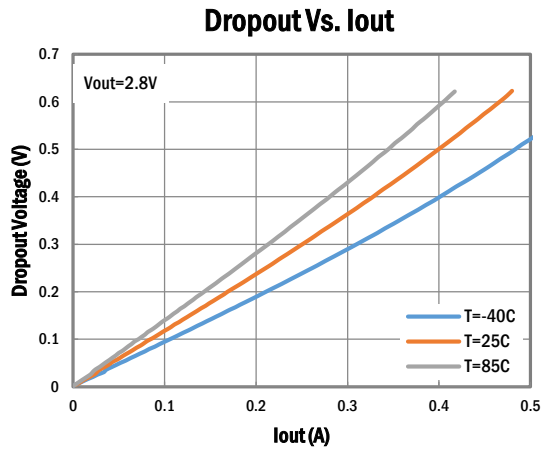
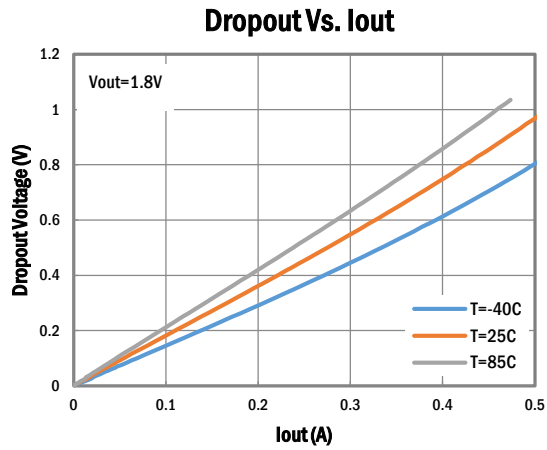
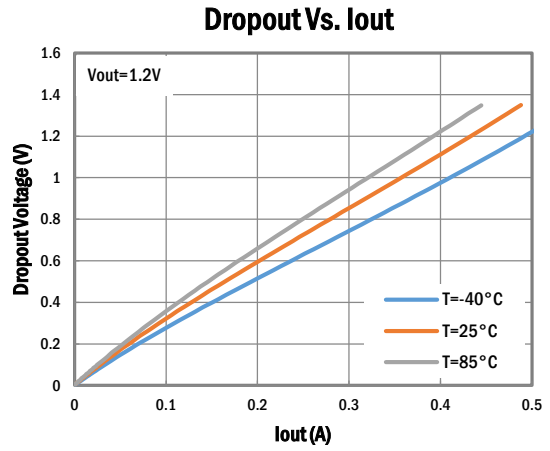
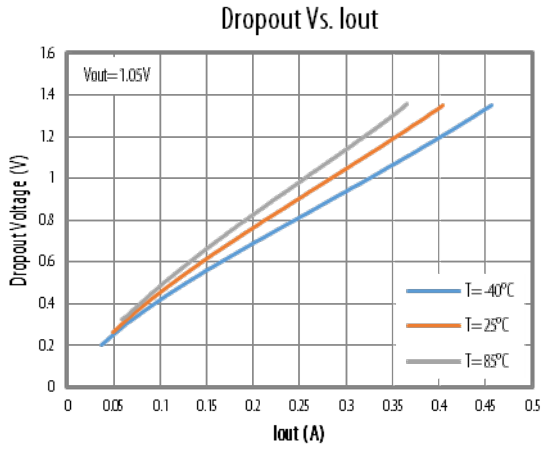

TYPICAL CHARACTERISTICS Cont'd

(Typical values are at $T_A = 25^\circ\text{C}$ unless otherwise specified.)

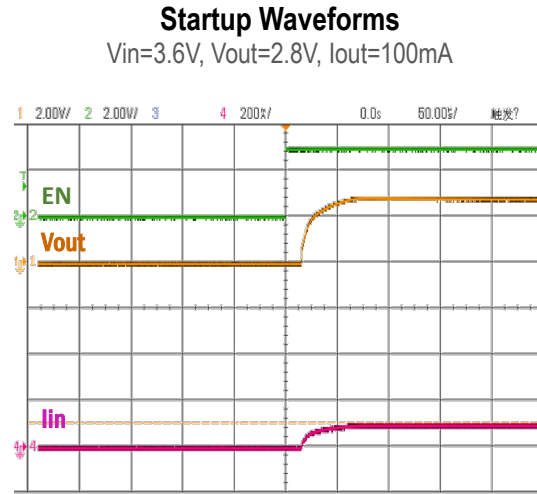
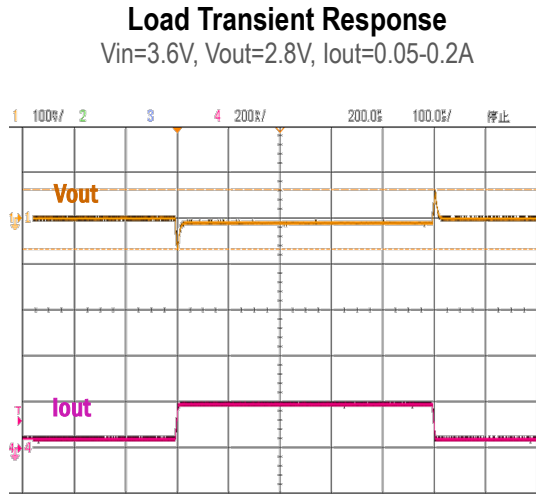

FUNCTIONAL BLOCK DIAGRAM

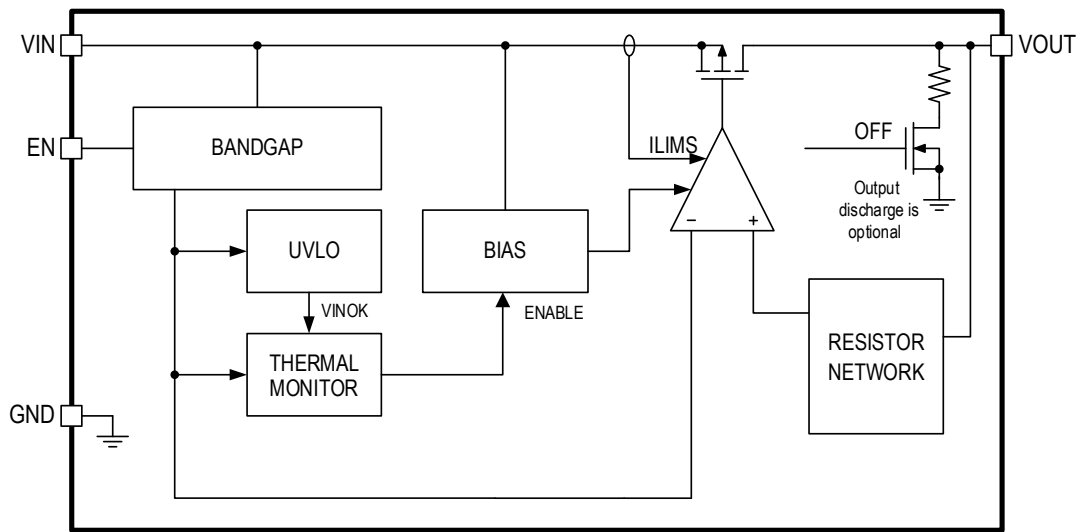

FUNCTIONAL DESCRIPTION

The ETA5053 family of LDO regulators has been optimized for application in noise-sensitive equipment. The device features low dropout voltages, high PSRR, low quiescent current, and enable-input to reduce supply currents to less than $1\mu\text{A}$ when the regulator is turned off.

Enable Sequence

ETA5053 is enabled when all below conditions happen. Otherwise, ETA5053 is in standby mode.

- ◆ EN pin voltage above Logic High level
- ◆ Junction Temperature is not at Over-Temperature Protection level.

Once all above conditions happen, ETA5053 first enables BANDGAP and BIAS then enables LDO core.

ETA5053 is completed forced in shutdown mode when EN pin is at below LOGIC_LOW that supply current is less than 1µA. Otherwise, part only shutdown the VOUT while other circuit still in operation. Once ETA5053 is in shutdown conditions, Output is discharged by resistor (optional).

Output Current Limit and Foldback Current Limit

ETA5053 family features an internal current limit. In normal operation, the ETA5053 limits output current to approximately 500mA. When current limiting engages, the output voltage scales back linearly until the over current condition ends.

In case output is in hard short conditions, ETA5053 also features an internal foldback limit that reduces the output current limit to a lower level, 250mA, then reduce power dissipation ratings of the package.

Over-Temperature Protection

Thermal protection disables the output when the junction temperature rises to approximately 150°C, allowing the device to cool down. When the junction temperature cools to approximately 120°C, the output circuitry is again enabled. Depending on power dissipation, thermal resistance, and ambient temperature, the thermal protection circuit may cycle on and off. This cycling limits regulator dissipation, protecting the device from damage as a result of overheating.

PACKAGE OUTLINE

Package: SOT23-5
ETA5053VXXXOS2F

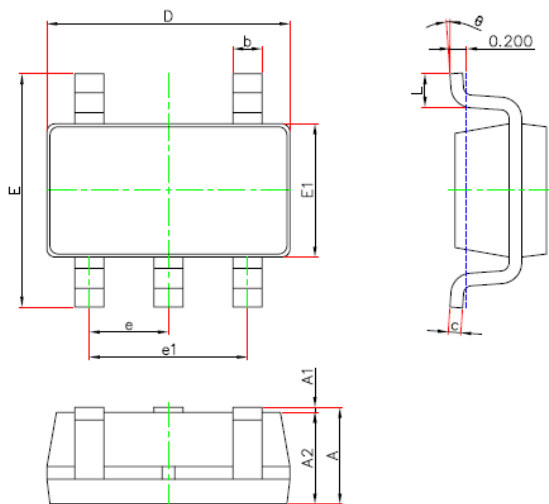

Symbol	Dimensions In Millimeters		Dimensions In Inches	
	Min.	Max.	Min.	Max.
A	1.050	1.250	0.041	0.049
A1	0.000	0.100	0.000	0.004
A2	1.050	1.150	0.041	0.045
b	0.300	0.500	0.012	0.020
c	0.100	0.200	0.004	0.008
D	2.820	3.020	0.111	0.119
E1	1.500	1.700	0.059	0.067
E	2.650	2.950	0.104	0.116
e	0.950(BSC)		0.037(BSC)	
e1	1.800	2.000	0.071	0.079
L	0.300	0.600	0.012	0.024
θ	0°		8°	

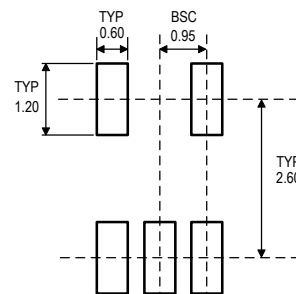

RECOMMENDED LAND PATTERN

AVAILABLE PART NUMBER

Part Description	Part Number	Package	Mark	Pcs/Reel
1.05V No Discharge DFN1x1-4	ETA5053V105NF1E	DFN1x1-4	2y <u>YW</u>	10000
1.05V with Discharge DFN1x1-4	ETA5053V105DF1E	DFN1x1-4	2x <u>YW</u>	10000
1.05V with fast Discharge DFN1x1-4	ETA5053V105WF1E	DFN1x1-4	2x1 <u>YW</u>	10000
1.1V No Discharge DFN1x1-4	ETA5053V110NF1E	DFN1x1-4	34 <u>YW</u>	10000
1.2V No Discharge DFN1x1-4	ETA5053V120NF1E	DFN1x1-4	3d <u>YW</u>	10000
1.2V with Discharge DFN1x1-4	ETA5053V120DF1E	DFN1x1-4	3c <u>YW</u>	10000
1.2V with fast Discharge DFN1x1-4	ETA5053V120WF1E	DFN1x1-4	3c1 <u>YW</u>	10000
1.5V No Discharge DFN1x1-4	ETA5053V150NF1E	DFN1x1-4	47 <u>YW</u>	10000
1.5V with Discharge DFN1x1-4	ETA5053V150DF1E	DFN1x1-4	46 <u>YW</u>	10000
1.5V with fast Discharge DFN1x1-4	ETA5053V150WF1E	DFN1x1-4	461 <u>YW</u>	10000
1.8V No Discharge DFN1x1-4	ETA5053V180NF1E	DFN1x1-4	51 <u>YW</u>	10000
1.8V with Discharge DFN1x1-4	ETA5053V180DF1E	DFN1x1-4	59 <u>YW</u>	10000
1.8V with fast Discharge DFN1x1-4	ETA5053V180WF1E	DFN1x1-4	591 <u>YW</u>	10000
2.5V No Discharge DFN1x1-4	ETA5053V250NF1E	DFN1x1-4	6z <u>YW</u>	10000
2.5V with Discharge DFN1x1-4	ETA5053V250DF1E	DFN1x1-4	6y <u>YW</u>	10000
2.5V with fast Discharge DFN1x1-4	ETA5053V250WF1E	DFN1x1-4	6y1 <u>YW</u>	10000
2.8V No Discharge DFN1x1-4	ETA5053V280NF1E	DFN1x1-4	7t <u>YW</u>	10000
2.8V with Discharge DFN1x1-4	ETA5053V280DF1E	DFN1x1-4	7s <u>YW</u>	10000
2.8V with fast Discharge DFN1x1-4	ETA5053V280WF1E	DFN1x1-4	7s1 <u>YW</u>	10000
3.0V No Discharge DFN1x1-4	ETA5053V300NF1E	DFN1x1-4	8d <u>YW</u>	10000
3.0V with Discharge DFN1x1-4	ETA5053V300DF1E	DFN1x1-4	8c	10000

3.0V with fast Discharge DFN1x1-4	ETA5053V300WF1E	DFN1x1-4	<u>YW</u> 8c1	10000
3.3V No Discharge DFN1x1-4	ETA5053V330NF1E	DFN1x1-4	<u>YW</u> 97	10000
3.3V with Discharge DFN1x1-4	ETA5053V330DF1E	DFN1x1-4	<u>YW</u> 96	10000
3.3V with fast Discharge DFN1x1-4	ETA5053V330WF1E	DFN1x1-4	<u>YW</u> 961	10000
			<u>YW</u>	
Part Description	Part Number	Package	Mark	Pcs/Reel
1.05V No Discharge DFN1x1-4	ETA5053V105ND1E	DFN1x1-4	2y	10000
1.05V with Discharge DFN1x1-4	ETA5053V105DD1E	DFN1x1-4	<u>YW</u> 2x	10000
1.05V with fast Discharge DFN1x1-4	ETA5053V105WD1E	DFN1x1-4	<u>YW</u> 2x1	10000
1.1V No Discharge DFN1x1-4	ETA5053V110ND1E	DFN1x1-4	<u>YW</u> 34	10000
1.2V No Discharge DFN1x1-4	ETA5053V120ND1E	DFN1x1-4	<u>YW</u> 3d	10000
1.2V with Discharge DFN1x1-4	ETA5053V120DD1E	DFN1x1-4	<u>YW</u> 3c	10000
1.2V with fast Discharge DFN1x1-4	ETA5053V120WD1E	DFN1x1-4	<u>YW</u> 3c1	10000
1.5V No Discharge DFN1x1-4	ETA5053V150ND1E	DFN1x1-4	<u>YW</u> 47	10000
1.5V with Discharge DFN1x1-4	ETA5053V150DD1E	DFN1x1-4	<u>YW</u> 46	10000
1.5V with fast Discharge DFN1x1-4	ETA5053V150WD1E	DFN1x1-4	<u>YW</u> 461	10000
1.8V No Discharge DFN1x1-4	ETA5053V180ND1E	DFN1x1-4	<u>YW</u> 51	10000
1.8V with Discharge DFN1x1-4	ETA5053V180DD1E	DFN1x1-4	<u>YW</u> 59	10000
1.8V with fast Discharge DFN1x1-4	ETA5053V180WD1E	DFN1x1-4	<u>YW</u> 591	10000
2.5V No Discharge DFN1x1-4	ETA5053V250ND1E	DFN1x1-4	<u>YW</u> 6z	10000
2.5V with Discharge DFN1x1-4	ETA5053V250DD1E	DFN1x1-4	<u>YW</u> 6y	10000
2.5V with fast Discharge DFN1x1-4	ETA5053V250WD1E	DFN1x1-4	<u>YW</u> 6y1	10000
2.8V No Discharge DFN1x1-4	ETA5053V280ND1E	DFN1x1-4	<u>YW</u> 7t	10000

2.8V with Discharge DFN1x1-4	ETA5053V280DD1E	DFN1x1-4	<u>YW</u> 7s	10000
2.8V with fast Discharge DFN1x1-4	ETA5053V280WD1E	DFN1x1-4	<u>YW</u> 7s1	10000
3.0V No Discharge DFN1x1-4	ETA5053V300ND1E	DFN1x1-4	<u>YW</u> 8d	10000
3.0V with Discharge DFN1x1-4	ETA5053V300DD1E	DFN1x1-4	<u>YW</u> 8c	10000
3.0V with fast Discharge DFN1x1-4	ETA5053V300WD1E	DFN1x1-4	<u>YW</u> 8c1	10000
3.3V No Discharge DFN1x1-4	ETA5053V330ND1E	DFN1x1-4	<u>YW</u> 97	10000
3.3V with Discharge DFN1x1-4	ETA5053V330DD1E	DFN1x1-4	<u>YW</u> 96	10000
3.3V with fast Discharge DFN1x1-4	ETA5053V330WD1E	DFN1x1-4	<u>YW</u> 961	10000

Part Description	Part Number	Package	Mark	Pcs/Reel
1.05V No Discharge SOT23-5	ETA5053V105NS2F	SOT23-5	2y <u>YW</u>	3000
1.05V with Discharge SOT23-5	ETA5053V105DS2F	SOT23-5	2x <u>YW</u>	3000
1.05V with fast Discharge SOT23-5	ETA5053V105WS2F	SOT23-5	2x1 <u>YW</u>	3000
1.2V No Discharge SOT23-5	ETA5053V120NS2F	SOT23-5	3d <u>YW</u>	3000
1.2V with Discharge SOT23-5	ETA5053V120DS2F	SOT23-5	3c <u>YW</u>	3000
1.2V with fast Discharge SOT23-5	ETA5053V120WS2F	SOT23-5	3c1 <u>YW</u>	3000
1.5V No Discharge SOT23-5	ETA5053V150NS2F	SOT23-5	47 <u>YW</u>	3000
1.5V with Discharge SOT23-5	ETA5053V150DS2F	SOT23-5	46 <u>YW</u>	3000
1.5V with fast Discharge SOT23-5	ETA5053V150WS2F	SOT23-5	461 <u>YW</u>	3000
1.8V No Discharge SOT23-5	ETA5053V180NS2F	SOT23-5	51 <u>YW</u>	3000
1.8V with Discharge SOT23-5	ETA5053V180DS2F	SOT23-5	59 <u>YW</u>	3000
1.8V with fast Discharge SOT23-5	ETA5053V180WS2F	SOT23-5	591 <u>YW</u>	3000
2.5V No Discharge SOT23-5	ETA5053V250NS2F	SOT23-5	6z <u>YW</u>	3000
2.5V with Discharge SOT23-5	ETA5053V250DS2F	SOT23-5	6y <u>YW</u>	3000
2.5V with fast Discharge SOT23-5	ETA5053V250WS2F	SOT23-5	6y1 <u>YW</u>	3000
2.8V No Discharge SOT23-5	ETA5053V280NS2F	SOT23-5	7t <u>YW</u>	3000
2.8V with Discharge SOT23-5	ETA5053V280DS2F	SOT23-5	7s <u>YW</u>	3000
2.8V with fast Discharge SOT23-5	ETA5053V280WS2F	SOT23-5	7s1 <u>YW</u>	3000
3.0V No Discharge SOT23-5	ETA5053V300NS2F	SOT23-5	8d <u>YW</u>	3000
3.0V with Discharge SOT23-5	ETA5053V300DS2F	SOT23-5	8c <u>YW</u>	3000
3.0V with fast Discharge SOT23-5	ETA5053V300WS2F	SOT23-5	8c1 <u>YW</u>	3000
3.3V No Discharge SOT23-5	ETA5053V330NS2F	SOT23-5	97 <u>YW</u>	3000
3.3V with Discharge SOT23-5	ETA5053V330DS2F	SOT23-5	96 <u>YW</u>	3000
3.3V with fast Discharge SOT23-5	ETA5053V330WS2F	SOT23-5	961 <u>YW</u>	3000

TAPE AND REEL INFORMATION

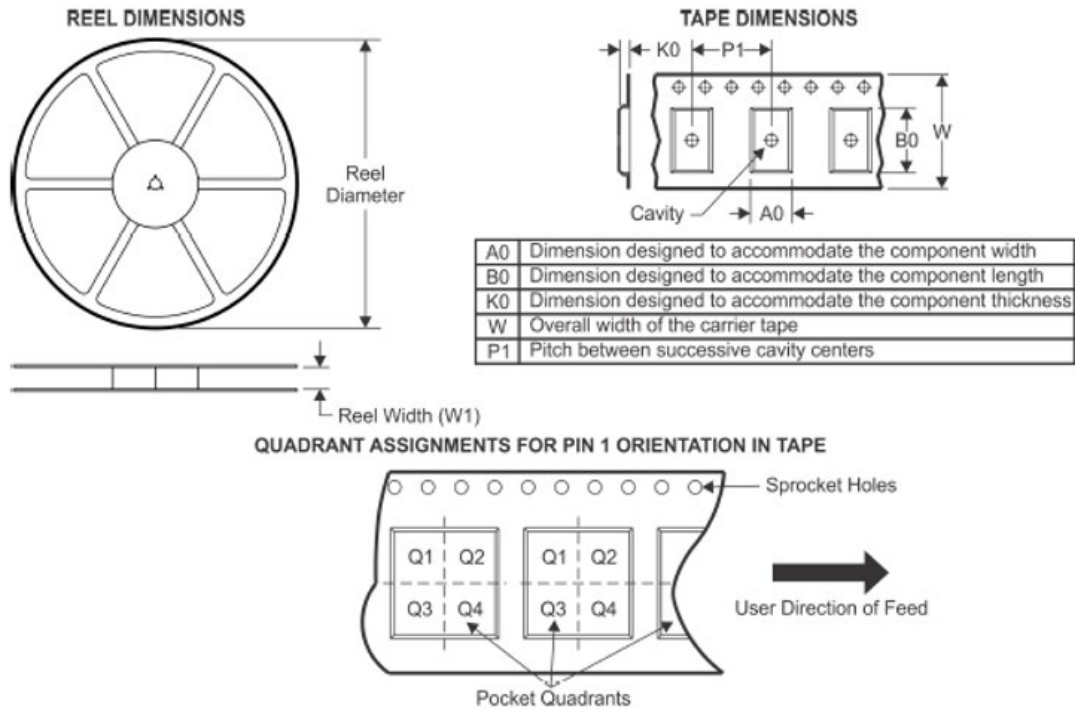

Device	Package Type	Pins	SPQ	Reel Diameter (mm)	Reel Width W1 (mm)	A0 (mm)	B0 (mm)	K0 (mm)	P1 (mm)	W (mm)	Pin1 Quadrant
ETA5053VXXXQF1E	DFN1x1-4	4	10000	180	9.5	1.16	1.16	0.5	2	8	Q1
ETA5053VXXXQD1E	DFN1x1-4	4	10000	178	9.5	1.15	1.15	0.55	2	8	Q1
ETA5053VXXXQS2F	SOT23-5	5	3000	180	9.5	3.17	3.23	1.37	4	8	Q3