

1.View and size(视图及尺寸)

Main technical indicators(主要技术指标)	
1.Mating (插拔次数)	5000
2.Working Temperature (温度)	-55~+150 °C
3.IP Rating (防护级别)	IP 50
4.Diameter of socket end(插合端直径)	φ1.3
5.Testing Voltage (测试电压)	1500V
6.Working Voltage (工作电压)	1350V
7.Rated Current (额定电流)	4.5A
8.Shell material(壳体材质)	Brass (chromium plating)/(nickel plating) fixation ring/ 黄铜 (镀铬)/(镀镍) 固定圈
9.Pin Material(插针材料)	Copper alloy gold plating(铜合金镀金)
10.Insulator material(绝缘体材质)	PPS

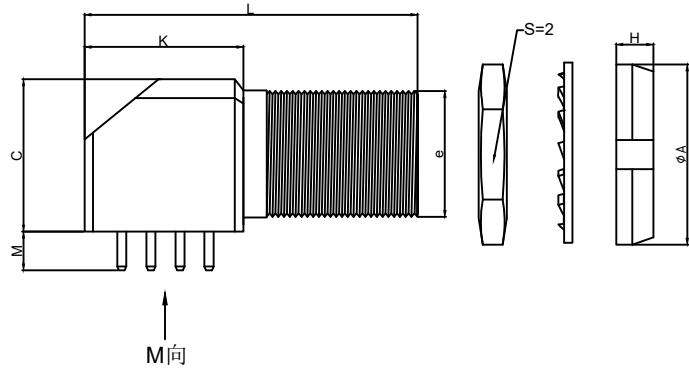

	A	L	K	C	e	M	H	S2
MM	14	27.0	13.3	14	M11*0.5	3.2	3.5	13
in	0.5512	1.063	0.5236	0.5512		0.126	0.1378	0.512

Sum up(总结)	
Series(系列)	B
Shell style/model (外壳样式/型号)	ZXG:Elbow receptacle for printed circuit with two nuts (solder or screw fixing, back panel mounting)/ 带两个螺母的印刷电路弯头插座, 焊料或螺钉固定, 背板安装
Button (按键)	A button(一个按键)
Termination type (终止类型)	Female print 90°PCB(印刷90° PCB)
Line diameter awg(线材直径)	20AWG-28AWG
Cable diameter φ (电缆直径)	0-0
Match plug(匹配插头)	TGG.1B.P02.CLAD52H

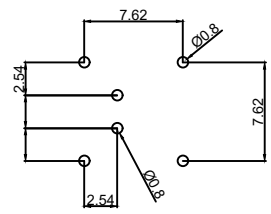

Pcb plate opening size (PCB板开孔尺寸)

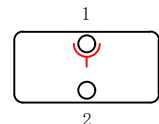

M-directional layout (M向排版位)

Location pin combination (定位销组合)			
(编号) Number	Number of positioning pins(定位销数量)	Angle(角度)	Series(系列)--1B
G	One(1)		(Zero degrees)0°
A	Two(2)	A	Thirty degrees(30°)
B	Two(2)		Sixty degrees(60°)
C	Two(2)		Ninety degrees(90°)
D	Two(2)	β	135 degrees(135°)
E	Two(2)		145 degrees(145°)
F	Two(2)		155 degrees(155°)
J	Two(2)	Y	Forty-five degrees(45°)
K	Two(2)		Seventy degrees(70°)
L	Two(2)		80 degrees(80°)

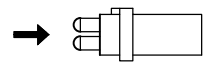

Boarded mother adhesive core (板接型母胶芯)

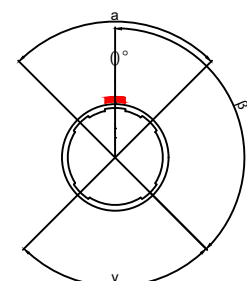

Positive view of the socket (插座正视图)

	A	B	C√	ANGLE	
5-10	±0.02	±0.05	±0.1	0°-30°	±0.1°
50-100	±0.1	±0.15	±0.2	61°-90°	±0.5°
50-100	±0.15	±0.2	±0.25		
100-	±0.15%	±0.20%	±0.25%		

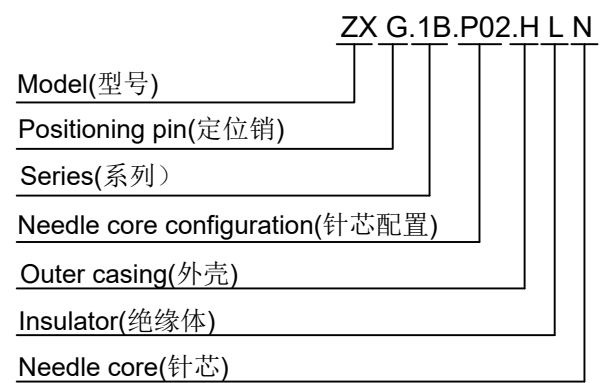

DESIGNED(设计)		DATE(日期)		SCALE(比例)	N/A(不适用)	MODEL TYPE 型号类型: ZXG.1B.P02.HLN
CHECKED(校对)		DATE(日期)		VIEW(视图)		PART NO. 1B2 core socket 名称: 1B2芯插座
APPROVED(审核)		DATE(日期)		UNIT(单位)	MM	DWG NO.:
REVISIONS				MATERIAL (材料)		
www.helloxkb.com www.helloxkb.cn				XKB INDUSTRIAL PRECISION CO.,LIMITED		WEIGHT(重量) SHEET(表) REVISION(修订)
						1/1 A0