

MHC 1005-4532 S Series

Specification

Product Name	High Current Chip Bead
Series	MHC S Series
Size	EIAJ 1005-4532



Chip Ferrite Bead for High Current (MHC-S Series) Engineering Spec.

■ FEATURES

- Combination of high frequency noise suppression with capability of handling high current
- The current rating up to 6 Amps with low DCR

■ APPLICATIONS

- High current DC power lines
- Circuits where a stable ground is unavailable

■ SHAPES AND DIMENSIONS

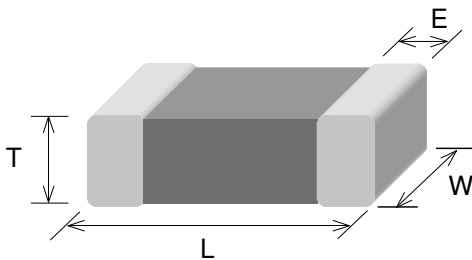

Unit: mm

TYPE	1005 (EIA 0402)	1608 (EIA 0603)	2012 (EIA 0805)	3216 (EIA 1206)	3225 (EIA 1210)	4516 (EIA 1806)	4532 (EIA 1812)
L	1.00±0.10	1.60±0.15	2.00±0.20	3.20±0.20	3.20±0.20	4.50±0.25	4.50±0.25
W	0.50±0.10	0.80±0.15	1.25±0.20	1.60±0.20	2.50±0.20	1.60±0.20	3.20±0.25
T	0.50±0.10	0.80±0.15	0.90±0.20	1.10±0.20	1.30±0.20	1.60±0.20	1.50±0.25
E	0.25±0.10	0.30±0.20	0.50±0.30	0.50±0.30	0.50±0.30	0.60±0.40	0.60±0.40

■ PART NUMBER CODE

<u>MHC</u>	<u>1608</u>	<u>S</u>	<u>10</u>	<u>2</u>	<u>Z</u>	<u>B</u>	<u>P</u>	<u>A80</u>
1	2	3	4	5	6	7	8	9

- 1 Series Name**
2 Size Code: the first two digitals : length(mm), the last two digitals : width(mm)
3 Material Code
4 Impedance(Ω) \pm 25% } (ex : 600=60 Ω ; 121=120 Ω)
5 Fixed Decimal Point
6 Rated Current Code

L=1000mA	M=1500mA	N=2000mA	P=2500mA	Q=3000mA
R=4000mA	U=5000mA	W=6000mA	Z=other(refer to code 9)	

- 7 Soldering:** Green Parts: A— Soldering Lead-Free B— Lead-Free for whole chip
8 Packaging: P - Embossed paper tape, 7" reel.
 E - Embossed plastic tape, 7" reel.
9 1A2=1.2A ; A80=800mA

■ PART NUMBER AND CHARACTERISTICS TABLE

Part No.	Impedance (Ω) +/-25%	Test Freq.	DCR(Ω)	Rated Current
		(MHz)	(Max.)	(mA)
MHC1005 Series				
MHC1005S100NBP	10	100	0.09	2000
MHC1005S300NBP	30	100	0.09	2000
MHC1005S600LBP	60	100	0.2	1000
MHC1005S121MBP	120	100	0.15	1500
MHC1608 Series				
MHC1608S300QBP	30	100	0.04	3000
MHC1608S600QBP	60	100	0.04	3000
MHC1608S800QBP	80	100	0.04	3000
MHC1608S121PBP	120	100	0.07	2500
MHC1608S221NBP	220	100	0.09	2000
MHC1608S301NBP	300	100	0.09	2000
MHC1608S471LBP	470	100	0.2	1000
MHC1608S601LBP	600	100	0.2	1000
MHC1608S102ZBPA80	1000	100	0.25	800

Part No.	Impedance (Ω) +/-25%	Test Freq.	DCR(Ω)	Rated Current
		(MHz)	(Max.)	(mA)
MHC2012S310WBP	31	100	0.015	6000
MHC2012S400RBP	40	100	0.03	4000
MHC2012S600QBP	60	100	0.04	3000
MHC2012S800UBP	80	100	0.02	5000
MHC2012S121UBP	120	100	0.02	5000
MHC2012S221QBP	220	100	0.04	3000
MHC2012S301NBP	300	100	0.09	2000
MHC2012S331NBP	330	100	0.09	2000
MHC2012S601NBP	600	100	0.09	2000
MHC3216 Series				
MHC3216S300WBE	30	100	0.015	6000
MHC3216S500WBE	50	100	0.015	6000
MHC3216S800RBE	80	100	0.03	4000
MHC3216S121WBE	120	100	0.015	6000
MHC3216S601PBE	600	100	0.07	2500
MHC3216S122LBE	1200	100	0.2	1000
MHC3225 Series				
MHC3225S600MBE	60	100	0.15	1500
MHC3225S102NBE	1000	50	0.09	2000
MHC4516 series				
MHC4516S600WBE	60	100	0.015	6000
MHC4516S851MBE	850	100	0.15	1500
MHC4532 series				
MHC4532S800ZBE9A0	80	100	0.01	9000
MHC4532S121WBE	120	100	0.015	6000
MHC4532S601QBE	600	50	0.04	3000
MHC4532S132QBE	1300	60	0.04	3000

Test Level : 250 mV

Test Instruments :	HP4291B
	HP4338A/B MILLIOHMMETER
	Agilent 8720ES S-PARAMETER
	HP6632B SYSTEM DC POWER SUPPLY

** For special part number which is not shown in the above table, please refer to appendix.

■ TAPE AND REEL SPECIFICATIONS

PLASTIC CARRIER

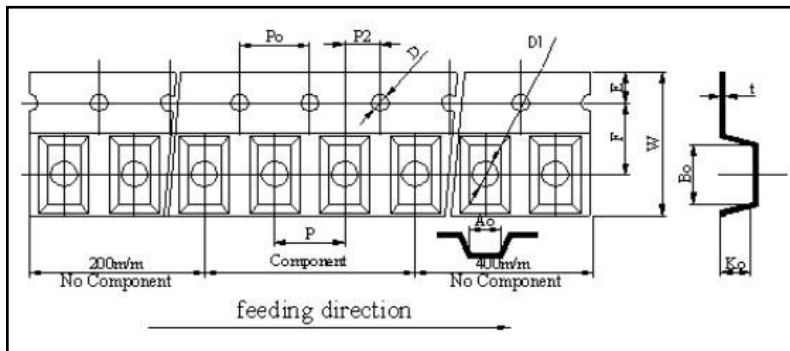

PAPER CARRIER

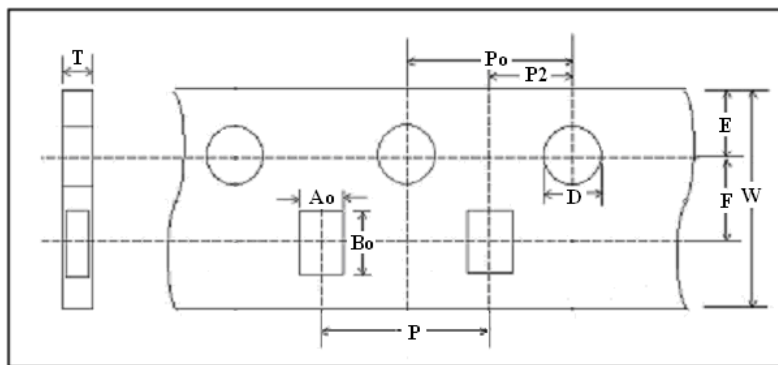

■ TAPING DIMENSIONS

Unit: mm

Size	4532	4516	3225	3216	2012	1608	1005
Symbol	PLASTIC	PLASTIC	PLASTIC	PLASTIC	PAPER	PAPER	PAPER
W	12.0±0.10	11.7~12.3	7.70~8.30	7.90~8.30	8.00±0.10	8.00±0.10	8.00±0.10
P	8.00±0.10	4.00±0.10	4.00±0.10	4.00±0.10	4.00±0.10	4.00±0.10	2.00±0.05
E	1.75±0.10	1.75±0.10	1.75±0.10	1.75±0.10	1.75±0.10	1.75±0.10	1.75±0.05
F	5.50±0.05	5.50±0.05	3.50±0.05	3.50±0.05	3.50±0.10	3.50±0.10	3.50±0.05
D	1.55±0.05	1.55±0.05	1.55±0.05	1.55±0.05	1.56±0.10	1.56±0.10	1.55±0.05
D1	1.50~1.75	1.50~1.75	0.95~1.20	0.95~1.20	NA	NA	NA
P _o	4.00±0.10	4.00±0.10	4.00±0.10	4.00±0.10	4.00±0.10	4.00±0.10	4.00±0.10
P _{o10}	40.0±0.20	40.0±0.20	40.0±0.20	40.0±0.20	40.0±0.20	NA	NA
P ₂	2.00±0.05	2.00±0.05	2.00±0.05	2.00±0.05	2.00±0.10	2.00±0.10	2.00±0.05
A _o	3.66±0.10	1.83±0.10	2.57±0.10	1.85±0.10	1.50±0.05	1.05±0.05	0.62±0.03
B _o	4.95±0.10	4.85±0.10	3.40±0.10	3.43±0.10	2.30±0.05	1.85±0.05	1.12±0.03
K _o (T)	1.83±0.10	1.83±0.10	1.32±0.10	1.22±0.10	0.95±0.05	0.95±0.05	0.60±0.03
t	0.23±0.10	0.29±0.10	0.25±0.10	0.25±0.10	NA	NA	NA

REEL DIMENSIONS

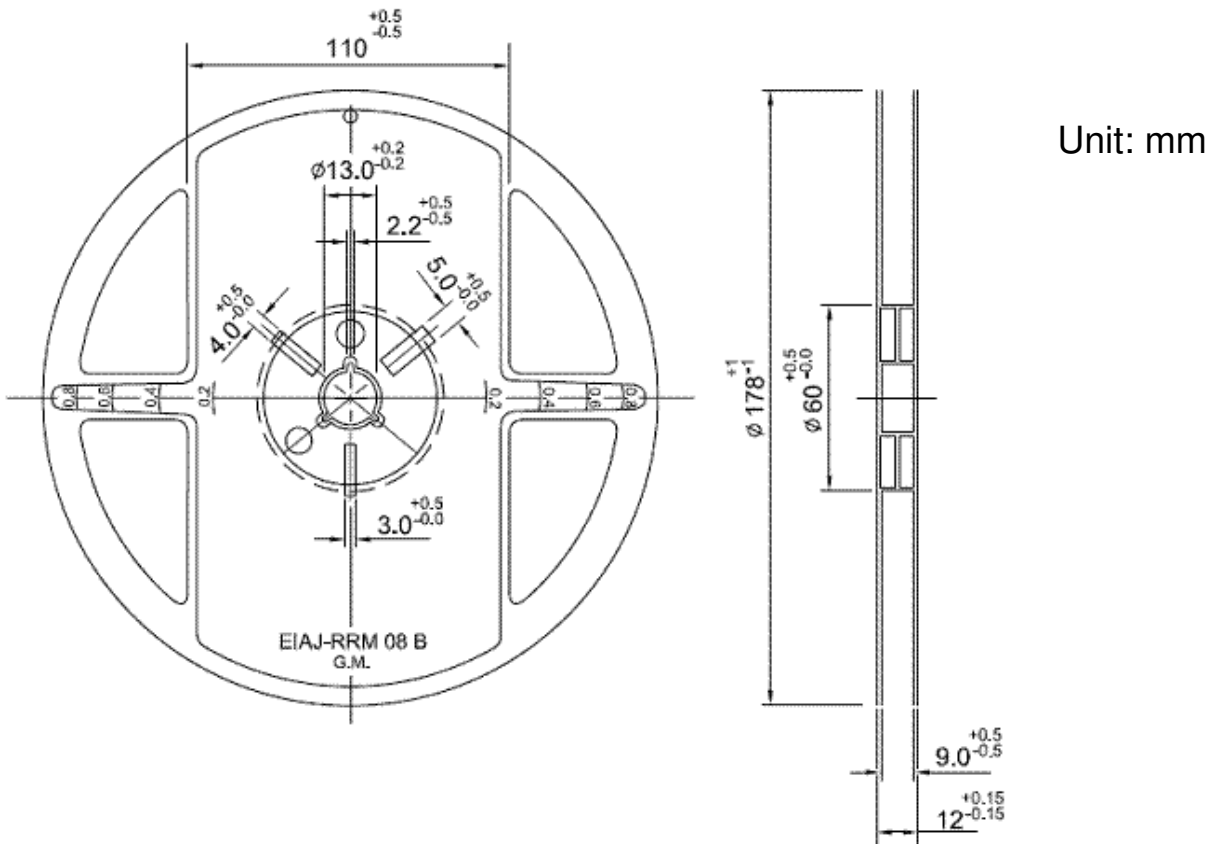

Reel Packaging Quantity								
PART SIZE (EIA SIZE)		1005 (0402)	1608 (0603)	2012 (0805)	3216 (1206)	3225 (1210)	4516 (1806)	4532 (1812)
7" REEL	Qty. (pcs)	10,000	4,000	4,000	3,000	2,000	2,000	1,000

The Contents of a box :

- 4532(1812): 4 reels / inner box;
- 4516(1806): 4 reels / inner box;
- 3225(1210): 5 reels / inner box;
- 3216(1206): 5 reels / inner box;
- 2012(0805): 5 reels / inner box;
- 1608(0603): 5 reels / inner box;
- 1005(0402): 5 reels / inner box.

■ RECOMMENDED SOLDERING CONDITIONS

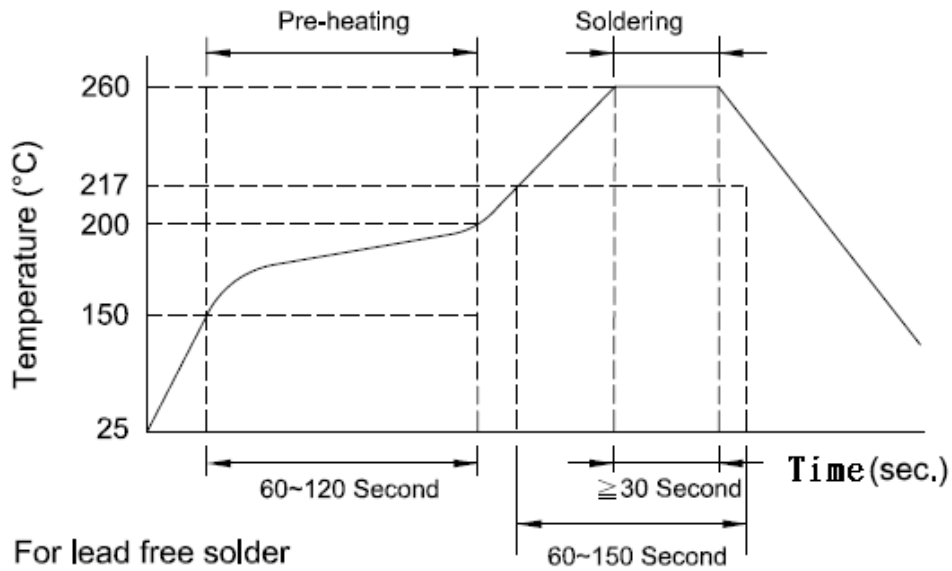

■ LAND PATTERNS FOR REFLOW SOLDERING

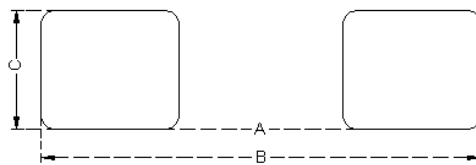

■ SOLDER LAND INFORMATION

Unit: mm (inches)

Size	A	B	C
1005	0.4 ~ 0.6 (0.015 ~ 0.023)	1.6 ~ 2.6 (0.063 ~ 0.102)	0.4 ~ 0.7 (0.016 ~ 0.027)
1608	0.5 ~ 0.7 (0.019 ~ 0.027)	2.1 ~ 3.1 (0.083 ~ 0.122)	0.65 ~ 0.95 (0.026 ~ 0.037)
2012	1.0 ~ 1.2 (0.039 ~ 0.047)	3.0 ~ 4.0 (0.118 ~ 0.157)	0.8 ~ 1.1 (0.031 ~ 0.043)
3216	2.0 ~ 2.4 (0.079 ~ 0.094)	4.2 ~ 5.2 (0.165 ~ 0.204)	1.0 ~ 1.4 (0.039 ~ 0.055)
3225	2.1 ~ 2.3 (0.082 ~ 0.090)	4.2 ~ 5.2 (0.165 ~ 0.204)	2.2 ~ 2.5 (0.086 ~ 0.098)
4516	3.4 ~ 3.7 (0.133 ~ 0.145)	6.3 ~ 7.3 (0.248 ~ 0.287)	1.3 ~ 1.7 (0.051 ~ 0.067)
4532	3.4 ~ 3.7 (0.133 ~ 0.145)	6.3 ~ 7.3 (0.248 ~ 0.287)	2.9 ~ 3.2 (0.144 ~ 0.126)

■ RELIABILITY AND TEST CONDITION

Test item	Test condition	Criteria
Temperature Cycle	<ul style="list-style-type: none"> a. Temperature : -40 ~ +85°C b. Cycle : 100 cycles c. Dwell time : 30minutes d. Measurement : at ambient temperature 24 hrs after test completion 	<ul style="list-style-type: none"> a. No mechanical damage b. Impedance value should be within ± 20 % of the initial value
Operational Life	<ul style="list-style-type: none"> a. Temperature : 125°C ± 5°C b. Test time : 1000 hrs c. Apply current : full rated current d. Measurement : at ambient temperature 24 hrs after test completion 	<ul style="list-style-type: none"> a. No mechanical damage b. Impedance value should be within ± 20 % of the initial value
Rated Current Test	<ul style="list-style-type: none"> a. Apply current : full rated current / 5min 	Temperature rise should be less than 40°C

Test item	Test condition	Criteria
Biased Humidity	<ul style="list-style-type: none"> a. Temperature : 40°C ± 2°C b. Humidity : 90 ~ 95 % RH c. Test time : 1000 hrs d. Apply current : full rated current e. Measurement : at ambient temperature 24 hrs after test completion 	<ul style="list-style-type: none"> a. No mechanical damage b. Impedance value should be within ± 20 % of the initial value
Resistance to Solder Heat	<ul style="list-style-type: none"> a. Solder temperature : 260 ± 5°C b. Flux : Rosin c. DIP time : 10 ± 1 sec 	<ul style="list-style-type: none"> a. More than 95 % of terminal electrode should be covered with new solder b. No mechanical damage c. Impedance value should be within ± 20 % of the initial value
Adhesive Test	<ul style="list-style-type: none"> a. Reflow temperature : 245°C It shall be Soldered on the substrate applying direction parallel to the substrate b. Apply force(F) : 5 N c. Test time : 10 sec 	<ul style="list-style-type: none"> a. No mechanical damage b. Soldering the products on PCB after the pulling test force > 5 N
Steam Aging Test	<ul style="list-style-type: none"> a. Temperature : 93°C b. Test time : 4 hrs(MHC1005) Others : 8 hrs c. Solder temperature : 235 ± 5°C d. Flux : Rosin e. DIP time : 5 ± 1 sec 	<p>More than 95 % of terminal electrode should be covered with new solder</p>

■ GENERAL TECHNICAL DATA

Operating temperature range : - 55°C ~ +125°C
 Storage Condition : Less than 40°C and 70% RH
 Storage Time: 6 months(Size:1005)
 12 months(Size:1608 above)
 Soldering method: Reflow or Wave Soldering