



DESCRIPTION

This series of fixed-voltage monolithic integrated circuit voltage regulators is designed for a wide range of applications. These applications include on-card regulation for elimination of noise and distribution problems associated with single-point regulation. In addition, they can be used with power-pass elements to make high-current voltage regulators. Each of these regulators can deliver up to 100mA of output current. The internal limiting and thermal shutdown features of these regulators make them essentially immune to overload. When used as a replacement for a Zener diode-resistor combination, an effective improvement in output impedance can be obtained together with lower-bias current.

FEATURES

- 3-Terminal Regulators
- Output Current Upto 100mA
- No External Components
- Internal Thermal Overload Protection
- Internal Short-Circuit Limiting

PIN CONNECTIONS

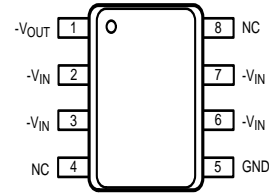

SOP-8

Absolute maximum ratings over operating temperature range (unless otherwise noted)

Input voltage	-35	V
Operating free-air, case, or virtual junction temperature range	0 to 150	°C
Storage temperature range	-65 to 150	
Lead temperature 1.6 mm (1/16 inch) from case for 10 seconds	260	

Recommended operating conditions

Parameter	MIN	MAX	UNIT
Input voltage, V_I	-17.5	-30	V
Output current, I_o		100	mA
Operating temperature range, T_J	-25	85	°C



**Electrical characteristics at specified virtual junction temperature, $V_I=-26V$,
 $I_O=40mA$ (unless otherwise noted)**

PARAMETER	TEST CONDITIONS*	MIN	TYP	MAX	UNIT	
Output voltage**		25°C	-17.3	-18	-18.7	V
	$I_O=1mA$ to 40mA $V_I=-20.5V$ to -33V	0 to 125 °C	-17.1	-18	-18.9	
	$I_O=1mA$ to 70mA		-17.1	-18	-18.9	
Input regulation	$V_I=-20.5V$ to -33V	25°C		70	325	mV
	$V_I=-22V$ to -33V			60	275	
Ripple rejection	$V_I=-21.5V$ to -31.5V, $f=120Hz$	25°C	33	48		dB
Output regulation	$I_O=1mA$ to 100mA	25°C		27	170	mV
	$I_O=1mA$ to 40mA			19	85	
Output noise voltage	$f=10Hz-100Hz$	25°C		150		µV
Dropout voltage		25°C		1.7		V
Bias current		25°C			6.5	mA
		125°C			6	
Bias current change	$V_I=-22V$ to -33V	0 to 125 °C			1.5	
	$I_O=1mA$ to 40mA				0.1	

*Pulse testing techniques are used to maintain the junction temperature as close to the ambient temperature as possible. Thermal effects must be taken into account separately. All characteristics are measured with a 0.33 µF capacitor across the input and a 0.1 µF capacitor across the output.

**This specification applies only for dc power dissipation permitted by absolute maximum ratings.



SOP-8

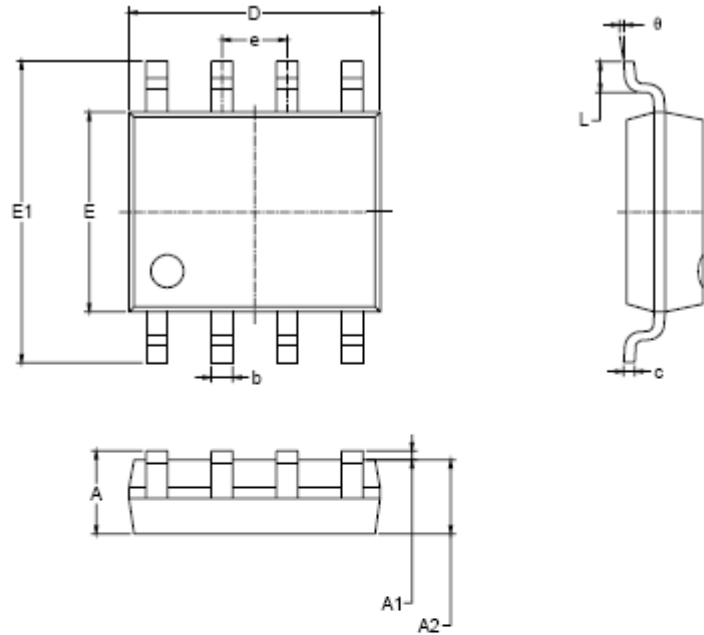

Symbol	Dimensions In Millimeters		Dimensions In Inches	
	MIN	MAX	MIN	MAX
A	1.350	1.750	0.053	0.069
A1	0.100	0.250	0.004	0.010
A2	1.350	1.550	0.053	0.061
b	0.330	0.510	0.013	0.020
c	0.170	0.250	0.008	0.010
D	4.700	5.100	0.185	0.200
E	3.800	4.000	0.150	0.157
E1	5.800	6.200	0.228	0.244
e	1.27 BSC		0.050 BSC	
L	0.400	1.270	0.016	0.050
θ	0°	8°	0°	8°



Attention

- Any and all HUA XUAN YANG ELECTRONICS products described or contained herein do not have specifications that can handle applications that require extremely high levels of reliability, such as life-support systems, aircraft's control systems, or other applications whose failure can be reasonably expected to result in serious physical and/or material damage. Consult with your HUA XUAN YANG ELECTRONICS representative nearest you before using any HUA XUAN YANG ELECTRONICS products described or contained herein in such applications.
- HUA XUAN YANG ELECTRONICS assumes no responsibility for equipment failures that result from using products at values that exceed, even momentarily, rated values (such as maximum ratings, operating condition ranges, or other parameters) listed in products specifications of any and all HUA XUAN YANG ELECTRONICS products described or contained herein.
- Specifications of any and all HUA XUAN YANG ELECTRONICS products described or contained herein stipulate the performance, characteristics, and functions of the described products in the independent state, and are not guarantees of the performance, characteristics, and functions of the described products as mounted in the customer's products or equipment. To verify symptoms and states that cannot be evaluated in an independent device, the customer should always evaluate and test devices mounted in the customer's products or equipment.
- HUA XUAN YANG ELECTRONICS CO.,LTD. strives to supply high-quality high-reliability products. However, any and all semiconductor products fail with some probability. It is possible that these probabilistic failures could give rise to accidents or events that could endanger human lives, that could give rise to smoke or fire, or that could cause damage to other property. When designing equipment, adopt safety measures so that these kinds of accidents or events cannot occur. Such measures include but are not limited to protective circuits and error prevention circuits for safe design, redundant design, and structural design.
- In the event that any or all HUA XUAN YANG ELECTRONICS products(including technical data, services) described or contained herein are controlled under any of applicable local export control laws and regulations, such products must not be exported without obtaining the export license from the authorities concerned in accordance with the above law.
- No part of this publication may be reproduced or transmitted in any form or by any means, electronic or mechanical, including photocopying and recording, or any information storage or retrieval system, or otherwise, without the prior written permission of HUA XUAN YANG ELECTRONICS CO.,LTD.
- Information (including circuit diagrams and circuit parameters) herein is for example only ; it is not guaranteed for volume production. HUA XUAN YANG ELECTRONICS believes information herein is accurate and reliable, but no guarantees are made or implied regarding its use or any infringements of intellectual property rights or other rights of third parties.
- Any and all information described or contained herein are subject to change without notice due to product/technology improvement, etc. When designing equipment, refer to the "Delivery Specification" for the HUA XUAN YANG ELECTRONICS product that you intend to use.