

# PRODUCT SPECIFICATION DRAWING

**P2RFD-1671-SS**

**FINISH:**  
BODIES &  
COMPONENTS: WHITE BRONZE

HEX NUT: PASSIVATED PER QQ-P-35C, TYPE II

PINS: SILVER

**PERFORMANCE:**  
IMPEDANCE: 50 OHMS  
VP: 77%  
FREQ. RANGE: DC TO 7.5 GHz  
DELAY: 110ps  
VSWR: <1.10:1 @ DC-7.5 GHz  
INSERTION LOSS: <-.1db @ 7.5 GHz  
3rd ORDER IM: <-160 dBc IN PCS BAND w/2+43 dB TONES  
DIN TORQUE: 15 ftLb  
OPERATING  
TEMP RANGE: -55 °C TO +150 °C

**MATERIAL:**  
BODIES,  
COMPONENTS  
& PIN: BRASS

CONTACT: BERYLLIUM COPPER

HEX NUT: STAINLESS STEEL PER AMS-5640, TYPE 303,  
COND. A

O-RING: SILICONE RUBBER, ZZ-R-765 DUROMETER 70

INSULATOR: PTFE PER ASTM-D1710

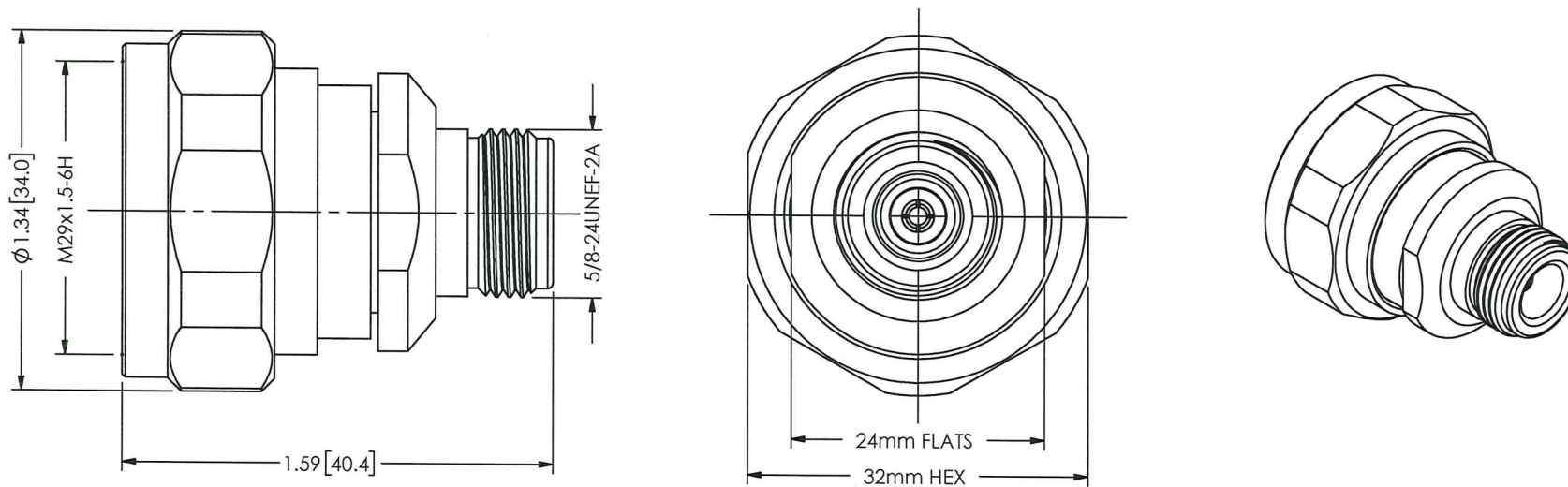

UNLESS OTHERWISE SPECIFIED  
DIMENSIONS ARE IN INCHES  
& [MILLIMETERS]

**PROPRIETARY**

THE INFORMATION HEREIN IS CONFIDENTIAL AND PROPRIETARY. NO DISCLOSURE, REPRODUCTION, OR FURTHER DISSEMINATION MAY BE MADE WITHOUT THE EXPRESSED WRITTEN CONSENT OF RF INDUSTRIES.

**RFP<sup>2</sup> RF PRECISION PRODUCTS**  
A DIVISION OF RF INDUSTRIES

7610 MIRAMAR ROAD, SAN DIEGO, CA 92126-4202  
(858) 549-6340 - FAX (858) 549-6345 - RFP2@RFINDUSTRIES.COM

TITLE:  
**7/16 DIN PLUG TO  
N JACK ADAPTER**

REV	DESCRIPTION	DATE	APPROVED
-	ENGINEERING RELEASE	10/10/10	JDMc
A	UPDATED COUPLING NUT DESIGN, DWG. FORMAT & SPECS	05/15/15	JDMc
B	UPDATED SPECS	10/21/21	JDMc

**RoHS  
COMPLIANT**

DRAWN BY:	C. ZUNIGA	10/21/21
ENG APPROVAL:	<i>[Signature]</i>	
ORJ. DRAWN:	C. ZUNIGA	10/10/10

SIZE	CODE	DWG. NO.	REV
A	000000	P2RFD-1671-SS	B
SHEET 1 OF 1			