

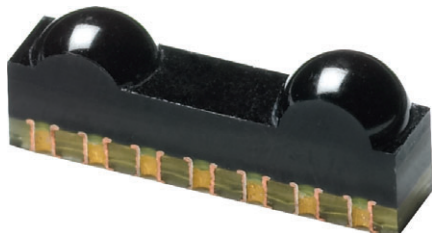

# Infrared Transceiver, 9.6 kbit/s to 115.2 kbit/s (SIR) for IrDA® Applications



20206-1

## DESCRIPTION

TFBS4650 is an infrared transceiver that supports data rates up to 115 kbit/s per the IrDA standard. The link distance is up to 1 meter. The transceiver includes a PIN photodiode, an infrared emitter, and a low power control IC. These components have not been qualified according to automotive specifications.

## FEATURES

- Compliant to the IrDA physical layer specification
- Standard IrDA link distance of 1 m
- Low power consumption, typically less than 70  $\mu$ A
- Less than 1  $\mu$ A in shutdown mode
- Material categorization: for definitions of compliance please see [www.vishay.com/doc?99912](http://www.vishay.com/doc?99912)



**RoHS**  
COMPLIANT  
HALOGEN  
**FREE**  
**GREEN**  
(5-2008)

## APPLICATIONS

- Short-distance wireless communication and data transfer
- Use in environments where RF is problematic

## DESIGN SUPPORT TOOLS

- [3D model](#)
- [Window size calculator](#)
- [Symbols and terminology](#)
- [IRDC protocol](#)
- [Reference layouts and circuit diagrams](#)

## LINKS TO ADDITIONAL RESOURCES



## FUNCTIONAL BLOCK DIAGRAM

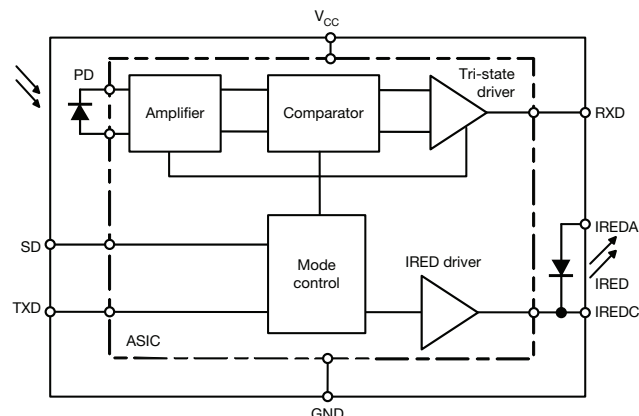

19283



PRODUCT SUMMARY					
PART NUMBER	DATA RATE (kbit/s)	DIMENSIONS H x L x W (mm x mm x mm)	LINK DISTANCE (m)	OPERATING VOLTAGE (V)	IDLE SUPPLY CURRENT (mA)
TFBS4650	115.2	1.6 x 6.8 x 2.8	0 to ≥ 1	2.4 to 5.5	0.07

PARTS TABLE		
PART	DESCRIPTION	QTY/REEL
TFBS4650-TR1	Oriented in carrier tape for side view surface mounting	1000 pcs
TFBS4650-TR3	Oriented in carrier tape for side view surface mounting	2500 pcs
TFBS4650-TT3	Oriented in carrier tape for top view surface mounting	2500 pcs

PIN DESCRIPTION				
PIN NUMBER	SYMBOL	DESCRIPTION	I/O	ACTIVE
1	IREDA	IREDA anode, connected via a current limiting resistor to V <sub>CC2</sub> . A separate unregulated power supply can be used.		
2	IREDC	IREDC cathode, do not connect for standard operation.		
3	TXD	Transmitter data input. Setting this input above the threshold turns on the transmitter. This input switches the IRED with the maximum transmit pulse width of about 100 μs.	I	High
4	RXD	Receiver output. Normally high, goes low for a defined pulse duration with the rising edge of the optical input signal. Output is a CMOS tri-state driver, which swings between ground and V <sub>CC</sub> . Receiver echoes transmitter output.	O	Low
5	SD	Shutdown. Logic low at this input enables the receiver, enables the transmitter, and un-tri-states the receiver output. It must be driven high for shutting down the transceiver.	I	High
6	V <sub>CC</sub>	Power supply, 2.4 V to 5.5 V. This pin provides power for the receiver and transmitter drive section. Connect V <sub>CC1</sub> via an optional filter.		
7	GND	Ground		

**PINOUT**

TFBS4650, bottom view  
weight 0.04 g

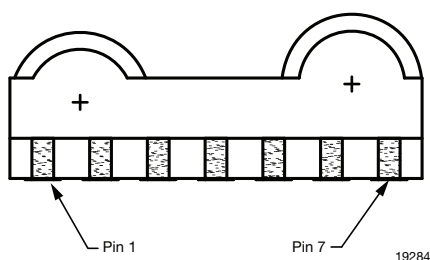



ABSOLUTE MAXIMUM RATINGS						
PARAMETER	TEST CONDITIONS	SYMBOL	MIN.	TYP.	MAX.	UNIT
Supply voltage range, transceiver	$-0.3\text{ V} < V_{CC2} < 6\text{ V}$	$V_{CC1}$	-0.5	-	+6	V
Supply voltage range, transmitter	$-0.5\text{ V} < V_{CC1} < 6\text{ V}$	$V_{CC2}$	-0.5	-	+6	V
RXD output voltage	$-0.5\text{ V} < V_{CC1} < 6\text{ V}$	$V_{RXD}$	-0.5	-	$V_{CC1} + 0.5$	V
Voltage at all inputs	Note: $V_{in} \geq V_{CC1}$ is allowed	$V_{IN}$	-0.5	-	+6	V
Input current	For all pins, except IRED anode pin		-	-	10	mA
Output sinking current			-	-	25	mA
Power dissipation		$P_D$	-	-	250	mW
Junction temperature		$T_J$	-	-	125	°C
Ambient temperature range (operating)		$T_{amb}$	-25	-	+85	°C
Storage temperature range		$T_{stg}$	-25	-	+85	°C
Soldering temperature	See recommended solder profile		-	-	260	°C
Average output current, pin 1		$I_{IRED(DC)}$	-	-	85	mA
Repetitive pulsed output current, pin 1 to pin 2	$t < 90\ \mu\text{s}$ , $t_{on} < 20\ \%$	$I_{IRED(RP)}$	-	-	430	mA
ESD protection	JESD22-A114	$V_{ESD}$	2	-	-	kV
Latchup	JESD78		$ \pm 100 $	-	-	mA
Thermal resistance junction-to-ambient	JESD51	$R_{thJA}$	-	300	-	K/W

**Note**

- Reference point ground (pin 8) unless otherwise noted. Typical values are for DESIGN AID ONLY, not guaranteed nor subject to production testing.

EYE SAFETY INFORMATION	
STANDARD	CLASSIFICATION
IEC/EN 60825-1 (2007-03), DIN EN 60825-1 (2008-05) "SAFETY OF LASER PRODUCTS - Part 1: equipment classification and requirements", simplified method	Class 1
IEC 62471 (2006), CIE S009 (2002) "Photobiological Safety of Lamps and Lamp Systems"	Exempt
DIRECTIVE 2006/25/EC OF THE EUROPEAN PARLIAMENT AND OF THE COUNCIL of 5 <sup>th</sup> April 2006 on the minimum health and safety requirements regarding the exposure of workers to risks arising from physical agents (artificial optical radiation) (19 <sup>th</sup> individual directive within the meaning of article 16(1) of directive 89/391/EEC)	Exempt

**Note**

- Vishay transceivers operating inside the absolute maximum ratings are classified as eye safe according the above table



<b>ELECTRICAL CHARACTERISTICS</b> ( $T_{amb} = 25\text{ }^{\circ}\text{C}$ , $V_{CC} = 2.4\text{ V to }5.5\text{ V}$ unless otherwise noted)						
PARAMETER	TEST CONDITIONS	SYMBOL	MIN.	TYP.	MAX.	UNIT
<b>TRANSCEIVER</b>						
Supply voltage range		$V_{CC}$	2.4	-	5.5	V
Dynamic supply current						
Idle supply current at $V_{CC1}$ (receive mode, no signal)	SD = low, $T_{amb} = -25\text{ }^{\circ}\text{C to }+85\text{ }^{\circ}\text{C}$ independent of ambient light, $V_{CC1} = V_{CC2} = 2.4\text{ V to }5.5\text{ V}$	$I_{CC1}$	40	70	110	$\mu\text{A}$
Average dynamic supply current, transmitting	$I_{RED} = 300\text{ mA}$ , 20 % duty cycle	$I_{CC1}$	-	0.6	2	mA
Standby (SD) <sup>(1)</sup> supply current	SD = high, $T_{amb} = -25\text{ }^{\circ}\text{C to }+85\text{ }^{\circ}\text{C}$ independent of ambient light	$I_{SD}$	-	0.01	1	$\mu\text{A}$
Input voltage low (TXD, SD)		$V_{IL}$	-0.5	-	0.5	V
Input voltage high	$V_{CC} = 2.4\text{ V to }5.5\text{ V}$	$V_{IH}$	$V_{CC} - 0.5$	-	6	V
Input voltage threshold SD	$V_{CC} = 2.4\text{ V to }5.5\text{ V}$		0.9	1.35	1.8	V
Output voltage low	$V_{CC} = 2.4\text{ V to }5.5\text{ V}$ $C_{LOAD} = 15\text{ pF}$	$V_{OL}$	-	-	$V_{CC} \times 0.15$	V
Output voltage high	$I_{OH} = 200\text{ }\mu\text{A}$	$V_{OH}$	$V_{CC} \times 0.8$	-	-	V
RXD to $V_{CC}$ pull-up impedance	SD = $V_{CC}$ $V_{CC} = 2.4\text{ V to }5\text{ V}$	$R_{RXD}$	400	500	600	k $\Omega$
Input capacitance (TXD, SD)		$C_I$	-	-	6	pF

**Note**

- Typical values are for design aid only, not guaranteed nor subject to production testing



<b>OPTOELECTRONIC CHARACTERISTICS</b> ( $T_{amb} = 25\text{ }^{\circ}\text{C}$ , $V_{CC} = 2.4\text{ V to } 5.5\text{ V}$ unless otherwise noted)						
PARAMETER	TEST CONDITIONS	SYMBOL	MIN.	TYP.	MAX.	UNIT
<b>RECEIVER</b>						
Sensitivity: minimum irradiance $E_e$ in angular range <sup>(1)(2)</sup>	9.6 kbit/s to 115.2 kbit/s $\lambda = 850\text{ nm to } 900\text{ nm}$	$E_e$	-	40	81	mW/m <sup>2</sup>
Maximum irradiance $E_e$ in angular range	$\lambda = 850\text{ nm to } 900\text{ nm}$	$E_e$	2	-	-	kW/m <sup>2</sup>
No receiver output input irradiance <sup>(3)</sup>	According to IrDA IrPHY 1.4, appendix A1, fluorescent light specification	$E_e$	4	-	-	mW/m <sup>2</sup>
Rise time of output signal	10 % to 90 %, $C_L = 15\text{ pF}$	$t_{r(RXD)}$	20	-	100	ns
Fall time of output signal	90 % to 10 %, $C_L = 15\text{ pF}$	$t_{f(RXD)}$	20	-	100	ns
RXD pulse width of output signal, 50 % <sup>(4)</sup>	Input pulse width 1.63 $\mu\text{s}$	$t_{PW}$	1.7	2	2.9	$\mu\text{s}$
Receiver start up time	Power on delay		-	100	150	$\mu\text{s}$
Latency		$t_L$	-	50	200	$\mu\text{s}$
<b>TRANSMITTER</b>						
IRED operating current limitation	No external resistor for current limitation <sup>(4)</sup>	$I_D$	200	300	430	mA
Forward voltage of built-in IRED	$I_f = 300\text{ mA}$	$V_f$	1.4	1.8	1.9	V
Output leakage IRED current	TXD = 0 V, $0 < V_{CC1} < 5.5\text{ V}$	$I_{IRED}$	-1	0.01	1	$\mu\text{A}$
Output radiant intensity	$\alpha = 0^{\circ}, 15^{\circ}$ , TXD = high, SD = low	$I_e$	40	250	400	mW/sr
	$V_{CC1} = 5\text{ V}$ , $\alpha = 0^{\circ}, 15^{\circ}$ , TXD = low or SD = high (receiver is inactive as long as SD = high)	$I_e$	-	-	0.04	mW/sr
Output radiant intensity, angle of half intensity		$\alpha$	-	$\pm 30$	-	$^{\circ}$
Peak - emission wavelength <sup>(5)</sup>		$\lambda_p$	870	-	910	nm
Spectral bandwidth		$\Delta\lambda$	-	45	-	nm
Optical rise time, fall time		$t_{ropt}, t_{fopt}$	10	50	300	ns
Optical output pulse duration	Input pulse width $1.6 < t_{TXD} < 23\text{ }\mu\text{s}$	$t_{opt}$	$t_{TXD} - 0.15$	-	$t_{TXD} + 0.15$	$\mu\text{s}$
	Input pulse width $t_{TXD} \geq 23\text{ }\mu\text{s}$	$t_{opt}$	23	50	100	$\mu\text{s}$
Optical overshoot			-	-	25	%

**Notes**

- Typical values are for design aid only, not guaranteed nor subject to production testing
- (1) This parameter reflects the backlight test of the IrDA physical layer specification to guarantee immunity against light from fluorescent lamps.
- (2) IrDA sensitivity definition: minimum irradiance  $E_e$  in angular range, power per unit area. The receiver must meet the BER specification while the source is operating at the minimum intensity in angular range into the minimum half-angular range at the maximum link length
- (3) Maximum irradiance  $E_e$  in angular range, power per unit area. The optical delivered to the detector by a source operating at the maximum intensity in angular range at minimum link length must not cause receiver overdrive distortion and possible related link errors. If placed at the active output interface reference plane of the transmitter, the receiver must meet its bit error ratio (BER) specification. For more definitions see the document "Symbols and Terminology" on the Vishay website
- (4) RXD output is edge triggered by the rising edge of the optical input signal. The output pulse duration is independent of the input pulse duration
- (5) The radiant intensity can be adjusted by the external current limiting resistor to adapt the intensity to the desired value. The given value is for minimum current consumption. This transceiver can be adapted to > 50 cm operation by increasing the current to > 200 mA, e.g. operating the transceiver without current control resistor (i.e.  $R1 = 0\text{ }\Omega$ ) and using the internal current control



**RECOMMENDED CIRCUIT DIAGRAM**

Operated with a clean low impedance power supply the TFBS4650 needs no additional external components. However, depending on the entire system design and board layout, additional components may be required (see Fig. 1).

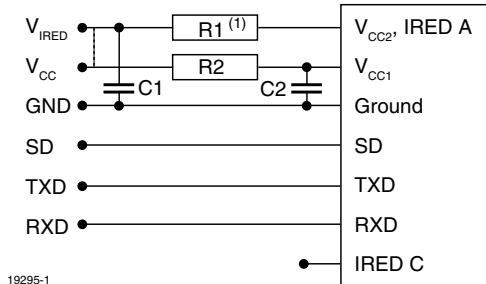

Fig. 1 - Recommended Application Circuit

**Note**

(1) R1 is optional when reduced intensity is used

The capacitor C1 is buffering the supply voltage and eliminates the inductance of the power supply line. This one should be a tantalum or other fast capacitor to guarantee the fast rise time of the IRED current. The resistor R1 is the current limiting resistor, which may be used to reduce the operating current to levels below the specified controlled values for saving battery power.

Vishay’s transceivers integrate a sensitive receiver and a built-in power driver. The combination of both needs a careful circuit board layout. The use of thin, long, resistive and inductive wiring should be avoided. The shutdown input must be grounded for normal operation, also when the shutdown function is not used.

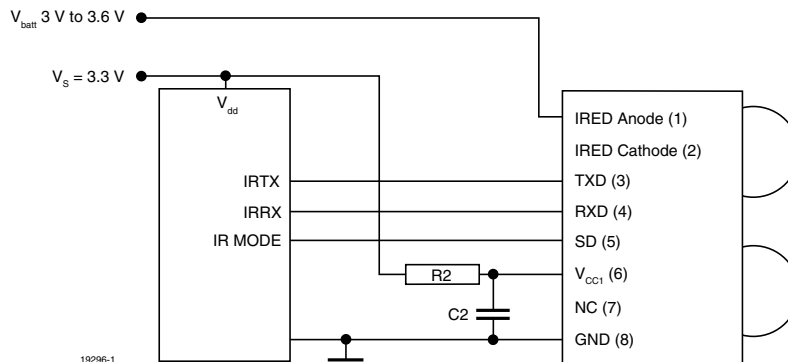

Fig. 2 - Typical Application Circuit

Fig. 2 shows an example of a typical application for to work with a separate supply voltage  $V_S$  and using the transceiver with the IRED Anode connected to the unregulated battery  $V_{batt}$ . This method reduces the peak load of the regulated

**TABLE 1 - RECOMMENDED APPLICATION CIRCUIT COMPONENTS**

COMPONENT	RECOMMENDED VALUE
C1	4.7 $\mu$ F
C2	0.1 $\mu$ F, ceramic
R1	Depends on current to be adjusted
R2	47 $\Omega$

The inputs (TXD, SD) and the output RXD should be directly connected (DC - coupled) to the I/O circuit. The capacitor C2 combined with the resistor R2 is the low pass filter for smoothing the supply voltage. R2, C1 and C2 are optional and dependent on the quality of the supply voltages  $V_{CC1}$  and injected noise. An unstable power supply with dropping voltage during transmission may reduce the sensitivity (and transmission range) of the transceiver.

The placement of these parts is critical. It is strongly recommended to position C2 as close as possible to the transceiver pins.

When extended wiring is used as in bench tests the inductance of the power supply can cause dynamically a voltage drop at  $V_{CC2}$ . Often some power supplies are not able to follow the fast current rise time. In that case another 4.7  $\mu$ F (type, see table under C1) at  $V_{CC2}$  will be helpful.

Under extreme EMI conditions as placing an RF-transmitter antenna on top of the transceiver, we recommend to protect all inputs by a low-pass filter, as a minimum a 12 pF capacitor, especially at the RXD port.

power supply and saves therefore costs. Alternatively all supplies can also be tied to only one voltage source. R1 and C1 are not used in this case and are depending on the circuit design in most cases not necessary.



**I/O AND SOFTWARE**

In the description, already different I/Os are mentioned. Different combinations are tested and the function verified with the special drivers available from the I/O suppliers. In special cases refer to the I/O manual, the Vishay application notes, or contact directly Vishay Sales, Marketing or Application.

For operating at RS232 ports we recommend to use an encoder / decoder-module.

**Note**

- TFBS4650 echoes the TXD signal at the RXD output during transmission. For communication this signal is to be correctly ignored by the controller or the software. The echo signal is implemented for test purposes in mass production

TABLE 2 - TRUTH TABLE					
INPUTS			OUTPUTS		REMARK
SD	TXD	OPTICAL INPUT IRRADIANCE mW/m <sup>2</sup>	RXD	TRANSMITTER	OPERATION
High > 1 ms	x	x	Weakly pulled (500 kΩ) to V <sub>CC1</sub>	0	Shutdown
Low	High	x	Low (active)	I <sub>e</sub>	Transmitting
Low	High > 100 μs	x	High inactive	0	Protection is active
Low	Low	< 4	High inactive	0	Ignoring low signals below the IrDA defined threshold for noise immunity
Low	Low	> min. detection threshold irradiance < max. detection threshold irradiance	Low (active)	0	Response to an IrDA compliant optical input signal
Low	Low	> max. detection threshold irradiance	Undefined	0	Overload conditions can cause unexpected outputs

**ASSEMBLY INSTRUCTIONS**

**Reflow Soldering**

- Reflow soldering must be done within 72 h while stored under a max. temperature of 30 °C, 60 % RH after opening the dry pack envelope
- Set the furnace temperatures for pre-heating and heating in accordance with the reflow temperature profile as shown in the diagram. Exercise extreme care to keep the maximum temperature below 260 °C. The temperature shown in the profile means the temperature at the device surface. Since there is a temperature difference between the component and the circuit board, it should be verified that the temperature of the device is accurately being measured
- Handling after reflow should be done only after the work surface has been cooled off

**Manual Soldering**

- Use a soldering iron of 25 W or less. Adjust the temperature of the soldering iron below 300 °C
- Finish soldering within 3 s
- Handle products only after the temperature has cooled off

**VISHAY LEAD (Pb)-FREE REFLOW SOLDER PROFILE**

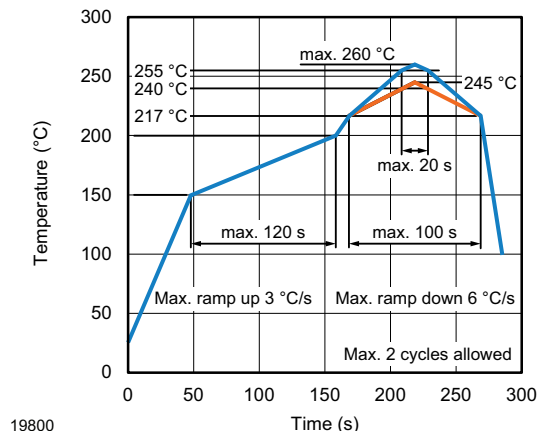



**PACKAGE DIMENSIONS** in millimeters

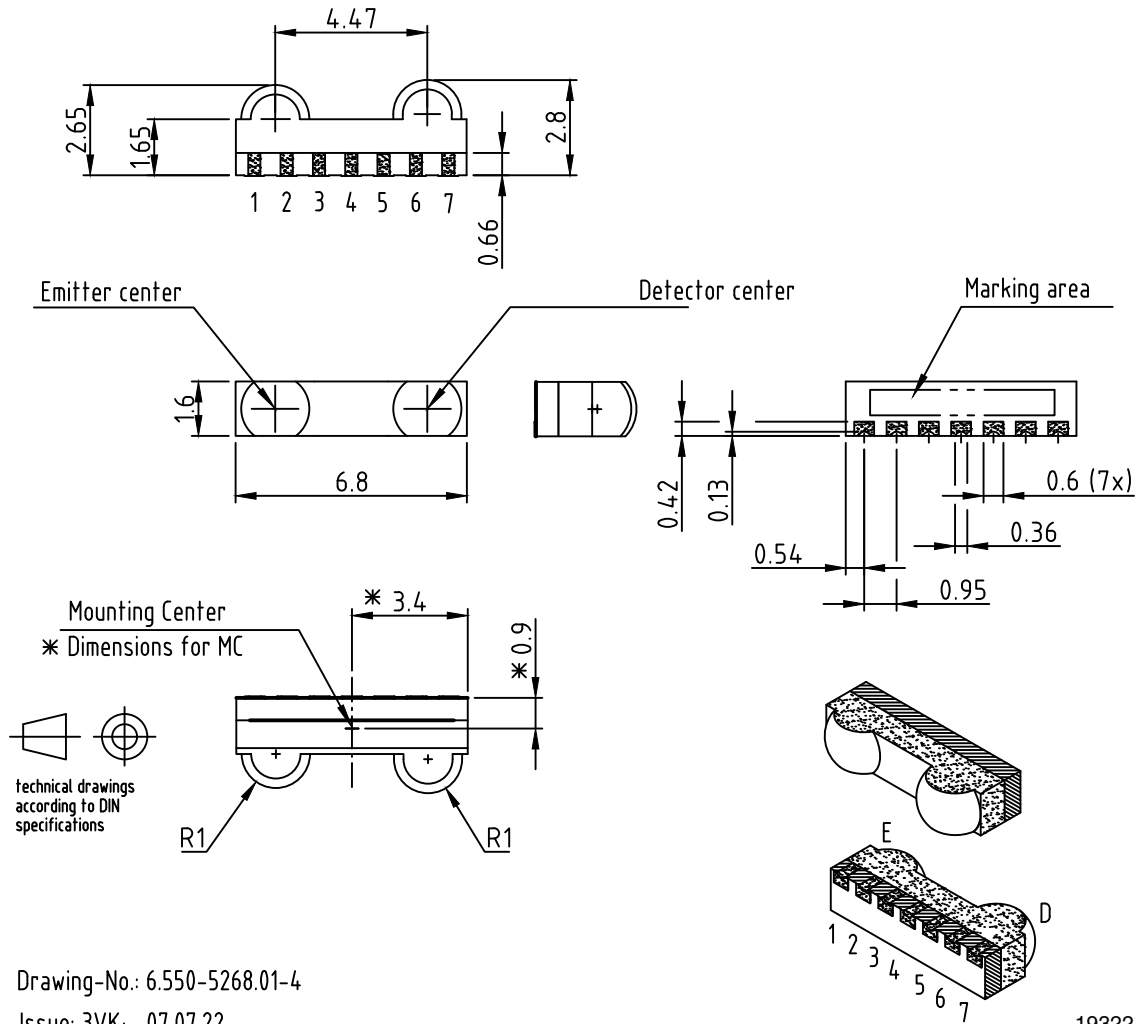

Fig. 3 - TFBS4650 Mechanical Dimensions, Tolerance  $\pm 0.2$  mm, if not Otherwise Mentioned

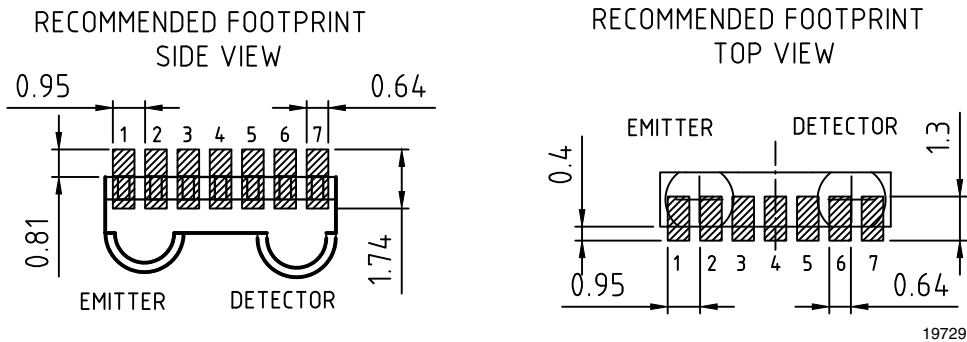
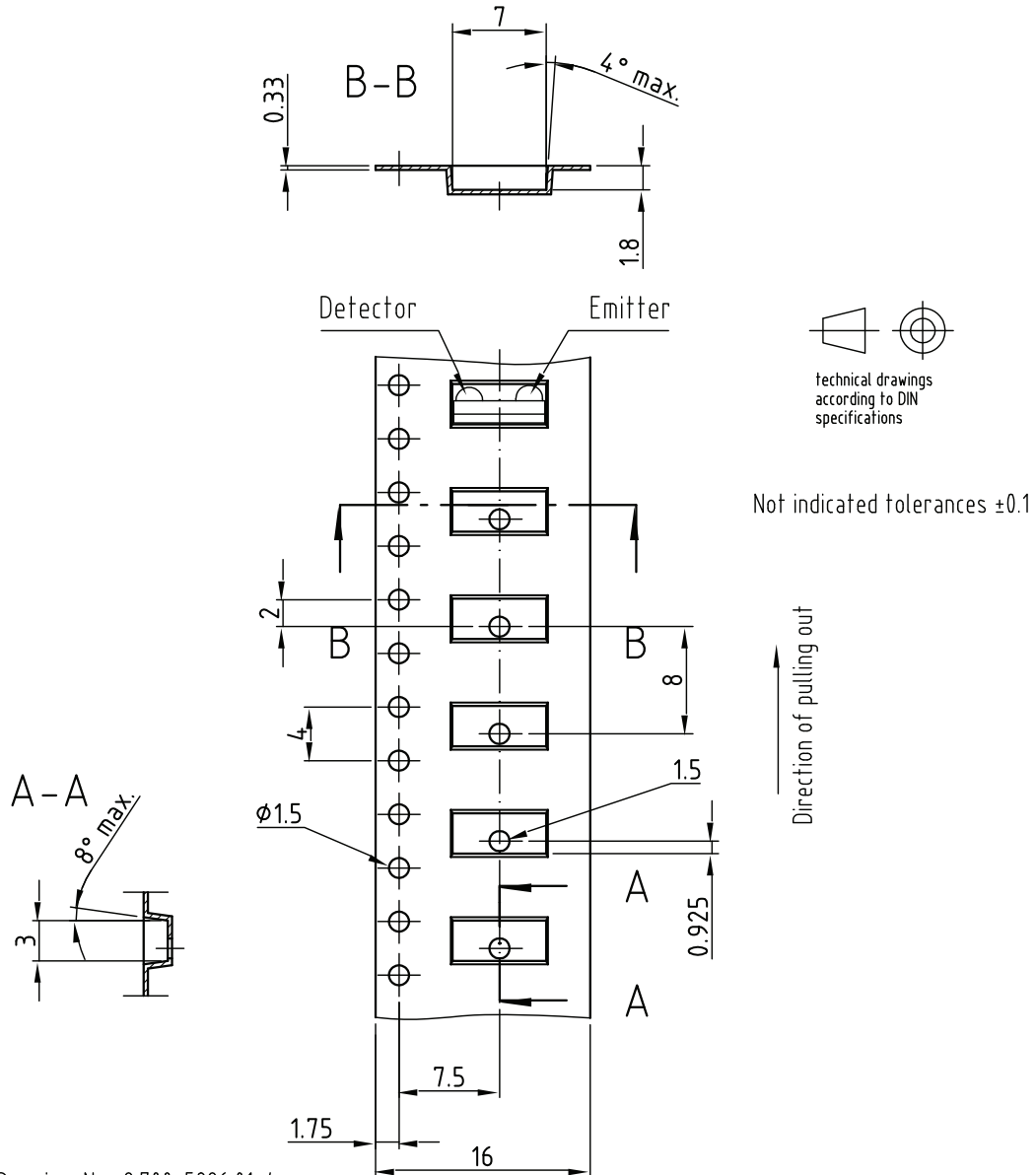

Fig. 4 - TFBS4650 Soldering Footprint, Tolerance  $\pm 0.2$  mm, if not Otherwise Mentioned





TAPE DIMENSIONS FOR TR1 AND TR3 in millimeters



Drawing-No.: 9.700-5296.01-4  
 Issue: 1; 08.12.04  
 19783



TAPE DIMENSIONS FOR TT3 in millimeters

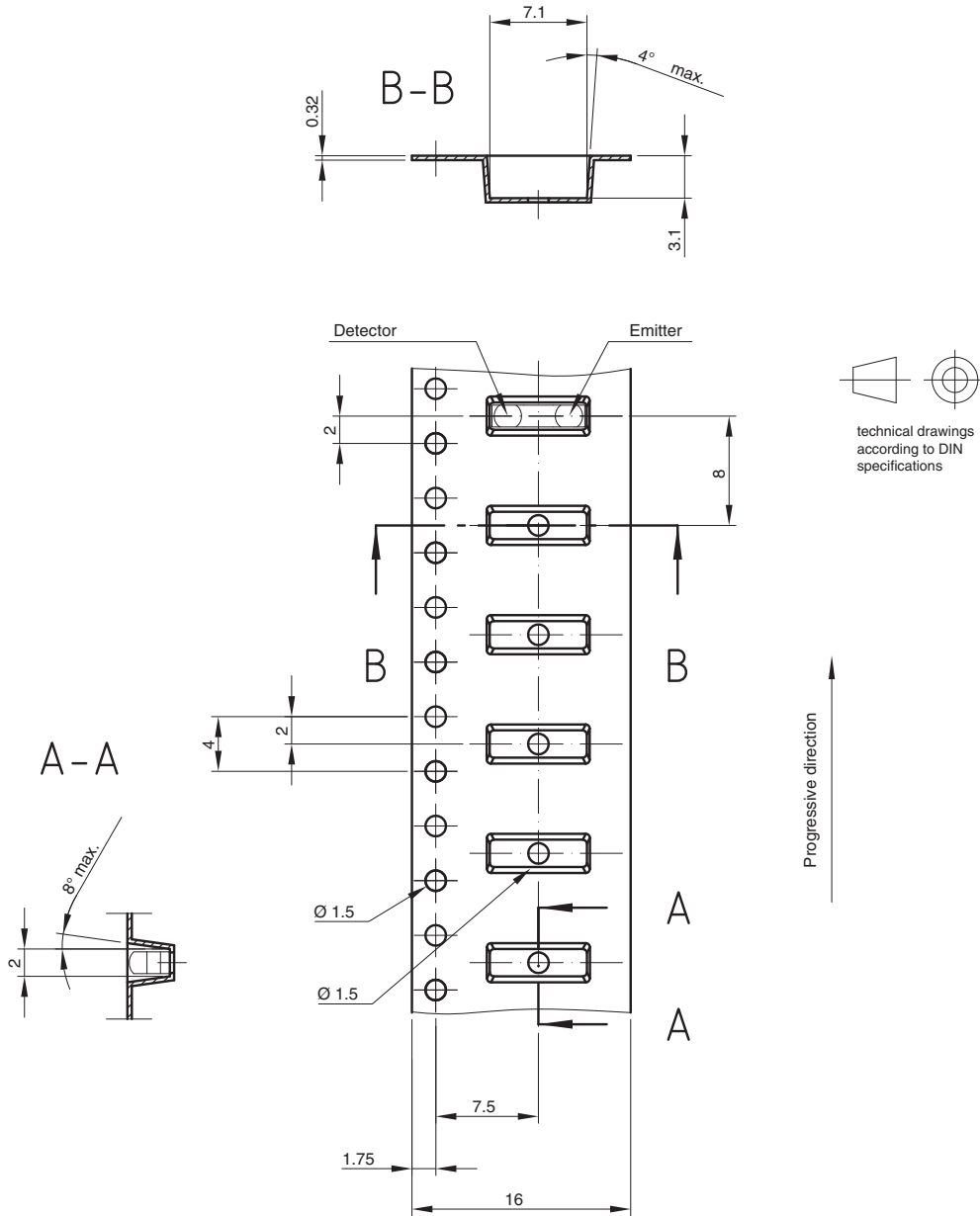

Drawing-No.: 9.700-5340.01-4  
 Issue: 1; 15.01.09  
 21663



**REEL DIMENSIONS** in millimeters

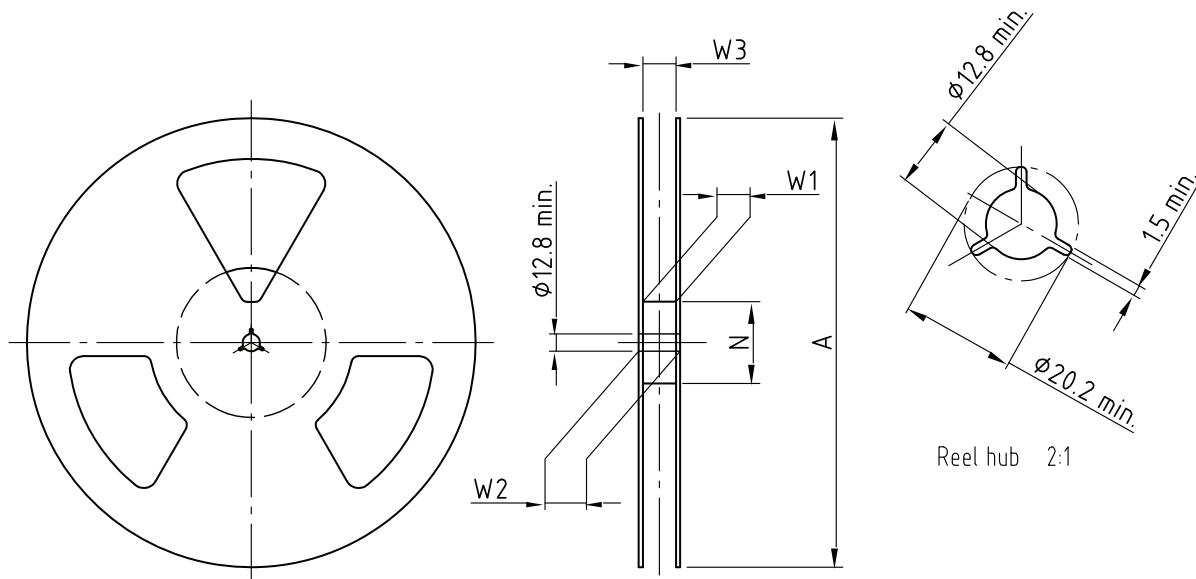

Drawing-No.: 9.800-5090.01-4  
Issue: 1; 29.11.05  
14017

Form of the leave open of the wheel is supplier specific.

Dimension acc. to IEC EN 60 286-3

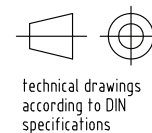

TAPING VARIANT	TAPE WIDTH (mm)	A MAX. (mm)	N (mm)	W <sub>1</sub> MIN. (mm)	W <sub>2</sub> MAX. (mm)	W <sub>3</sub> MIN. (mm)	W <sub>3</sub> MAX. (mm)
TT1 / TR1	16	180	60	16.4	22.4	15.9	19.4
TT3 / TR3	16	330	50	16.4	22.4	15.9	19.4

**LEADER AND TRAILER DIMENSIONS** in millimeters

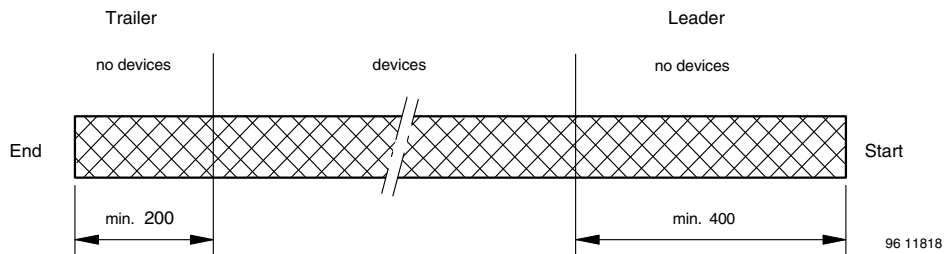

**COVER TAPE PEEL STRENGTH**

According to DIN EN 60286-3  
0.1 N to 1.3 N  
300 ± 10 mm/min.  
165° to 180° peel angle

**LABEL**

**Standard bar code labels for finished goods**

The standard bar code labels are product labels and used for identification of goods. The finished goods are packed in final packing area. The standard packing units are labeled with standard bar code labels before transported as finished goods to warehouses. The labels are on each packing unit and contain Vishay Semiconductor GmbH specific data.



**DRY PACKING**

The reel is packed in an anti-humidity bag to protect the devices from absorbing moisture during transportation and storage.

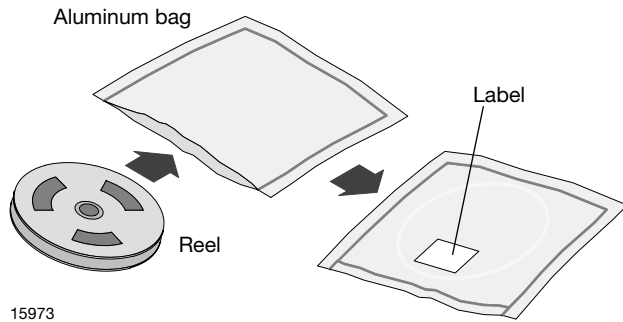

**FINAL PACKING**

The sealed reel is packed into a cardboard box.

**RECOMMENDED METHOD OF STORAGE**

Dry box storage is recommended as soon as the aluminum bag has been opened to prevent moisture absorption. The following conditions should be observed, if dry boxes are not available:

- Storage temperature 10 °C to 30 °C
- Storage humidity ≤ 60 % RH max.

After more than 72 h under these conditions moisture content will be too high for reflow soldering.

In case of moisture absorption, the devices will recover to the former condition by drying under the following condition:  
 192 h at 40 °C + 5 °C / - 0 °C and < 5 % RH (dry air / nitrogen) or  
 96 h at 60 °C + 5 °C and < 5 % RH for all device containers or  
 24 h at 125 °C + 5 °C not suitable for reel or tubes.

An EIA JEDEC® standard J-STD-020 level 4 label is included on all dry bags.

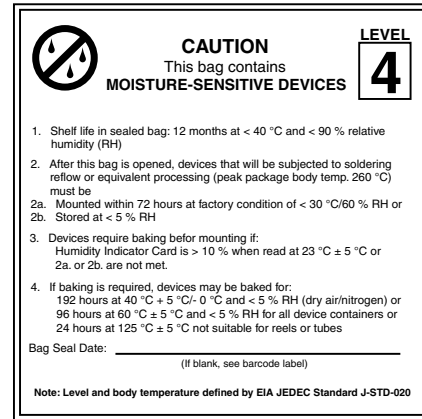

EIA JEDEC standard J-STD-020 level 4 label is included on all dry bags

**OUTER PACKAGING**

The sealed reel is packed into a pizza box.

CARTON BOX DIMENSIONS in millimeters				
<p>Thickness</p> <p>Width</p> <p>Length</p> <p>22127</p>				
ORDER CODE	BOXING	THICKNESS	WIDTH	LENGTH
TT3 / TR3	Pizza box (taping in reels)	50	340	340
TT1 / TR1	Pizza box (taping in reels)	32	190	190



VISHAY SEMICONDUCTOR GmbH STANDARD BAR CODE PRODUCT LABEL (finished goods)		
PLAIN WRITING	ABBREVIATION	LENGTH
Item-description	-	18
Item-number	INO	8
Selection-code	SEL	3
LOT-/serial-number	BATCH	10
Data-code	COD	3 (YWW)
Plant-code	PTC	2
Quantity	QTY	8
Accepted by	ACC	-
Packed by	PCK	-
Mixed code indicator	MIXED CODE	-
Origin	xxxxxxx+	Company logo
Long bar code top	Type	Length
Item-number	N	8
Plant-code	N	2
Sequence-number	X	3
Quantity	N	8
Total length	-	21
Short bar code bottom	Type	Length
Selection-code	X	3
Data-code	N	3
Batch-number	X	10
Filter	-	1
Total length	-	17

**ESD PRECAUTION**

Proper storage and handling procedures should be followed to prevent ESD damage to the devices especially when they are removed from the antistatic shielding bag. Electrostatic sensitive devices warning labels are on the packaging.

**VISHAY SEMICONDUCTORS STANDARD BAR CODE LABELS**

The Vishay Semiconductors standard bar code labels are printed at final packing areas. The labels are on each packing unit and contain Vishay Semiconductors specific data.





## **Disclaimer**

ALL PRODUCT, PRODUCT SPECIFICATIONS AND DATA ARE SUBJECT TO CHANGE WITHOUT NOTICE TO IMPROVE RELIABILITY, FUNCTION OR DESIGN OR OTHERWISE.

Vishay Intertechnology, Inc., its affiliates, agents, and employees, and all persons acting on its or their behalf (collectively, "Vishay"), disclaim any and all liability for any errors, inaccuracies or incompleteness contained in any datasheet or in any other disclosure relating to any product.

Vishay makes no warranty, representation or guarantee regarding the suitability of the products for any particular purpose or the continuing production of any product. To the maximum extent permitted by applicable law, Vishay disclaims (i) any and all liability arising out of the application or use of any product, (ii) any and all liability, including without limitation special, consequential or incidental damages, and (iii) any and all implied warranties, including warranties of fitness for particular purpose, non-infringement and merchantability.

Statements regarding the suitability of products for certain types of applications are based on Vishay's knowledge of typical requirements that are often placed on Vishay products in generic applications. Such statements are not binding statements about the suitability of products for a particular application. It is the customer's responsibility to validate that a particular product with the properties described in the product specification is suitable for use in a particular application. Parameters provided in datasheets and / or specifications may vary in different applications and performance may vary over time. All operating parameters, including typical parameters, must be validated for each customer application by the customer's technical experts. Product specifications do not expand or otherwise modify Vishay's terms and conditions of purchase, including but not limited to the warranty expressed therein.

Hyperlinks included in this datasheet may direct users to third-party websites. These links are provided as a convenience and for informational purposes only. Inclusion of these hyperlinks does not constitute an endorsement or an approval by Vishay of any of the products, services or opinions of the corporation, organization or individual associated with the third-party website. Vishay disclaims any and all liability and bears no responsibility for the accuracy, legality or content of the third-party website or for that of subsequent links.

Except as expressly indicated in writing, Vishay products are not designed for use in medical, life-saving, or life-sustaining applications or for any other application in which the failure of the Vishay product could result in personal injury or death. Customers using or selling Vishay products not expressly indicated for use in such applications do so at their own risk. Please contact authorized Vishay personnel to obtain written terms and conditions regarding products designed for such applications.

No license, express or implied, by estoppel or otherwise, to any intellectual property rights is granted by this document or by any conduct of Vishay. Product names and markings noted herein may be trademarks of their respective owners.