

**SPECIFICATION** **CST121R2GT2B2C**

**PACKAGE OUTLINES**

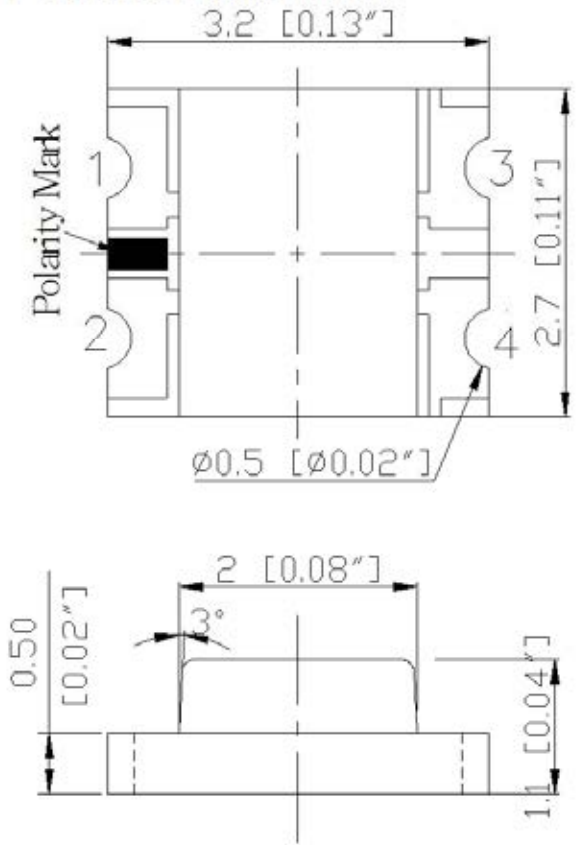

**RECOMMENDED PAD LAYOUT**

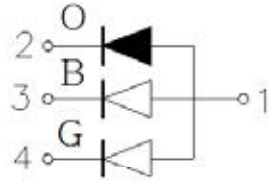
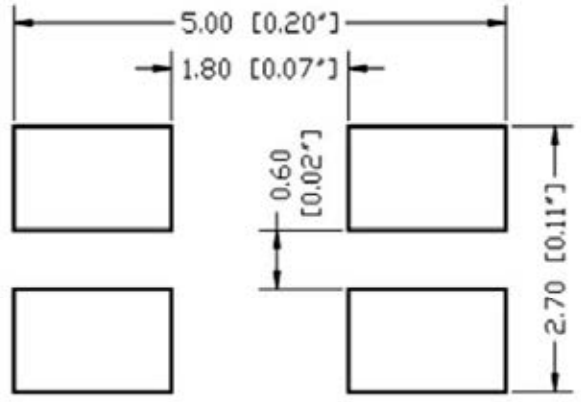

- Notes:
1. All dimensions are in millimeters (inches).
  2. Tolerance is  $\pm 0.25\text{mm}$  (0.01") unless otherwise noted.
  3. Specifications are subject to change without notice.

Part Number	Chip Material	Color of Emission	Lens Type	Viewing Angle
CST121R2GT2B2C	InGaAlP	Red	Water Clear	140°
	InGaN	Green	Water Clear	140°
	InGaN	Blue	Water Clear	140°



ChromeLED Corp. reserves the right to make changes at any time in order to supply the best product possible. The most current version of this document will always be available at: [www.chromeled.com](http://www.chromeled.com)

**ABSOLUTE MAXIMUM RATINGS**
**(TA=25°C)**

Parameter	Symbol	Max Rating		Unit
		Blue/ Green	Red	
Forward Current	IF	30	30	mA
Reverse Voltage	VR	5	5	V
Power Dissipation	Pd	111	75	mW
Operating Temperature Range	TOP	-40~+85		°C
Storage Temperature Range	TSTG	-40~+85		°C
Peak Pulsing Current (tp ≤ 10 μs, duty cycle = 0.005)	IFP	125	125	mA

**OPTICAL-ELECTRICAL CHARACTERISTICS**
**(TA=25°C)**

Parameter	Symbol	Test Condition	Color	Value			Unit
				Min	Typ	Max	
Luminous Intensity	Iv	IF = 20mA	Red	100	180	-	mcd
			Green	320	600	-	
			Blue	50	95	-	
Forward Voltage	VF	IF = 20mA	Red	-	2.0	2.5	V
			Green	-	3.1	3.7	
			Blue	-	3.1	3.7	
Viewing Angle at 50% Iv	2θ1/2	IF = 10mA	-	-	140	-	Deg
Dominant Wavelength	λD	IF = 20mA	Red	-	630	-	nm
			Green	-	520	-	
			Blue	-	460	-	

\*Tolerance of viewing angle: -10 / +5 deg.



ChromeLED Corp. reserves the right to make changes at any time in order to supply the best product possible. The most current version of this document will always be available at: [www.chromeled.com](http://www.chromeled.com)

TYPICAL ELECTRO-OPTICAL CHARACTERISTIC CURVES (RED)

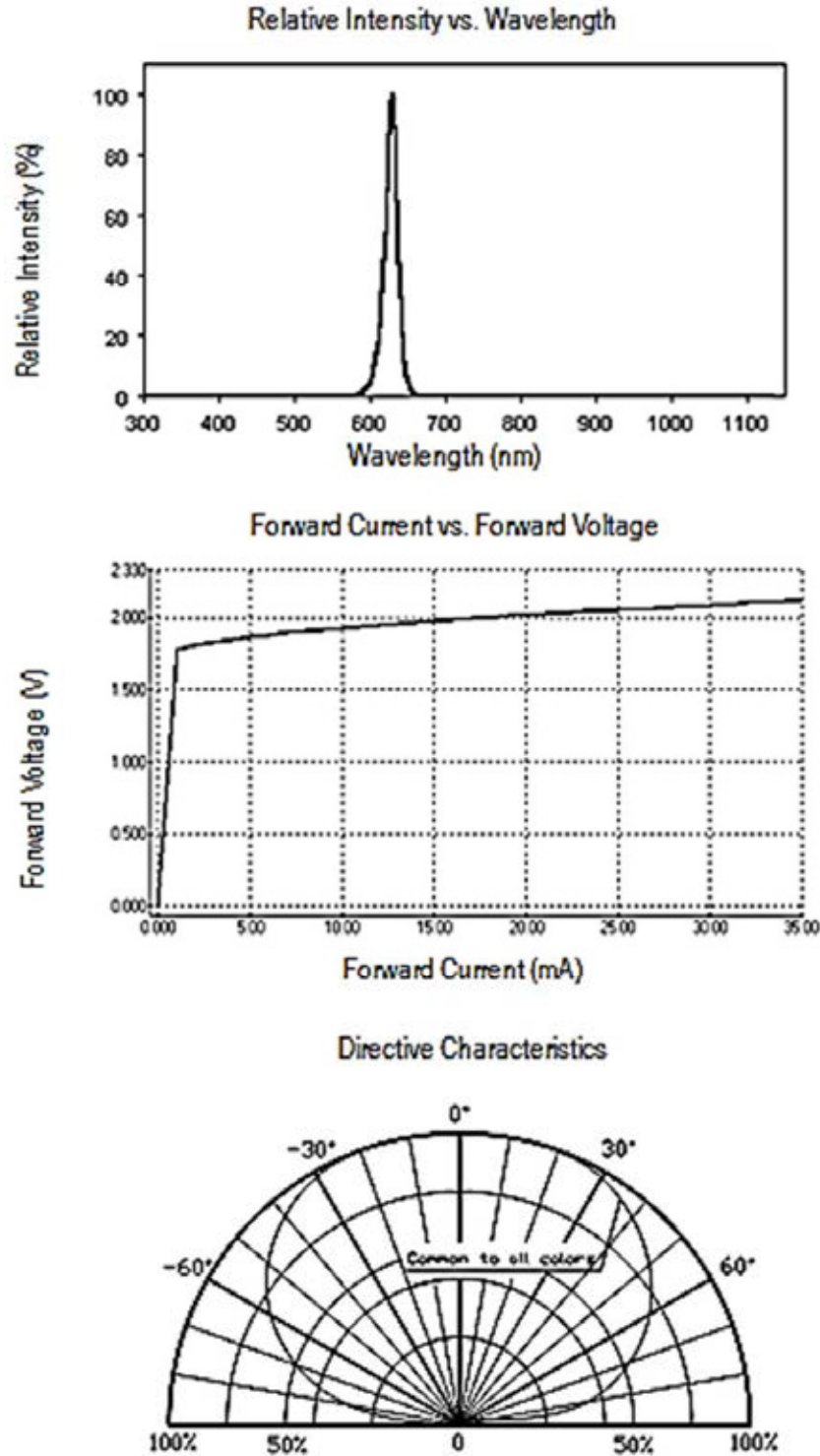

ChromeLED Corp. reserves the right to make changes at any time in order to supply the best product possible. The most current version of this document will always be available at: [www.chromeled.com](http://www.chromeled.com)

**TYPICAL ELECTRO-OPTICAL CHARACTERISTIC CURVES (GREEN)**

Relative Intensity vs. Wavelength

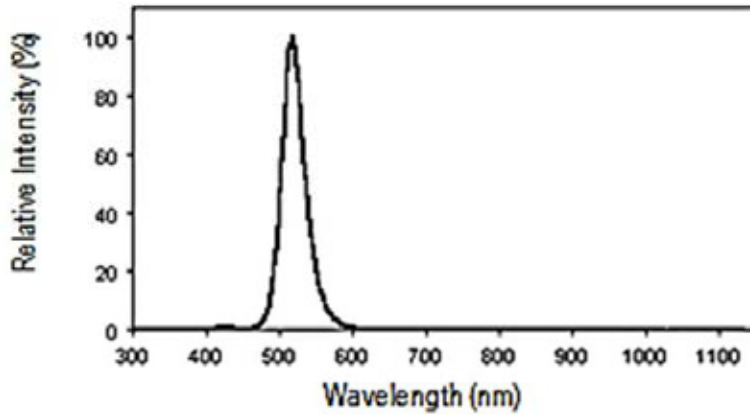

Forward Current vs. Forward Voltage

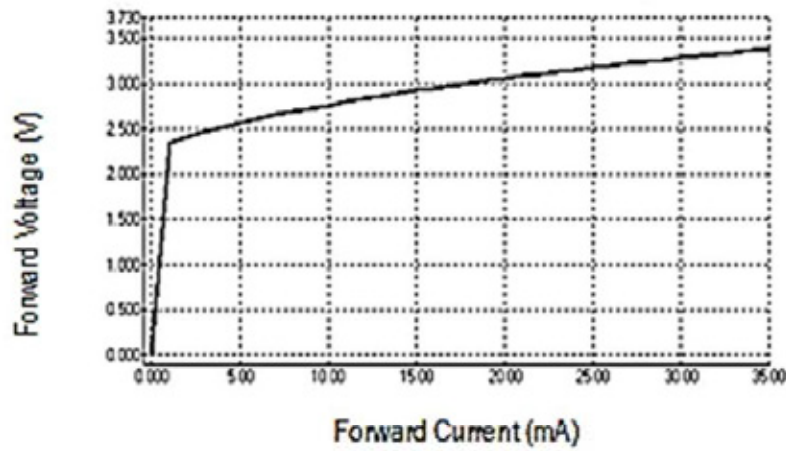

Directive Characteristics

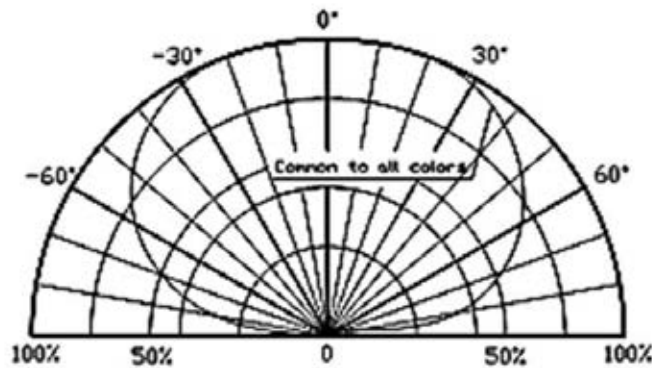

ChromeLED Corp. reserves the right to make changes at any time in order to supply the best product possible. The most current version of this document will always be available at: [www.chromeled.com](http://www.chromeled.com)

**TYPICAL ELECTRO-OPTICAL CHARACTERISTIC CURVES (BLUE)**

Relative Intensity vs. Wavelength

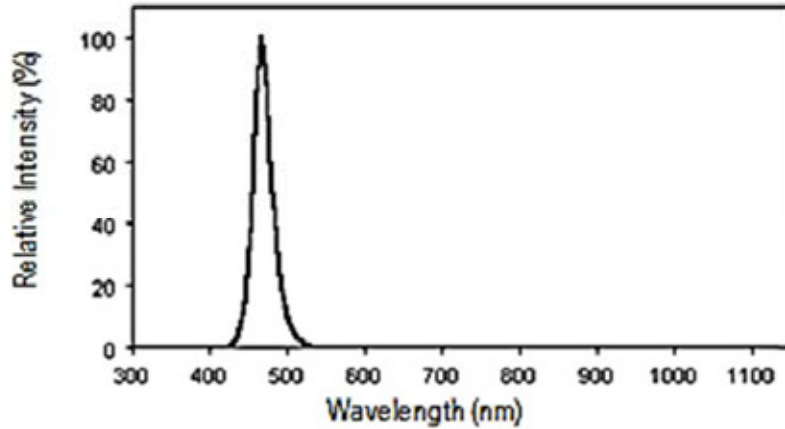

Forward Current vs. Forward Voltage

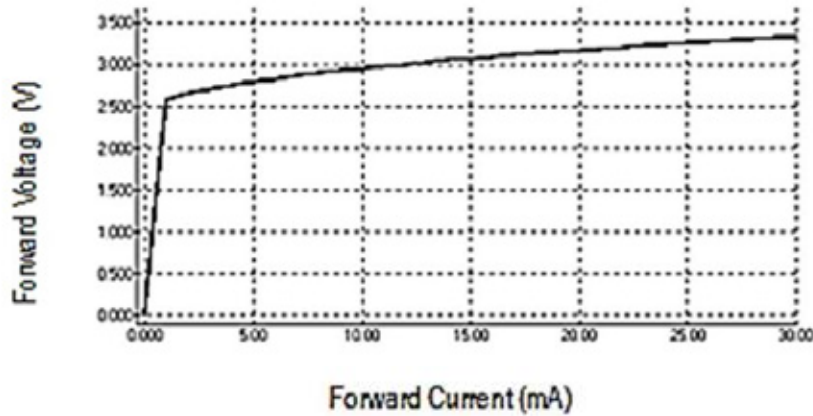

Directive Characteristics

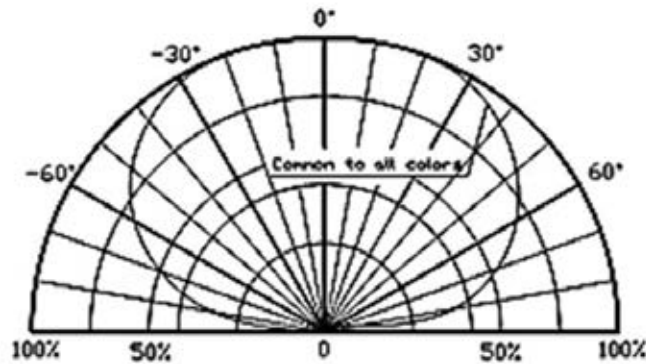

ChromeLED Corp. reserves the right to make changes at any time in order to supply the best product possible. The most current version of this document will always be available at: [www.chromeled.com](http://www.chromeled.com)

## SOLDERING CONDITIONS

### REFLOW PROFILE

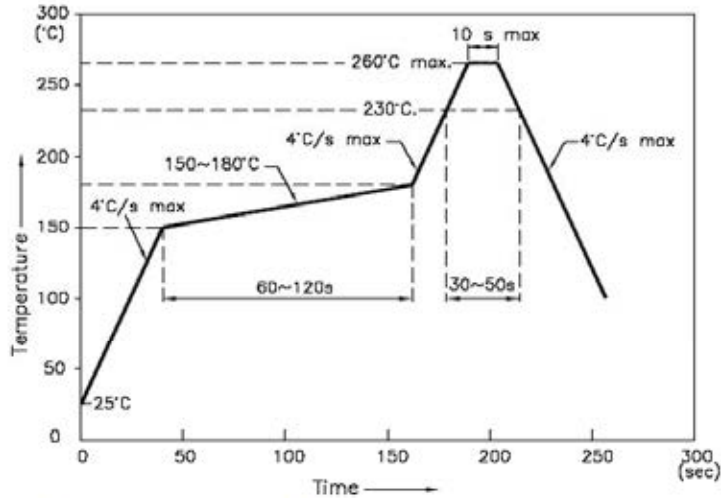

1. We recommend the reflow temperature 245°C (±5°C). Customer must finish rework within 5 seconds under 260°C.
2. The head of iron cannot touch copper foil
3. Twin head type is preferred
  - Soldering iron
    - Basic spec is ≤ 5sec when 260°C. If temperature is higher, time should be shorter (+10°C → -1sec). Power dissipation of iron should be smaller than 20W, and temperatures should be controllable. Surface temperature of the device should be under 230°C.

#### Rework

1. Customer must finish rework within 5 sec under 260°C.
2. The head of iron cannot touch copper foil
3. Twin-head type is preferred

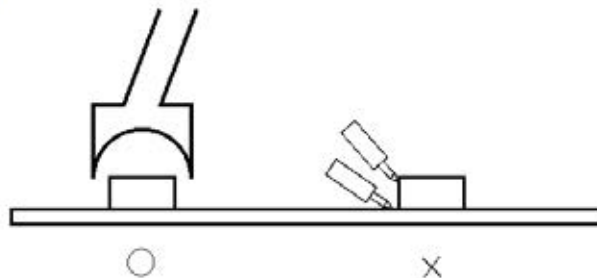

ChromeLED Corp. reserves the right to make changes at any time in order to supply the best product possible. The most current version of this document will always be available at: [www.chromeled.com](http://www.chromeled.com)

## REEL PACKAGING

Feeding Direction

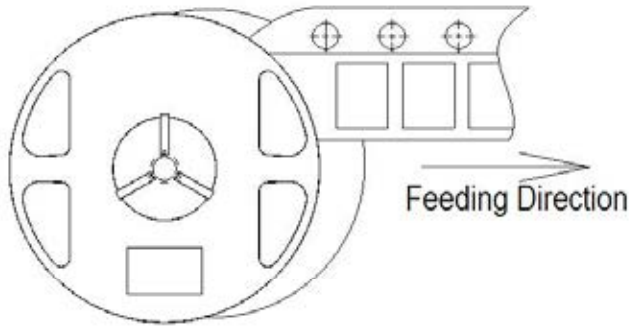

Dimensions of Reel (Unit: mm)

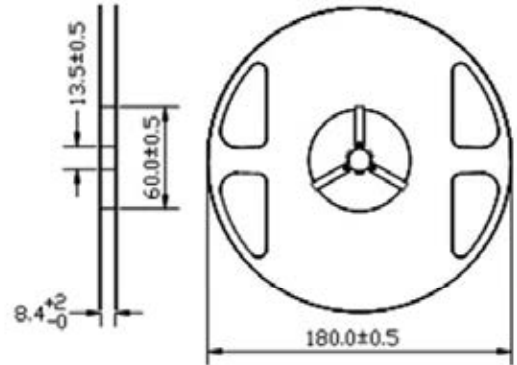

Dimensions of Tape (Unit: mm)

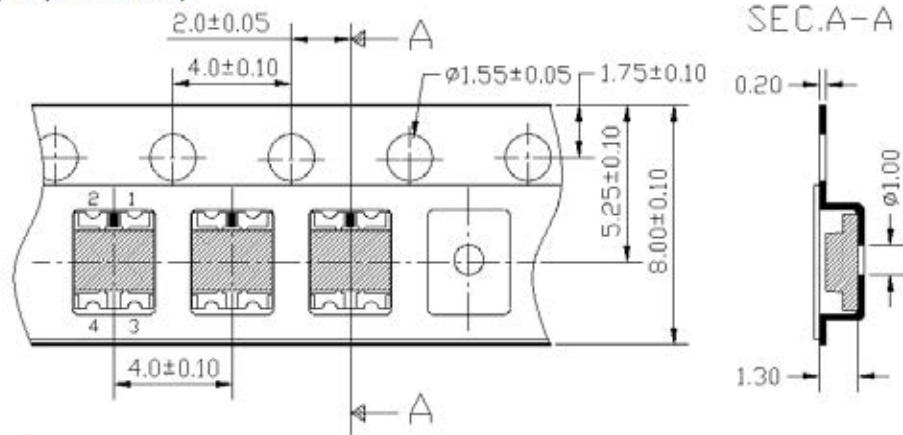

Arrangement of Tape

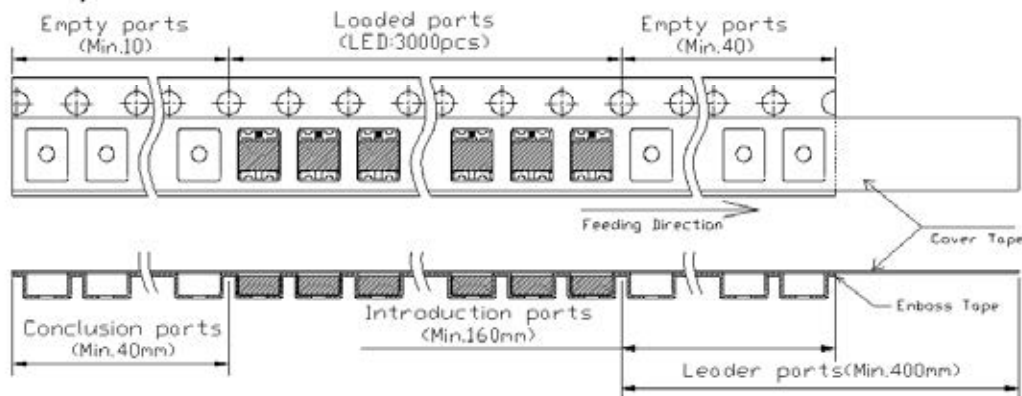

Notes:

1. Empty component pockets are sealed with top cover tape.
2. The maximum number of missing lamps is two.
3. The polarity mark is oriented towards the tape sprocket hole.
4. 3,000 pcs/Reel



ChromeLED Corp. reserves the right to make changes at any time in order to supply the best product possible. The most current version of this document will always be available at: [www.chromeled.com](http://www.chromeled.com)