

### Features

- ◆ 456W peak pulse power (8/20  $\mu$ s)
- ◆ Protects one data or power line
- ◆ Ultra low leakage: nA level
- ◆ Operating voltage: 3.3V
- ◆ Ultra low clamping voltage
- ◆ Complies with following standards:
  - IEC 61000-4-2 (ESD) immunity test
    - Air discharge:  $\pm 30$ kV
    - Contact discharge:  $\pm 30$ kV
  - IEC61000-4-4 (Lightning) 38A (8/20ns)
- ◆ RoHS Compliant
- ◆ Package: SOD-323

### Description

The ESDK3B3L0S3 is designed to replace multilayer varistors in portable applications such as cell phones, notebook computers and PDA's, using monolithic silicon technology to provide fast response time and ultra low ESD clamping voltage, making this device an ideal solution for protecting sensitive semiconductor components from damage. The ESDK3B3L0S3 complies with the IEC 61000-4-2 (ESD) standard with  $\pm 30$ kV air and  $\pm 30$ kV contact discharge. The ESDK3B3L0S3 is assembled into a lead-free SOD-323 package and will protect one unidirectional line. These devices will fit on the same PCB pad area as an 0805 MLV device.

### Circuit Diagram

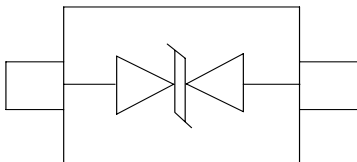

### Applications

- ◆ Cellular Handsets and Accessories
- ◆ Personal Digital Assistants
- ◆ Notebooks and Handhelds
- ◆ Portable Instrumentation
- ◆ Peripherals
- ◆ Pagers Peripherals
- ◆ Desktop and Servers

**Absolute Maximum Ratings :** ( $T_c=25^{\circ}\text{C}$  unless otherwise noted)

Parameter	Symbol	Value	Unit
Peak Pulse Power (8/20 $\mu\text{s}$ )	Ppk	456	W
Peak Pulse Current (8/20 $\mu\text{s}$ )	IPP	38	A
ESD per IEC 61000-4-2 (Air)	VESD	$\pm 30$	kV
ESD per IEC 61000-4-2 (Contact)		$\pm 30$	
Operating Temperature Range	TJ	-55 to +125	$^{\circ}\text{C}$
Storage Temperature Range	Tstg	-55 to +150	$^{\circ}\text{C}$

**Electrical Characteristics :** ( $T_c=25^{\circ}\text{C}$  unless otherwise noted)

Parameter	Symbol	Test Condition	Min	Typ	Max	Unit
Reverse Working Voltage	$V_{RWM}$				3.3	V
Breakdown Voltage	$V_{BR}$	$I_T = 1\text{mA}$	4.0	4.7	6.0	V
Reverse Leakage Current	$I_R$	$V_{RWM} = 3.3\text{V}$			0.1	$\mu\text{A}$
Clamping Voltage	$V_C$	$I_{PP} = 1\text{A}$ (8 / 20 $\mu\text{s}$ pulse)			7.0	V
Clamping Voltage	$V_C$	$I_{PP} = 38\text{A}$ (8 / 20 $\mu\text{s}$ pulse)			12.0	V
Junction Capacitance	$C_J$	$V_R = 0\text{V}$ , $f = 1\text{MHz}$		50	100	pF

**Portion Electronics Parameter**

Symbol	Parameter
$V_{RWM}$	Peak Reverse Working Voltage
$I_R$	Reverse Leakage Current @ $V_{RWM}$
$V_{BR}$	Breakdown Voltage @ $I_T$
$I_T$	Test Current
$I_{PP}$	Maximum Reverse Peak Pulse Current
$V_C$	Clamping Voltage @ $I_{PP}$

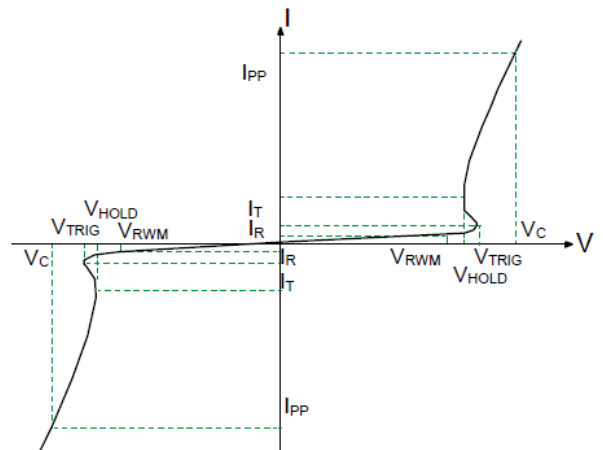

Typical Characteristics: ( $T_c=25^\circ\text{C}$  unless otherwise noted)

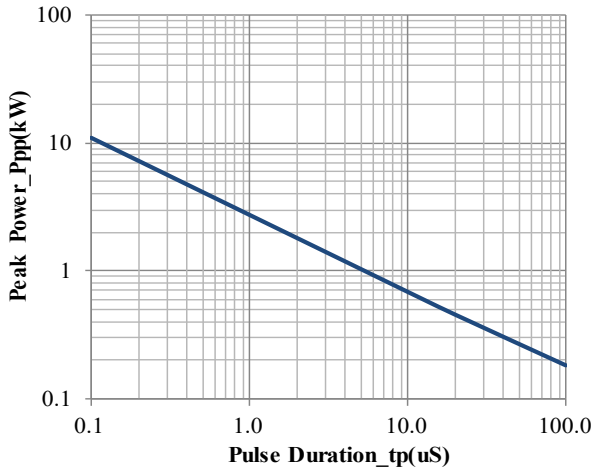

Peak Pulse Power vs. Pulse Time

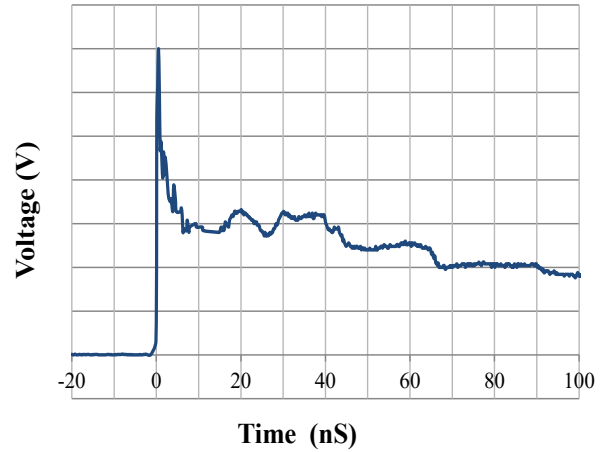

IEC61000-4-2 Pulse Waveform

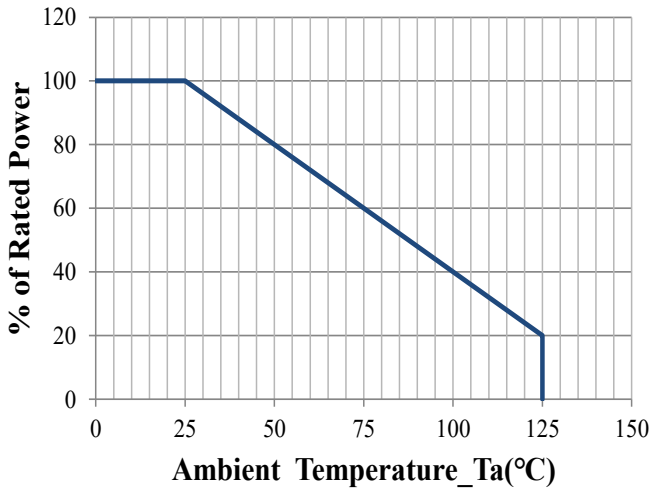

Power Derating Curve

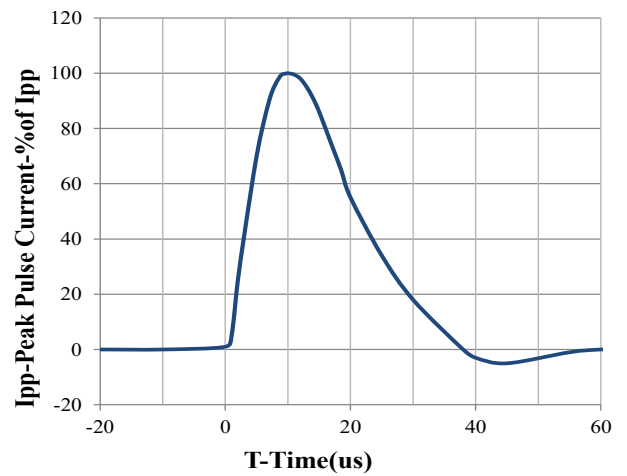

8 / 20us Pulse Waveform

### SOD-323 Package Outline Drawing

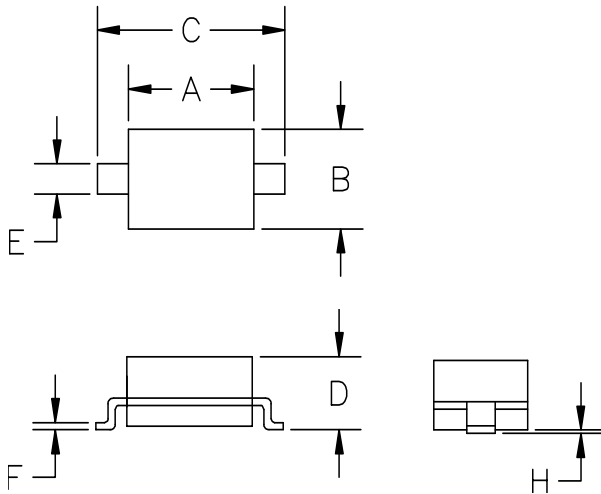

SYM	DIMENSIONS			
	MILLIMETERS		INCHES	
	MIN	MAX	MIN	MAX
A	1.50	1.80	0.060	0.071
B	1.20	1.40	0.045	0.054
C	2.30	2.70	0.090	0.107
D	-	1.10	-	0.043
E	0.30	0.40	0.012	0.016
F	0.10	0.25	0.004	0.010
H	-	0.10	-	0.004

### Suggested Land Pattern

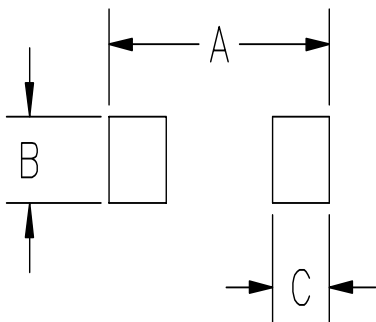

SYM	DIMENSIONS	
	MILLIMETERS	INCHES
A	3.15	0.120
B	0.80	0.031
C	0.80	0.031

## Soldering Parameters

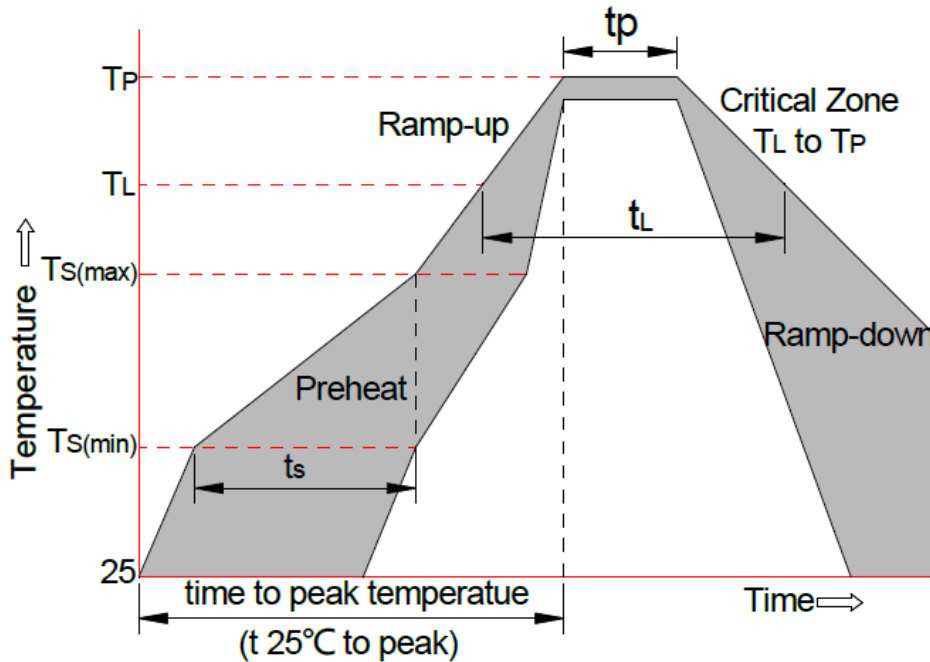

Reflow Condition		Pb-Free Assembly
Pre-heat	-Temperature Min ( $T_{S (min)}$ )	+150°C
	-Temperature Max ( $T_{S (max)}$ )	+200°C
	-Time (Min to Max) ( $t_s$ )	60-180 secs
Average ramp up rate( Liquid us Temp ( $T_L$ ) to peak)		3°C/sec. Max
$T_{S (max)}$ to $T_L$ -Ramp-up Rate		3°C/sec. Max
Reflow	-Temperature ( $T_L$ ) (Liquid us)	+217°C
	-Temperature ( $t_L$ )	60-150 secs
Peak Temp ( $T_p$ )		+260(+0/-5)°C
Time within 5°C of actual Peak Temp ( $t_p$ )		30 secs. Max
Ramp-down Rate		6 °C/secs. Max
xTime 25°C to Peak Temp ( $T_P$ )		8 min. Max
Do not exceed		+260°C