

SECTION X-X
INSULATION BARREL
SCALE 20:1

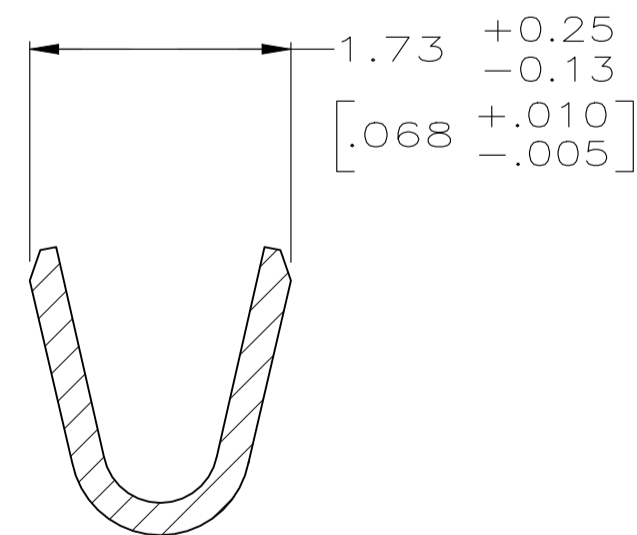

SECTION Y-Y
WIRE BARREL
SCALE 20:1

- 1 FOR MINI-APPLICATOR AND STRIPPER CRIMPER.
- 2 FOR HAND TOOL USE ONLY.
- 3 FOR STANDARD APPLICATOR PART #566171 ONLY.
- 4. WIRE RANGE OF 20-24 AWG. INSULATION RANGE OF 1.27/1.52 [.050-.060].
- 5. GOLD PLATING MAY NOT APPEAR ON CARRIER STRIP. NICKEL UNDERPLATE COVERS ENTIRE CONTACT.
- 6 GOLD PLATING PER MIL-G-45204.
NICKEL PLATING PER QQ-N-290.
TIN PLATING PER MIL-T-10727.
COPPER PLATING PER MIL-C-14550.
- 7 PLATED, 1.27[m [.000050] MIN GOLD ON LOCALIZED GOLD PLATE AREA AND ZONE 1 OVER 1.27[m [.000050] MIN NICKEL.
- 8 GOLD PLATED IN LOCALIZED GOLD PLATE AREA AS FOLLOWS:
0.76µm [.000030] MIN GOLD IN MATED AREA, GOLD FLASH ON REMAINDER OF LOCALIZED GOLD PLATE AREA AND ZONE 1 OF CONTACT, ALL OVER 1.27µm [.000050] MIN NICKEL UNDERPLATE.
OR
GOLD FLASH OVER PALLADIUM-NICKEL PLATE, 0.76µm [.000030] MIN TOTAL IN MATED AREA, GOLD FLASH ON REMAINDER OF LOCALIZED GOLD PLATE AREA AND ZONE 1 OF CONTACT, ALL OVER 1.27µm [.000050] MIN NICKEL UNDERPLATE.
- 9 PLATED WITH GOLD FLASH ON LOCALIZED GOLD PLATE AREA AND ZONE 1 OVER 0.76[m [.000030] MIN NICKEL.
- 10 PLATED WITH 2.54[m - 5.08[m [.000100 - .000200] TIN.
- 11 GOLD PLATED IN LOCALIZED GOLD PLATED AREA,
0.76[m [.000030] GOLD IN MATED AREA,
TIN PLATED WIRE BARRELS, OVER
1.27[m [.000050] NICKEL.
- 12 PLATED WITH GOLD FLASH IN LOCALIZED GOLD PLATE AREA,
TIN PLATED WIRE BARRELS, OVER
0.76[m [.000030] NICKEL.
- 13 GOLD PLATED IN LOCALIZED GOLD PLATE AREA,
0.38[m [.000015] GOLD IN MATED AREA,
GOLD FLASH ON REMAINDER, OVER 1.27[m [.000050] NICKEL.
- 14 AMP ITALY PART NUMBER ONLY.
- 15 GOLD PLATED IN LOCALIZED GOLD PLATE AREA,
1.27[m [.000050] GOLD IN MATED AREA,
GOLD FLASH ON REMAINDER, OVER
1.27[m [.000050] NICKEL.
- 16 GOLD PLATED IN LOCALIZED GOLD PLATE AREA,
0.03[m [.000001] GOLD IN MATED AREA,
0.76[m [.000030] MIN TIN PLATED WIRE BARRELS, ALL OVER
0.76[m [.000030] MIN NICKEL.
- 17 GOLD FLASH IN LOCALIZED GOLD PLATE AREA,
2.54[m [.000100] MIN TIN OR TIN-LEAD PLATED WIRE BARRELS, ALL OVER
0.76[m [.000030] MIN NICKEL.
- 18 COMPANY LOGO ON BOTTOM OF EITHER WIRE OR INSULATION BARRELS.

SUPERSEDED BY	STANDARD	5.84 [.230]	1,2	1	STRIP	6-66506-4	
	OBSOLETE	STANDARD	3.94 [.155]	1,1	3	STRIP	6-66506-3
	OBSOLETE	STANDARD	3.94 [.155]	1,6	1	STRIP	6-66506-2
		SMALL PACK	3.94 [.155]	8	1	LOOSE PIECE	6-66506-1
	OBSOLETE	STANDARD	3.94 [.155]	1,8	1	STRIP	6-66506-0
	OBSOLETE	STANDARD	3.94 [.155]	1,2	2	LOOSE PIECE	5-66506-9
	OBSOLETE	STANDARD	3.94 [.155]	1,1	2	LOOSE PIECE	5-66506-7
	OBSOLETE	STANDARD	3.94 [.155]	1,2	1	STRIP	2-66506-5
	OBSOLETE	STANDARD	3.94 [.155]	1,1	1	STRIP	2-66506-4
	OBSOLETE	STANDARD	-	10	1	STRIP	1-66506-4
	OBSOLETE	STANDARD	-	7	3	STRIP	1-66506-1
SUPERSEDED BY 1658539-4	STANDARD	-	9	2	LOOSE PIECE	1-66506-0	
	STANDARD	3.94 [.155]	8	2	LOOSE PIECE	66506-9	
	STANDARD	-	7	2	LOOSE PIECE	66506-8	
	STANDARD	-	9	1	STRIP	66506-4	
	STANDARD	3.94 [.155]	8	1	STRIP	66506-3	
	STANDARD	-	7	1	STRIP	66506-2	
	PACKAGING TYPE	B	FINISH	USE	TYPE	PART NUMBER	

THIS DRAWING IS A CONTROLLED DOCUMENT. DIMENSIONING AND TOLERANCING PER ASME Y14.5M-2009

APPROVED: S. WELDON, C. RICHARD, V. KUMAR

DATE: 9-9-86, 9-9-86, 9-10-86

NAME: PIN CONTACT, SIZE 20 DF, 20-24 AWG, AMPLIMITE

APPLICATION SPEC: 114-10000

SIZE: A1, CAGE CODE: 00779, DRAWING NO: 66506

WEIGHT: 0.000000

CUSTOMER DRAWING

SCALE: 10:1, SHEET: 1 of 1, REV: AT1

REVISIONS					
REV	DATE	DESCRIPTION	BY	CHK	APPV
AT1	21AUG2023	REVISED PER ECN-23-214059	AP	IT	