

## Descriptions

The ESD5305FB is a low capacitance TVS (Transient Voltage Suppressor) array designed to protect high speed data interfaces. It has been specifically designed to protect sensitive electronic components which are connected to data and transmission lines from over-stress caused by ESD (Electrostatic Discharge). The ESD5305FB incorporates four pairs of low capacitance steering diodes plus a TVS diode. The ESD5305FB may be used to provide ESD protection up to  $\pm 30\text{kV}$  (contact discharge) according to IEC61000-4-2, and withstand peak pulse current up to 6A (8/20 $\mu\text{s}$ ) according to IEC61000-4-5.

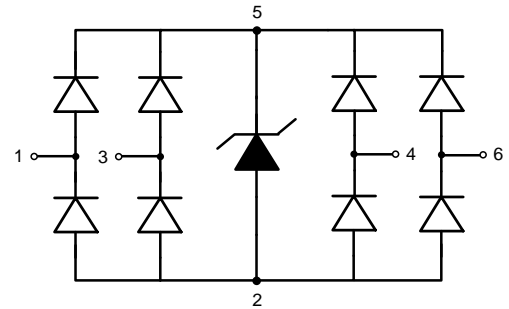

## Features

- Reverse stand-off voltage: 5V max.
- Transient protection for each line according to IEC61000-4-2 (ESD):  $\pm 30\text{kV}$  (contact discharge)  
IEC61000-4-5 (surge): 6A (8/20 $\mu\text{s}$ )
- Low capacitance:  $C_{I/O-GND} = 0.65\text{pF}$  typ. (VDD = floated)  
 $C_{I/O-GND} = 0.35\text{pF}$  typ. (VDD = 5V)
- Ultra-low leakage current:  $I_R < 1\text{nA}$  typ.
- Low clamping voltage:  $V_{CL} = 12.8\text{V}$  @  $I_{PP} = 16\text{A}$  (TLP)
- Solid-state silicon technology

## Applications

- USB 2.0
- HDMI 1.3
- SATA and eSATA
- DVI
- IEEE 1394
- PCI Express
- Portable Electronics
- Notebooks

**Absolute maximum ratings**

Parameter	Symbol	Rating	Unit
Peak pulse power ( $t_p = 8/20\mu s$ )	$P_{pk}$	84	W
Peak pulse current ( $t_p = 8/20\mu s$ )	$I_{PP}$	6	A
ESD according to IEC61000-4-2 air discharge	$V_{ESD}$	$\pm 30$	kV
ESD according to IEC61000-4-2 contact discharge		$\pm 30$	
Junction temperature	$T_J$	125	$^{\circ}C$
Operation temperature	$T_{OP}$	-40 to 85	$^{\circ}C$
Storage temperature	$T_{STG}$	-55 to 150	$^{\circ}C$
Lead temperature	$T_L$	260	$^{\circ}C$

**Electrical characteristics ( $T_A = 25^{\circ}C$ , unless otherwise noted)**

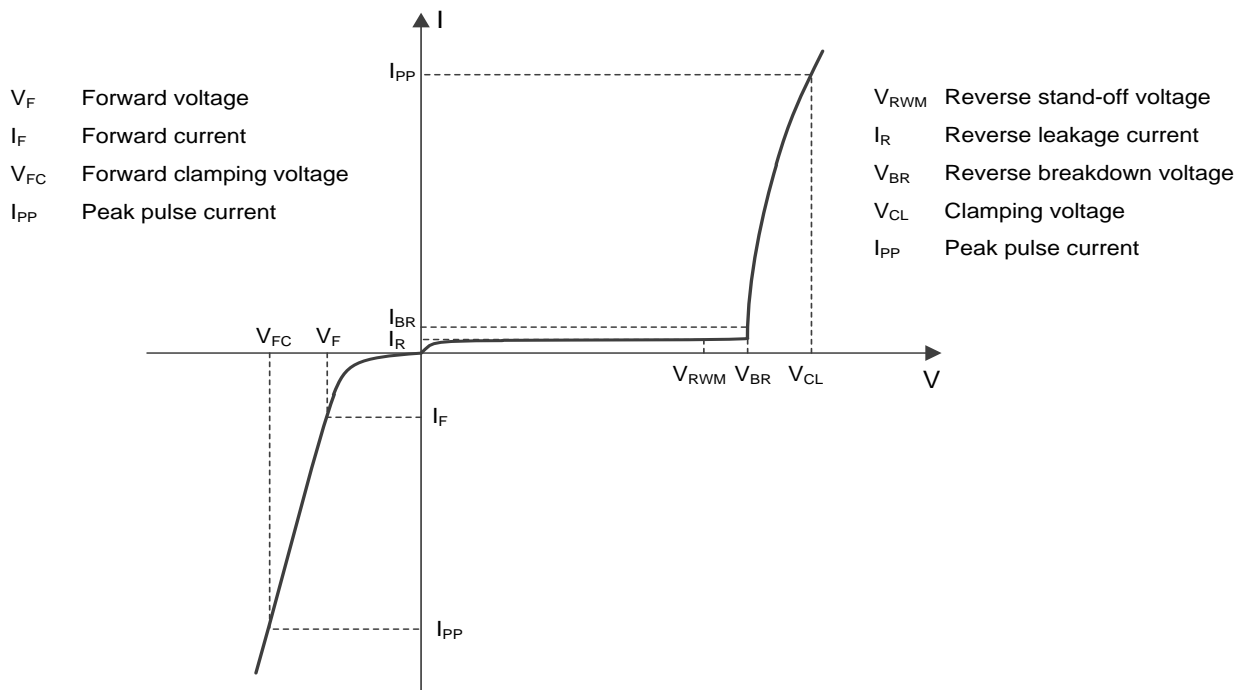

**Definitions of electrical characteristics**

**Electrical characteristics (T<sub>A</sub> = 25°C, unless otherwise noted)**

Parameter	Symbol	Condition	Min.	Typ.	Max.	Unit
Reverse stand-off voltage	V <sub>RWM</sub>				5.0	V
Reverse leakage current	I <sub>R</sub>	V <sub>RWM</sub> = 5V		<1	50	nA
Reverse breakdown voltage	V <sub>BR</sub>	I <sub>BR</sub> = 1mA	7.0	8.0	9.0	V
Forward voltage	V <sub>F</sub>	I <sub>F</sub> = 10mA	0.6	0.9	1.2	V
Clamping voltage <sup>1)</sup>	V <sub>CL</sub>	I <sub>PP</sub> = 16A, t <sub>p</sub> = 100ns		12.8		V
Dynamic resistance <sup>1)</sup>	R <sub>DYN</sub>			0.24		Ω
Clamping voltage <sup>2)</sup>	V <sub>CL</sub>	I <sub>PP</sub> = 1A, t <sub>p</sub> = 8/20μs			10	V
		I <sub>PP</sub> = 6A, t <sub>p</sub> = 8/20μs			14	V
Junction capacitance	C <sub>I/O - GND</sub>	V <sub>R</sub> = 0V, f = 1MHz, VDD = floated, any I/O to GND		0.65	1.0	pF
		V <sub>R</sub> = 0V, f = 1MHz, VDD = 5V, any I/O to GND		0.35	0.50	pF
	C <sub>I/O - I/O</sub>	V <sub>R</sub> = 0V, f = 1MHz, any I/O to I/O		0.35	0.50	pF

Notes:

- 1) TLP parameter: Z<sub>0</sub> = 50Ω, t<sub>p</sub> = 100ns, t<sub>r</sub> = 2ns, averaging window from 60ns to 80ns. R<sub>DYN</sub> is calculated from 10A to 30A.
- 2) Non-repetitive current pulse, according to IEC61000-4-5.

Typical characteristics ( $T_A = 25^\circ\text{C}$ , unless otherwise noted)

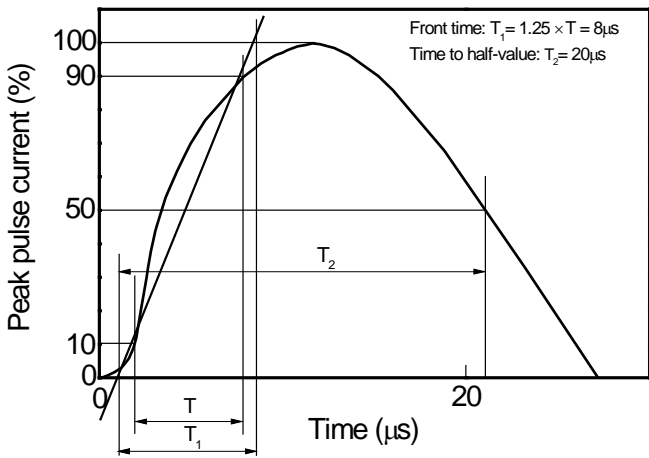

8/20µs waveform per IEC61000-4-5

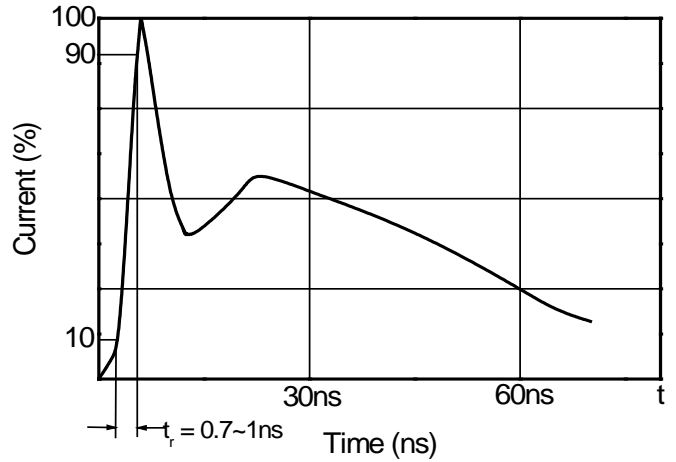

Contact discharge current waveform per IEC61000-4-2

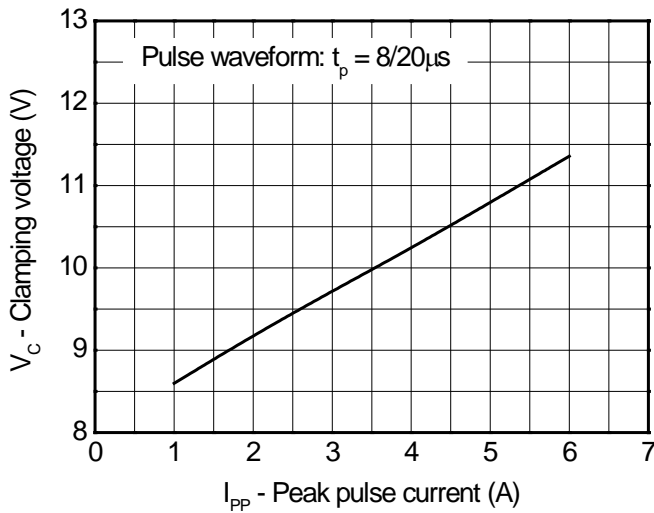

Clamping voltage vs. Peak pulse current

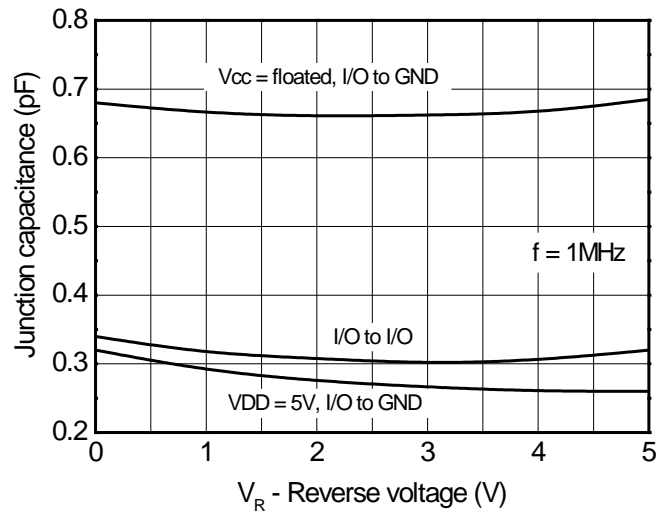

Capacitance vs. Reverse voltage

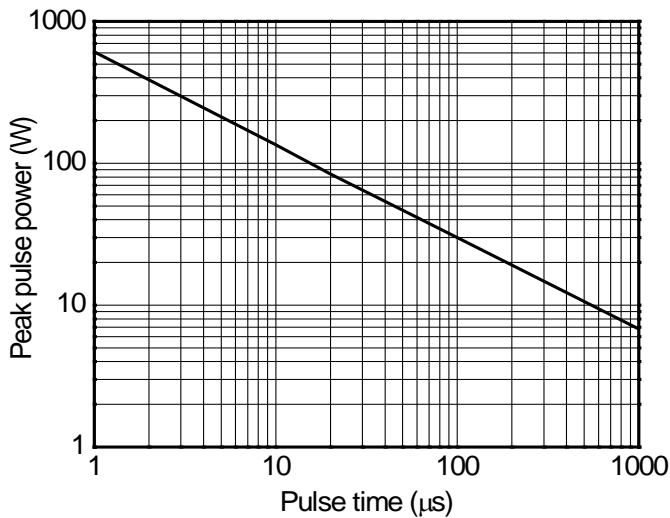

Non-repetitive peak pulse power vs. Pulse time

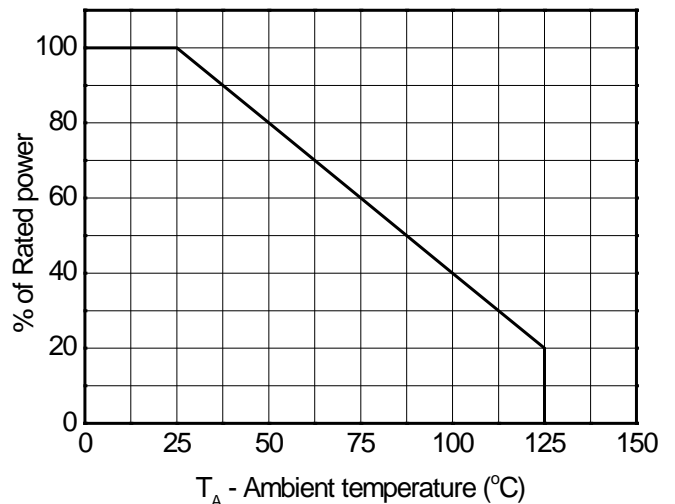

Power derating vs. Ambient temperature

Typical characteristics ( $T_A = 25^\circ\text{C}$ , unless otherwise noted)

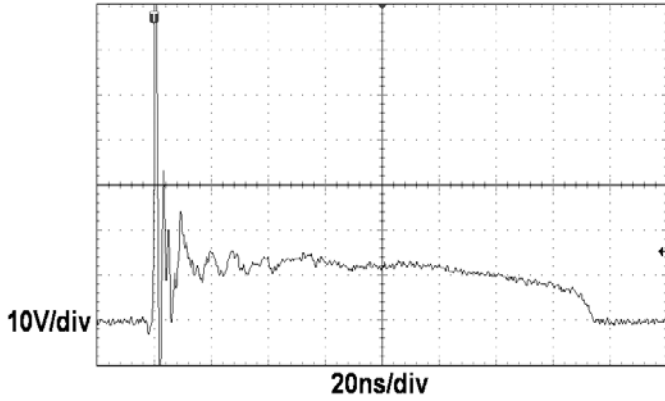

ESD clamping  
(+8kV contact discharge per IEC61000-4-2)

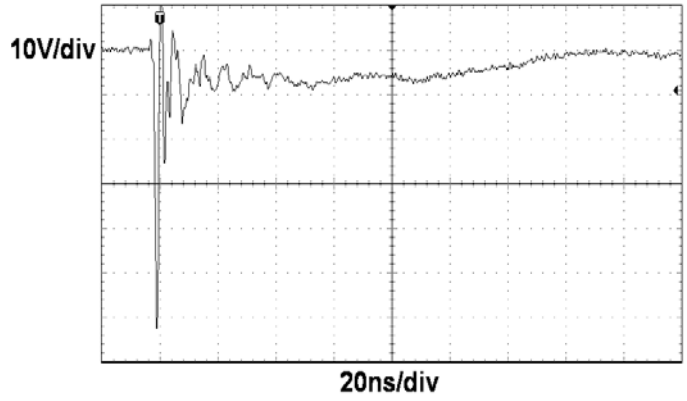

ESD clamping  
(-8kV contact discharge per IEC61000-4-2)

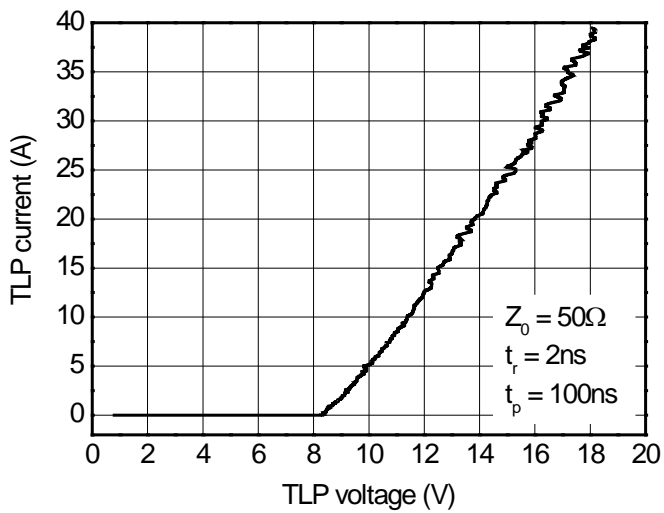

TLP Measurement

SOT23-6

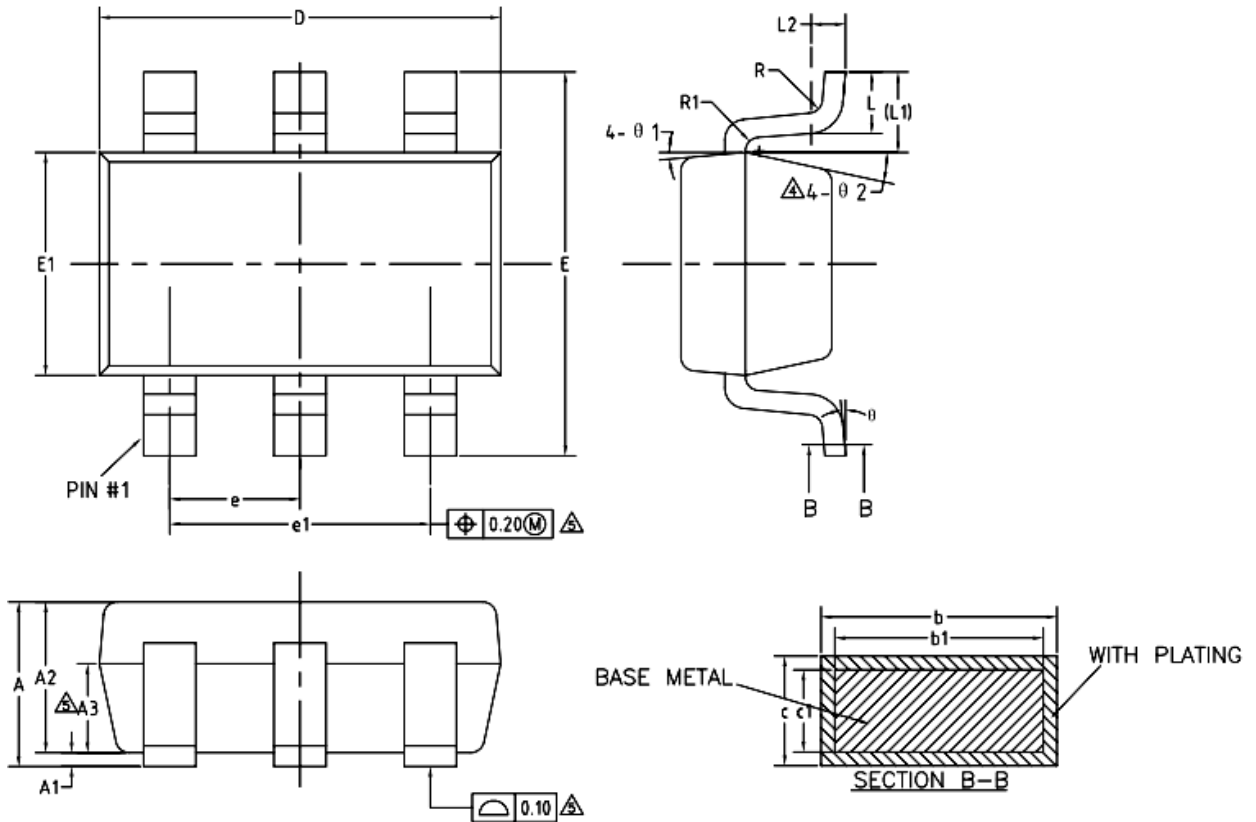

COMMON DIMENSIONS  
(UNITS OF MEASURE=MILLIMETER)

SYMBOL	MIN	NOM	MAX
A	—	—	1.25
A1	0	—	0.15
A2	1.00	1.10	1.20
A3	0.60	0.65	0.70
b	0.36	—	0.50
b1	0.36	0.38	0.45
c	0.14	—	0.20
c1	0.14	0.15	0.16
D	2.826	2.926	3.026
E	2.60	2.80	3.00
E1	1.526	1.626	1.726
$\Delta$ e	0.90	0.95	1.00
$\Delta$ e1	1.80	1.90	2.00
L	0.35	0.45	0.60
L1	0.59REF		
L2	0.25BSC		
$\Delta$ R	0.10	—	—
$\Delta$ R1	0.10	—	0.20
$\theta$	0°	—	8°
$\theta_1$	3°	5°	7°
$\Delta$ $\theta_2$	6°	—	14°

**Marking**

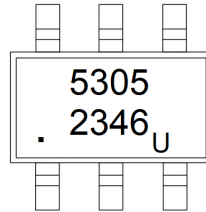

**Ordering information**

Order code	Package	Base qty	Delivery mode
UMW ESD5305FB	SOT23-6	3000	Tape and reel