

## Features

Wide voltage operation  
 - VCC = 1.8V to 5.5V  
 Low-Power Devices (ISB = 3  $\mu$ A @ 5.5V) Available  
 Operating Ambient Temperature: -40°C to +85°C  
 Internally Organized 16,384 X 8 (128K), 32,768 X 8 (256K)  
 Two-wire Serial Interface  
 Schmitt Trigger, Filtered Inputs for Noise Suppression  
 Bidirectional Data Transfer Protocol  
 1 MHz(5V), 400 kHz ( 1.8V, 2.7V, 3.3V) Compatibility  
 Write Protect Pin for Hardware Data Protection  
 64-byte Page (128K/256K) Write Modes  
 Partial Page Writes Allowed  
 Self-timed Write Cycle (5 ms max)  
 High-reliability  
 - Endurance: 1 Million Write Cycles  
 - Data Retention: 100 Years  
 8-lead DIP, 8-lead JEDEC SOP and 8-lead MSOP Packages

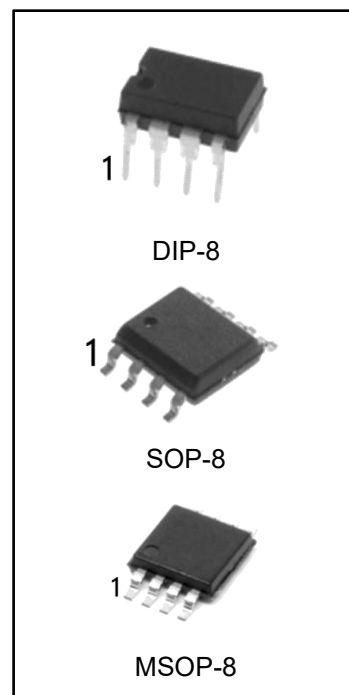

## Ordering Information

DEVICE	Package Type	MARKING	Packing	Packing Qty
AT24C128N	DIP-8	24C128	TUBE	2000pcs/box
AT24C256N	DIP-8	24C256	TUBE	2000pcs/box
AT24C128M/TR	SOP-8	24C128	REEL	2500pcs/reel
AT24C256M/TR	SOP-8	24C256	REEL	2500pcs/reel
AT24C128MM/TR	MSOP-8	C128	REEL	3000pcs/reel
AT24C256MM/TR	MSOP-8	C256	REEL	3000pcs/reel

## General Description

The AT24C128 / AT24C256 provides 131,072/262,144 bits of serial electrically erasable and programmable read-only memory (EEPROM) organized as 4096 words of 8 bits each. The device is optimized for use in many industrial and commercial applications where low-power and low-voltage operation are required. It is available in 8-lead MSOP packages and is accessed via a Two-wire serial interface.

## Pin Configuration

DIP-8/SOP-8/MSOP-8

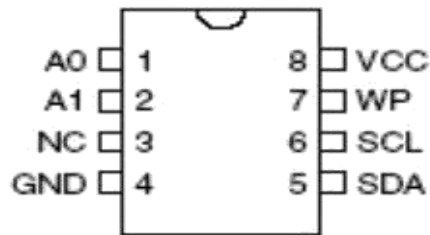

## Pin Descriptions

Pin Number	Designation	Type	Name and Functions
1 – 2	A0 – A1	I	<p>Address Inputs</p> <p><b>DEVICE/PAGE ADDRESSES (A1, A0):</b> The A1 and A0 pins are device address inputs that are hardwired or left not connected for hardware compatibility with other 24Cxx devices. When the pins are hardwired, as many as four 128K/256K devices may be addressed on a single bus system (device addressing is discussed in detail under the Device Addressing section). If the pins are left floating, the A2, A1 and A0 pins will be internally pulled down to GND if the capacitive coupling to the circuit board VCC plane is &lt;3 pF. If coupling is &gt;3 pF, recommends connecting the address pins to GND.</p>
5	SDA	I/O& Open-drain	<p>Serial Data</p> <p><b>SERIAL DATA (SDA):</b>The SDA pin is bi-directional for serial data transfer. This pin is open-drain driven and may be wire-ORed with any number of other open-drain or open-collector devices.</p>
6	SCL	I	<p>Serial Clock Input</p> <p><b>SERIAL CLOCK (SCL):</b> The SCL input is used to positive edge clock data into eachEEPROM device and negative edge clock data out of each device.</p>
7	WP	I	<p>Write Protect</p> <p><b>WRITE PROTECT (WP):</b>The write protect input, when connected to GND, allows normal write operations. When WP is connected high to VCC, all write operations to the memory are inhibited. If the pin is left floating, the WP pin will be internally pulled down to GND if the capacitive coupling to the circuit board VCC plane is &lt;3 pF. If coupling is &gt;3 pF, recommends connecting the pin to GND. Switching WP to VCC prior to a write operation creates a software write protect function. The write protection feature is enabled and operates as shown in the following Table 1.</p>
4	GND	P	Ground
8	VCC	P	Power Supply
3	NC	NC	No connect

**Table 1: Write Protect**

WP Pin Status:	Part of the Array Protected	
	AT24C128	AT24C256
At VCC	Full (128K) Array	Full (256K) Array
At GND	Normal Read/Write Operations	

## Block Diagram

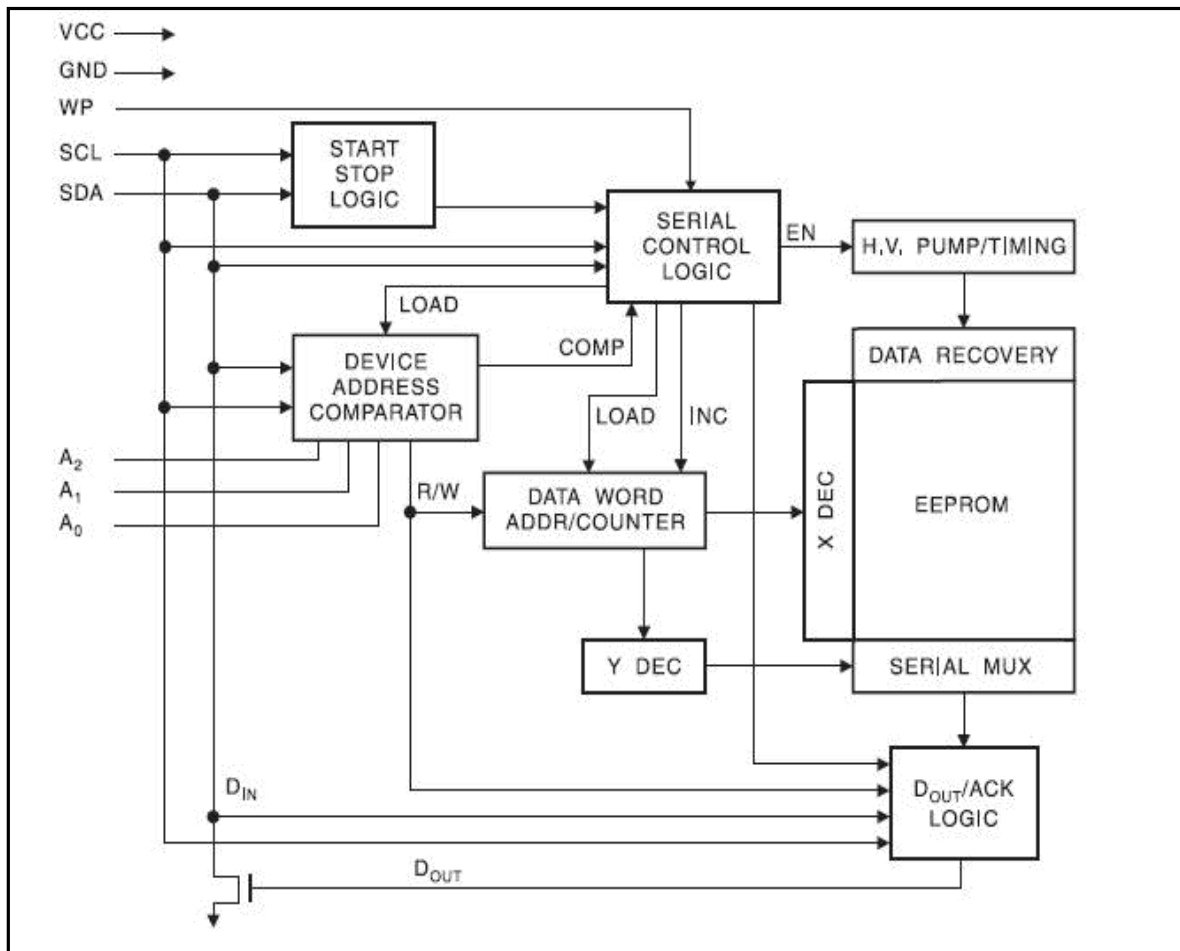

## Functional Description

### 1. Memory Organization

AT24C128 , 128K SERIAL EEPROM: The 128K is internally organized as 256 pages of 64 bytes each. Random word addressing requires a 14-bit data word address.

AT24C256 , 256K SERIAL EEPROM: The 256K is internally organized as 512 pages of 64 bytes each. Random word addressing requires a 15-bit data word address.

### 2. Device Operation

CLOCK and DATA TRANSITIONS: The SDA pin is normally pulled high with an external device.

Data on the SDA pin may change only during SCL low time periods (see to Figure 1 on page 5). Data changes during SCL high periods will indicate a start or stop condition as defined below.

**START CONDITION:** A high-to-low transition of SDA with SCL high is a start condition which must precede any other command (see to Figure 2 on page 5).

**STOP CONDITION:** A low-to-high transition of SDA with SCL high is a stop condition. After a read sequence, the stop command will place the EEPROM in a standby power mode (see Figure 2 on page 5).

**ACKNOWLEDGE:** All addresses and data words are serially transmitted to and from the EEPROM in 8-bit words. The EEPROM sends a “0” to acknowledge that it has received each word. This happens during the ninth clock cycle.

**STANDBY MODE:** The AT24C128 / AT24C256 features a low-power standby mode which is enabled: (a) upon power-up and (b) after the receipt of the STOP bit and the completion of any internal operations

**MEMORY RESET:** After an interruption in protocol, power loss or system reset, any two-wire part can be reset by following these steps:

- 1.Clock up to 9 cycles.
- 2.Look for SDA high in each cycle while SCL is high.
- 3.Create a start condition

**Figure1.Data Validity**

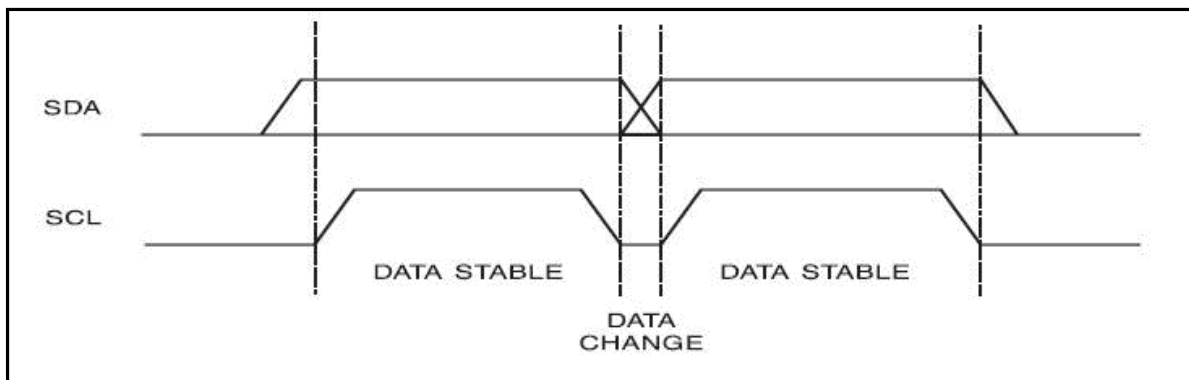

**Figure2.Start and Stop Definition**

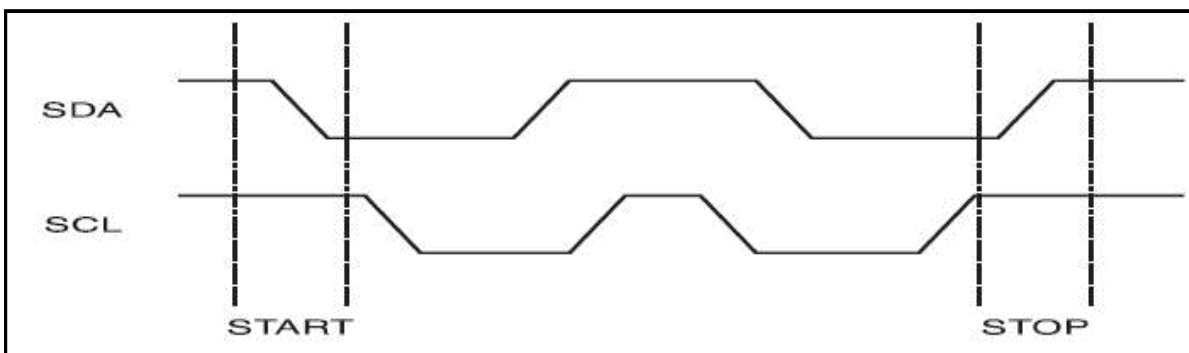
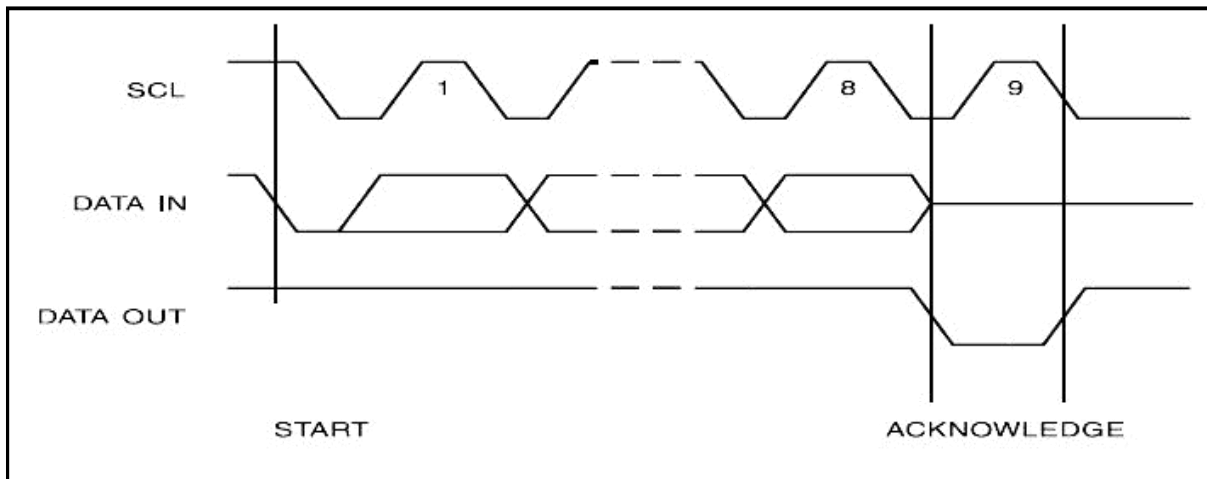

Figure3.Output Acknowledge



### 3. Device Addressing

The 128K/256K EEPROM devices all require an 8-bit device address word following a start condition to enable the chip for a read or write operation (see to Figure 4 on page 5).

The device address word consists of a mandatory “1”, “0” sequence for the first four most significant bits as shown. This is common to all the Serial EEPROM devices.

The 128K/256K uses the three device address bits A2, A1, A0 to allow as many as eight devices on the same bus. These bits must compare to their corresponding hardwired input pins. The A2, A1, and A0 pins use an internal proprietary circuit that biases them to a logic low condition if the pins are allowed to float.

The eighth bit of the device address is the read/write operation select bit. A read operation is initiated if this bit is high and a write operation is initiated if this bit is low.

Upon a compare of the device address, the EEPROM will output a “0”. If a compare is not made, the chip will return to a standby state.

**NOISE PROTECTION:** Special internal circuitry placed on the SDA and SCL pins prevent small noise spikes from activating the device.

**DATA SECURITY:** The AT24C128 / AT24C256 has a hardware data protection scheme that allows the user to write protect the entire memory when the WP pin is at VCC.

### 4. Write Operations

**BYTE WRITE:** A write operation requires an 8-bit data word address following the device address word and acknowledgment. Upon receipt of this address, the EEPROM will again respond with a “0” and then clock in the first 8-bit data word. Following receipt of the 8-bit data word, the EEPROM will output a “0” and the addressing device, such as a microcontroller, must terminate the write sequence with a stop condition. At this time the EEPROM enters an internally timed write cycle,  $t_{WR}$ , to the nonvolatile memory. All inputs are disabled during this write cycle and the EEPROM will not respond until the write is complete (see Figure 5 on page 8).

**PAGE WRITE:** The 128K/256K devices are capable of 64-byte page writes.

A page write is initiated the same as a byte write, but the microcontroller does not send a stop condition after the first data word is clocked in. Instead, after the EEPROM acknowledges receipt of the first data word, the microcontroller can transmit up to 63 more data words. The EEPROM will respond with a “0” after each data word received. The microcontroller must terminate the page write sequence with a stop condition (see Figure 6 on page 8).

The data word address lower six (128K/256K) bits are internally incremented following the receipt of each data word. The higher data word address bits are not incremented, retaining the memory page row location. When the word address, internally generated, reaches the page boundary, the following byte is placed at the beginning of the same page. If more than 64 data words are transmitted to the EEPROM, the data word address will “roll over” and previous data will be overwritten.

**ACKNOWLEDGE POLLING:** Once the internally timed write cycle has started and the EEPROM inputs are disabled, acknowledge polling can be initiated. This involves sending a start condition followed by the device address word. The read/write bit is representative of the operation desired. Only if the internal write cycle has completed will the EEPROM respond with a “0”, allowing the read or write sequence to continue.

## 5. Read Operations

Read operations are initiated the same way as write operations with the exception that the read/write select bit in the device address word is set to “1”. There are three read operations: current address read, random address read and sequential read.

**CURRENT ADDRESS READ:** The internal data word address counter maintains the last address accessed during the last read or write operation, incremented by one. This address stays valid between operations as long as the chip power is maintained. The address “roll over” during read is from the last byte of the last memory page to the first byte of the first page. The address “roll over” during write is from the last byte of the current page to the first byte of the same page.

Once the device address with the read/write select bit set to “1” is clocked in and acknowledged by the EEPROM, the current address data word is serially clocked out. The microcontroller does not respond with an input “0” but does generate a following stop condition (see Figure 7 on page 8).

**RANDOM READ:** A random read requires a “dummy” byte write sequence to load in the data word address. Once the device address word and data word address are clocked in and acknowledged by the EEPROM, the microcontroller must generate another start condition. The microcontroller now initiates a current address read by sending a device address with the read/write select bit high. The EEPROM acknowledges the device address and serially clocks out the data word. The microcontroller does not respond with a “0” but does generate a following stop condition (see Figure 8 on page 8).

**SEQUENTIAL READ:** Sequential reads are initiated by either a current address read or a random address read. After the microcontroller receives a data word, it responds with an acknowledge. As long as the EEPROM receives an acknowledge, it will continue to increment the data word address and serially clock out sequential data words. When the memory address limit is reached, the data word address will “roll over” and the sequential read will continue. The sequential read operation is terminated when the microcontroller does not respond with a “0” but does generate a following stop condition(see Figure 9 on page 9)

**Figure 4. Device Address**

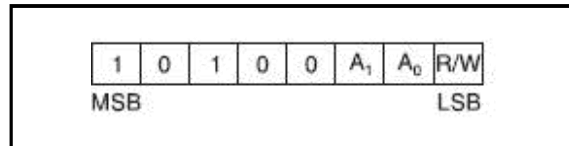

**Figure 5. Byte Write**

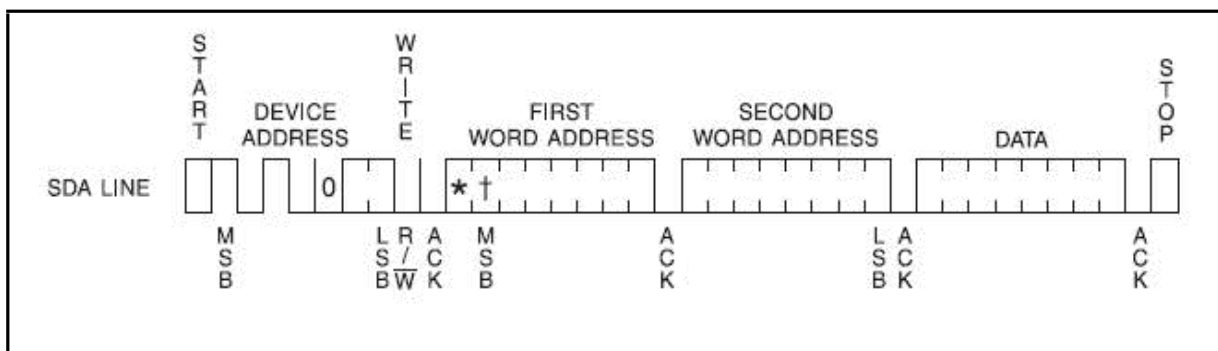

**Figure 6. Page Write**

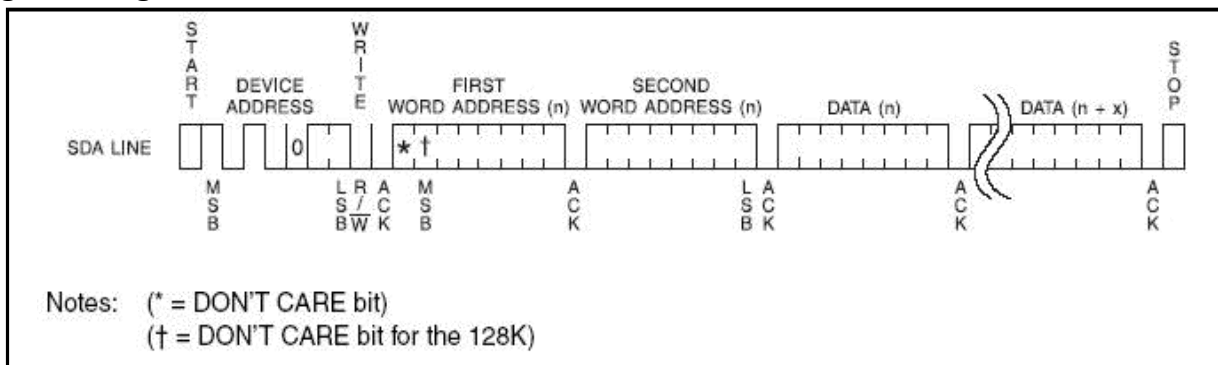

**Figure 7. Current Address Read**

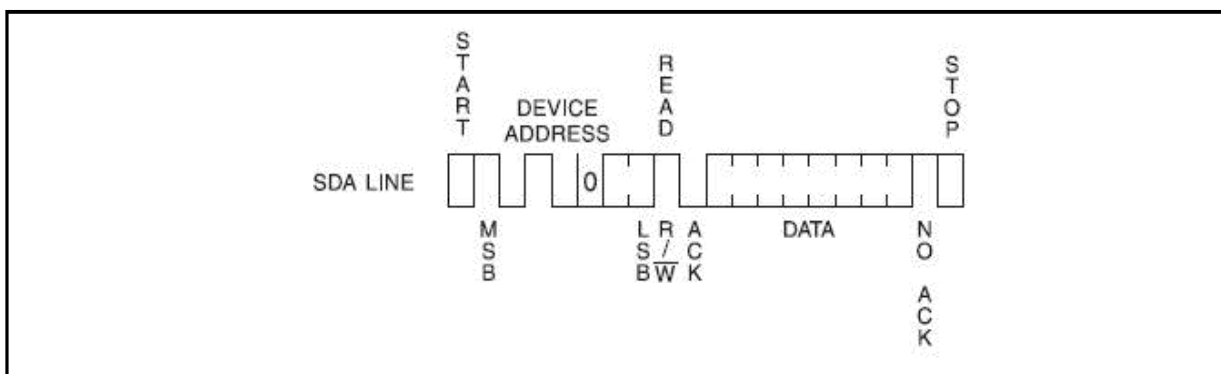



Figure 8. Random Read

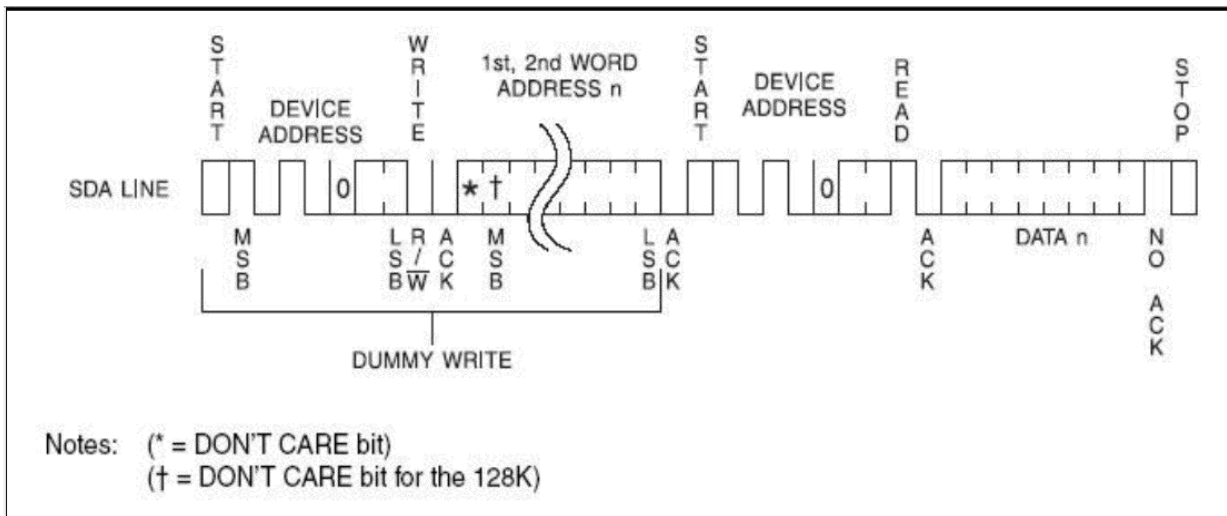
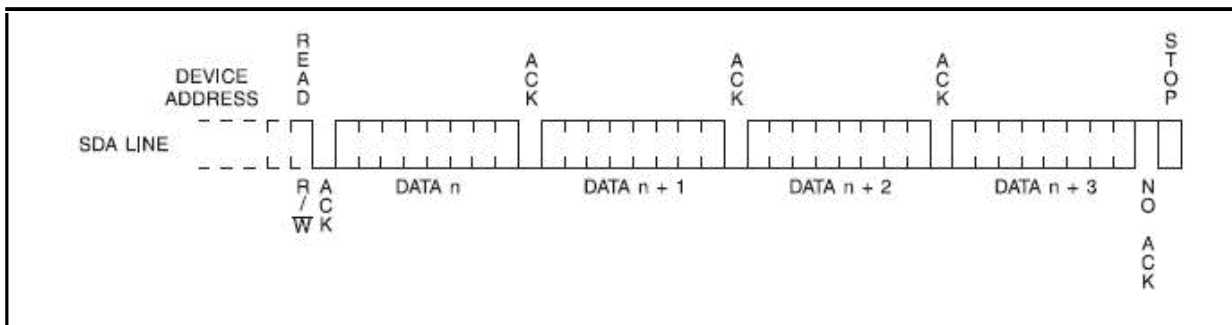

Figure 9. Sequential Read



## Electrical Characteristics

### Absolute Maximum Stress Ratings

Condition	Min	Max
DC Supply Voltage	-0.3V	+6.5V
Input / Output Voltage	GND-0.3V	VCC+0.3V
Operating Ambient Temperature	-40°C	+85°C Storage
Temperature	-55°C	+125°C
Lead Temperature (Soldering, 10 seconds)	-	245°C

## Comments

Stresses above those listed under "Absolute Maximum Ratings" may cause permanent damage to this device. These are stress ratings only. Functional operation of this device at these or any other conditions above those indicated in the operational sections of this specification is not implied or intended. Exposure to the absolute maximum rating conditions for extended periods may affect device reliability.



## DC Electrical Characteristics

Applicable over recommended operating range from: TA = -40°C to +85°C, VCC = +1.8V to +5.5V (unless otherwise noted)

Parameter	Symbol	Min.	Typ.	Max.	Unit	Condition
Supply Voltage	V <sub>CC1</sub>	1.8	-	5.5	V	
Supply Voltage	V <sub>CC2</sub>	2.5	-	5.5	V	
Supply Voltage	V <sub>CC3</sub>	2.7	-	5.5	V	
Supply Voltage	V <sub>CC4</sub>	4.5	-	5.5	V	
Supply Current VCC = 5.0V	I <sub>CC1</sub>	-	0.4	1.0	mA	READ at 400 kHz
Supply Current VCC = 5.0V	I <sub>CC2</sub>	-	2.0	3.0	mA	WRITE at 400 kHz
Standby Current VCC = 1.8V	I <sub>SB1</sub>	- 0.6		1.0	μA	V <sub>IN</sub> = VCC or VSS
Standby Current VCC = 2.5V	I <sub>SB2</sub>	- 1.0		2.0	μA	V <sub>IN</sub> = VCC or VSS
Standby Current VCC = 2.7V	I <sub>SB3</sub>	- 1.0		2.0	μA	V <sub>IN</sub> = VCC or VSS
Standby Current VCC = 5.0V	I <sub>SB4</sub>	- 1.0		3.0	μA	V <sub>IN</sub> = VCC or VSS
Input Leakage Current	I <sub>LI</sub>	-	0.10	3.0	μA	V <sub>IN</sub> = VCC or VSS
Output Leakage Current	I <sub>LO</sub>	-	0.05	3.0	μA	V <sub>OUT</sub> = VCC or VSS
Input Low Level	V <sub>IL</sub>	-0.6	--	VCCx0.3	V	
Input High Level	V <sub>IH</sub>	VCCx0.7	-	VCC+0.5	V	
Output Low Level VCC =5.0V	V <sub>OL3</sub>	-	-	0.4 V		I <sub>OL</sub> = 3.0 mA
Output Low Level VCC =3.0V	V <sub>OL2</sub>	-	-	0.4	V	I <sub>OL</sub> = 2.1 mA
Output Low Level VCC =1.8V	V <sub>OL1</sub>	-	-	0.2	V	I <sub>OL</sub> = 0.15 mA

## Pin Capacitance

Applicable over recommended operating range from TA=25°C, f=1.0MHz,VCC=+1.8V

Parameter	Symbol	Min.	Typ.	Max.	Unit	Condition
Input/Output Capacitance (SDA)	C <sub>I/O</sub>	-	-	8	pF	V <sub>I/O</sub> = 0V
Input Capacitance (A0, A1, A2, SCL)	C <sub>IN</sub>	-	-	6	pF	V <sub>IN</sub> = 0V

## AC Electrical Characteristics

Applicable over recommended operating range from TA=-40°C to+85°C,VCC=+1.8V to+5.5V,CL=1TTL Gate and 100PF(unless otherwise noted)

Parameter Symbol		1.8, 2.7, 5.0-volt			Units
		Min.	Typ.	Max.	
Clock Frequency, SCL	f <sub>SCL</sub>	-	-	400	kHz
Clock Pulse Width Low	t <sub>LOW</sub>	1.2	-	-	μs

Clock Pulse Width High	$t_{HIGH}$	0.6	-	-	$\mu s$
Noise Suppression Time	$t_i$	-	-	50	ns
Clock Low to Data Out Valid	$t_{AA}$	0.1	-	0.9	$\mu s$
Time the bus must be free before a new transmission can start	$t_{BUF}$	1.2	-	-	$\mu s$
Start Hold Time	$t_{HD.STA}$	0.6	-	-	$\mu s$
Start Setup Time	$t_{SU.STA}$	0.6	-	-	$\mu s$
Data In Hold Time	$t_{HD.DAT}$	0	-	-	$\mu s$
Data In Setup Time	$t_{SU.DAT}$	100	-	-	ns
Inputs Rise Time	$t_r$	-	-	0.3	$\mu s$
Inputs Fall Time	$t_f$	-	-	300	ns
Stop Setup Time	$t_{SU.STO}$	0.6	-	-	$\mu s$
Data Out Hold Time	$t_{DH}$		50 -	-	ns
Write Cycle Time	$t_{WR}$	-	-	5	ms
5.0V, 25 °C, Byte Mode	Endurance	1M	-	-	Write Cycles

### Bus Timing

Figure 10. SCL: serial Clock, SDA: Serial Data I/O

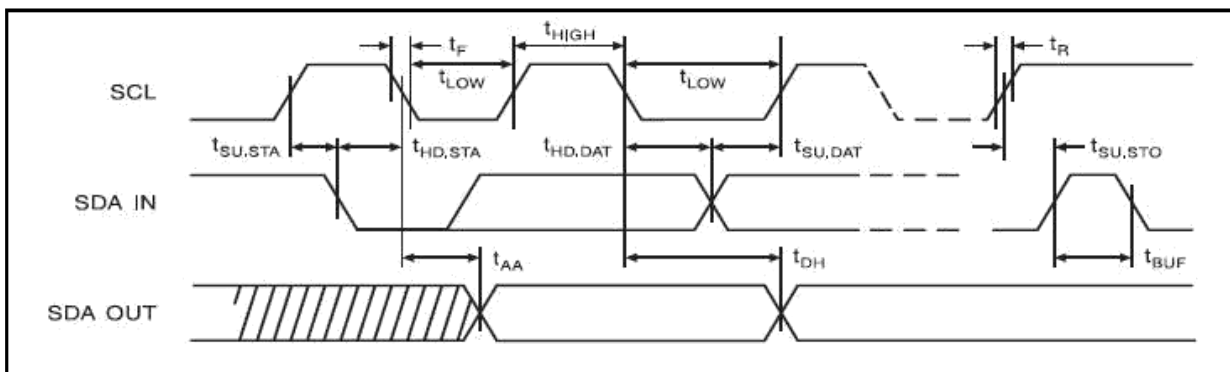

### Write Cycle Timing

Figure 11. SCL: Serial Clock, SDA: Serial Data I/O

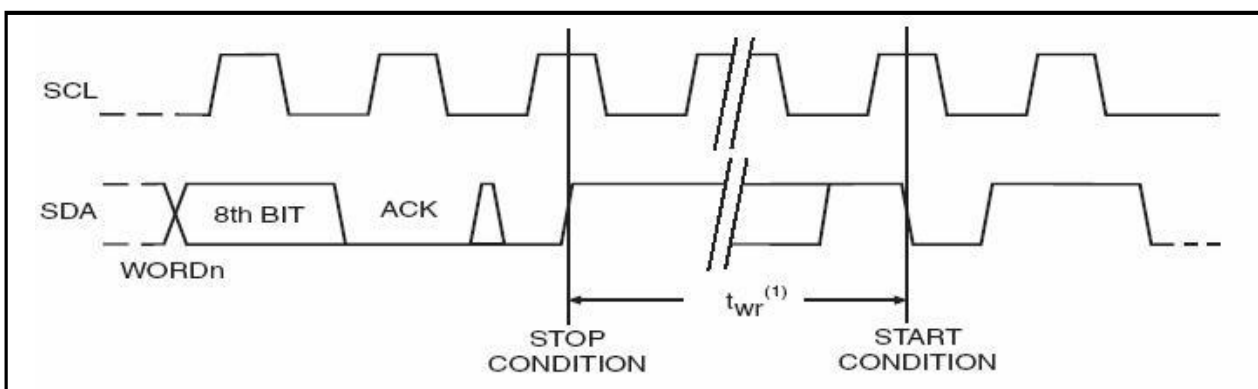

**Note:** 1. The write cycle time  $t_{WR}$  is the time from a valid stop condition of a write sequence to the end of the internal clear/write cycle.

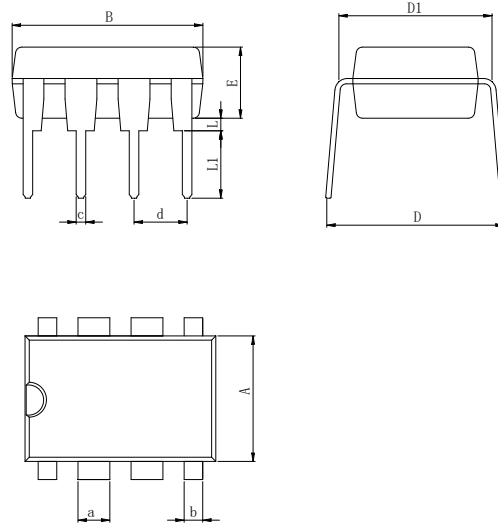
**PHYSICAL DIMENSIONS**
**DIP-8**

**Dimensions In Millimeters(DIP-8)**

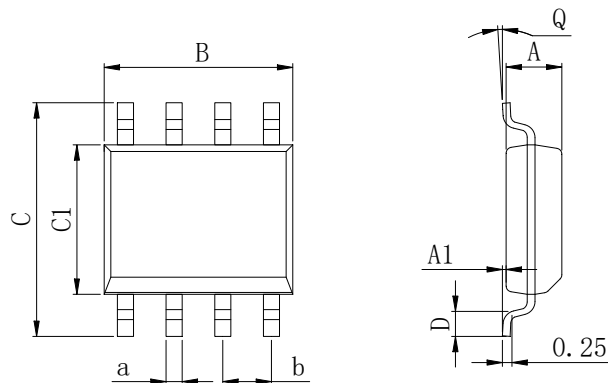
Symbol:	A	B	D	D1	E	L	L1	a	b	c	d
<b>Min:</b>	6.10	9.00	8.10	7.42	3.10	0.50	3.00	1.50	0.85	0.40	2.54 BSC
<b>Max:</b>	6.68	9.50	10.9	7.82	3.55	0.70	3.60	1.55	0.90	0.50	

**SOP-8**

**Dimensions In Millimeters(SOP-8)**

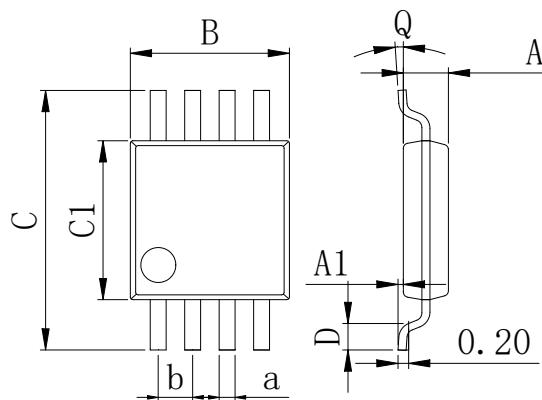
Symbol:	A	A1	B	C	C1	D	Q	a	b
<b>Min:</b>	1.35	0.05	4.90	5.80	3.80	0.40	0°	0.35	1.27 BSC
<b>Max:</b>	1.55	0.20	5.10	6.20	4.00	0.80	8°	0.45	

MSOP-8



Dimensions In Millimeters(MSOP-8)									
Symbol:	A	A1	B	C	C1	D	Q	a	b
Min:	0.80	0.05	2.90	4.75	2.90	0.35	0°	0.25	0.65 BSC
Max:	0.90	0.20	3.10	5.05	3.10	0.75	8°	0.35	

## Revision History

DATE	REVISION	PAGE
2019-10-8	New	1-14
2023-8-31	Update encapsulation type、 Update Lead Temperature、 Updated DIP-8 dimension	1、 8、 11

**IMPORTANT STATEMENT:**

Huaguan Semiconductor reserves the right to change its products and services without notice. Before ordering, the customer shall obtain the latest relevant information and verify whether the information is up to date and complete. Huaguan Semiconductor does not assume any responsibility or obligation for the altered documents.

Customers are responsible for complying with safety standards and taking safety measures when using Huaguan Semiconductor products for system design and machine manufacturing. You will bear all the following responsibilities: Select the appropriate Huaguan Semiconductor products for your application; Design, validate and test your application; Ensure that your application meets the appropriate standards and any other safety, security or other requirements. To avoid the occurrence of potential risks that may lead to personal injury or property loss.

Huaguan Semiconductor products have not been approved for applications in life support, military, aerospace and other fields, and Huaguan Semiconductor will not bear the consequences caused by the application of products in these fields. All problems, responsibilities and losses arising from the user's use beyond the applicable area of the product shall be borne by the user and have nothing to do with Huaguan Semiconductor, and the user shall not claim any compensation liability against Huaguan Semiconductor by the terms of this Agreement.

The technical and reliability data (including data sheets), design resources (including reference designs), application or other design suggestions, network tools, safety information and other resources provided for the performance of semiconductor products produced by Huaguan Semiconductor are not guaranteed to be free from defects and no warranty, express or implied, is made. The use of testing and other quality control technologies is limited to the quality assurance scope of Huaguan Semiconductor. Not all parameters of each device need to be tested.

The documentation of Huaguan Semiconductor authorizes you to use these resources only for developing the application of the product described in this document. You have no right to use any other Huaguan Semiconductor intellectual property rights or any third party intellectual property rights. It is strictly forbidden to make other copies or displays of these resources. You should fully compensate Huaguan Semiconductor and its agents for any claims, damages, costs, losses and debts caused by the use of these resources. Huaguan Semiconductor accepts no liability for any loss or damage caused by infringement.