

AAA F L P

SERIES: **Q-G° CONNECTOR**

OF CONTACT PINS: **3 - 3 PIN**
4 - 4 PIN

GENDER: **FEMALE**

FINISH: **BLANK** - NICKEL CONNECTOR, & GREEN INSERT
B - BLACK CONNECTOR, & BLACK INSERT

CONTACT PIN PLATING: **BLANK** - SILVER
AU - GOLD

HANDLE: **BLANK** - IF HANDLE & STRAIN RELIEF ARE BOTH BLACK
B - BLACK, IF HANDLE & STRAIN RELIEF ARE DIFFERENT COLORS
W - WHITE
G - GREEN
Y - YELLOW

STRAIN RELIEF: **BLANK** - IF HANDLE & STRAIN RELIEF ARE BOTH BLACK
B - BLACK, IF HANDLE & STRAIN RELIEF ARE DIFFERENT COLORS
W - WHITE
G - GREEN
Y - YELLOW

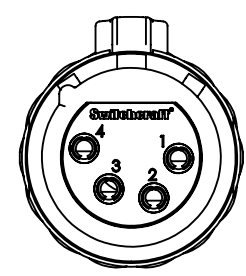
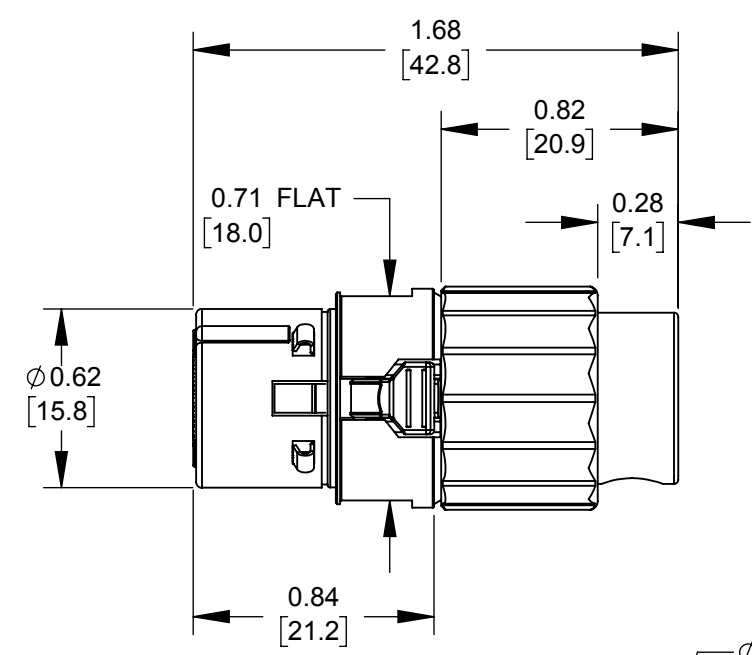
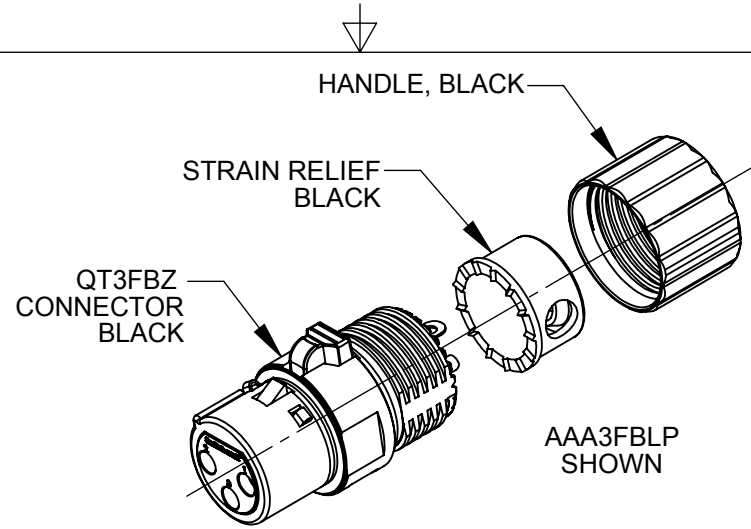

4 PIN

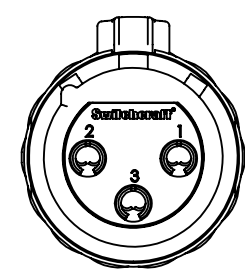

3 PIN

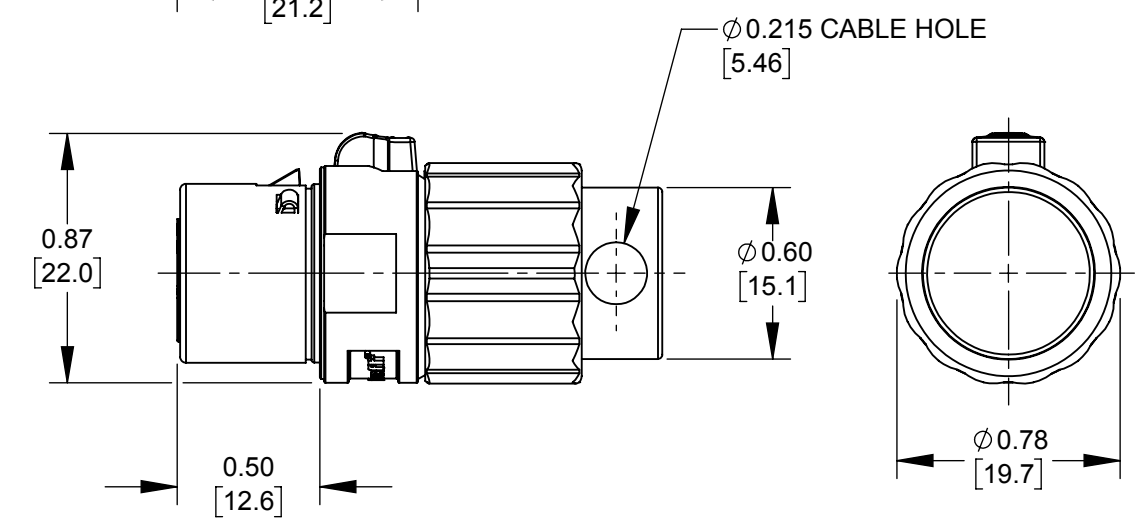

CUSTOMER DRAWING

- NOTES:
- 1. CONNECTOR, HANDLE AND STRAIN RELIEF ARE BULK PACKED, UNASSEMBLED. FOR CONNECTORS IN INDIVIDUAL BAGS ADD "PKG" SUFFIX.
 - 2. MATERIALS:
HANDLE PLASTIC - THERMOPLASTIC
STRAIN RELIEF - THERMOPLASTIC
HOUSING - ZINC ALLOY, NICKEL PLATED OR BLACK
INSULATOR - THERMOPLASTIC, GREEN OR BLACK
GROUND TERMINAL - SPECIAL COPPER ALLOY
CONTACT PINS - SPECIAL COPPER ALLOY, SILVER PLATED OR GOLD PLATED
 - 3. THESE PRODUCTS ARE RoHS COMPLIANT.

REV	ECO NUMBER	DATE	BY	APVD
C	28282	5/5/20	TJK	TJK
B	28078	9-21-18	TJK	TJK
A	28044	07-06-18	PC	TJK
REVISIONS				

☆ STAR SYMBOL DENOTES CRITICAL DIMENSION

UNLESS OTHERWISE SPECIFIED

- 1. ALL DIMENSIONS IN INCHES
- TWO PLACE DECIMALS ±0.01
- THREE PLACE DECIMALS ±0.005
- ANGLES ±1°
- ALL DIA. CONCENTRIC WITHIN 0.005 T.I.R.

- 2. FEATURES ON THE SAME CENTERLINE MUST BE ALIGNED WITHIN ±0.002

- 3. REMOVE ALL BURRS

DO NOT SCALE DRAWING

THIS DRAWING DESCRIBES A DESIGN CONSIDERED PROPRIETARY IN NATURE, DEVELOPED AND MANUFACTURED BY SWITCHCRAFT INC. AND IS RELEASED ON A CONFIDENTIAL BASIS FOR IDENTIFICATION PURPOSES ONLY.									
SIZE	WIDTH	MULT	LBS/M	TEMPER					
FINISH					MATERIAL				
SPEC No.					SPEC No.				
FIRST USED ON					SCALE 1.5:1				
DATE DRAWN	BY	CHKD	APVD						
12-13-17	SRC	SRC	SRC						
			12-13-17						
NAME FEMALE XLR, LOW PROFILE, RIGHT ANGLE, RoHS					PART No. AAA_F_LP_SERIES				
					REV C				

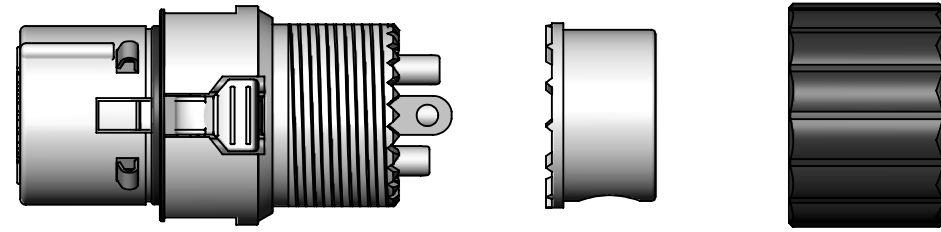

SEE NOTE 1

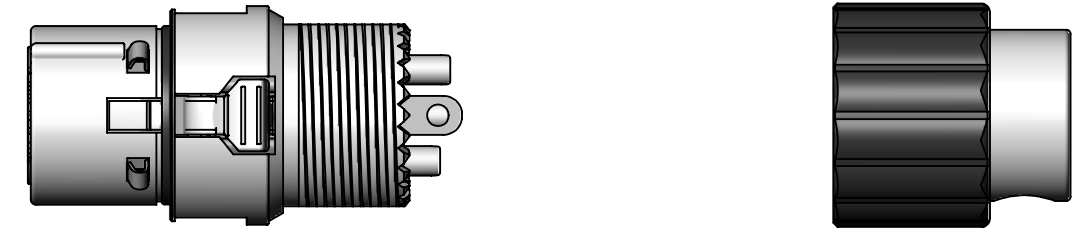

SEE NOTE 2

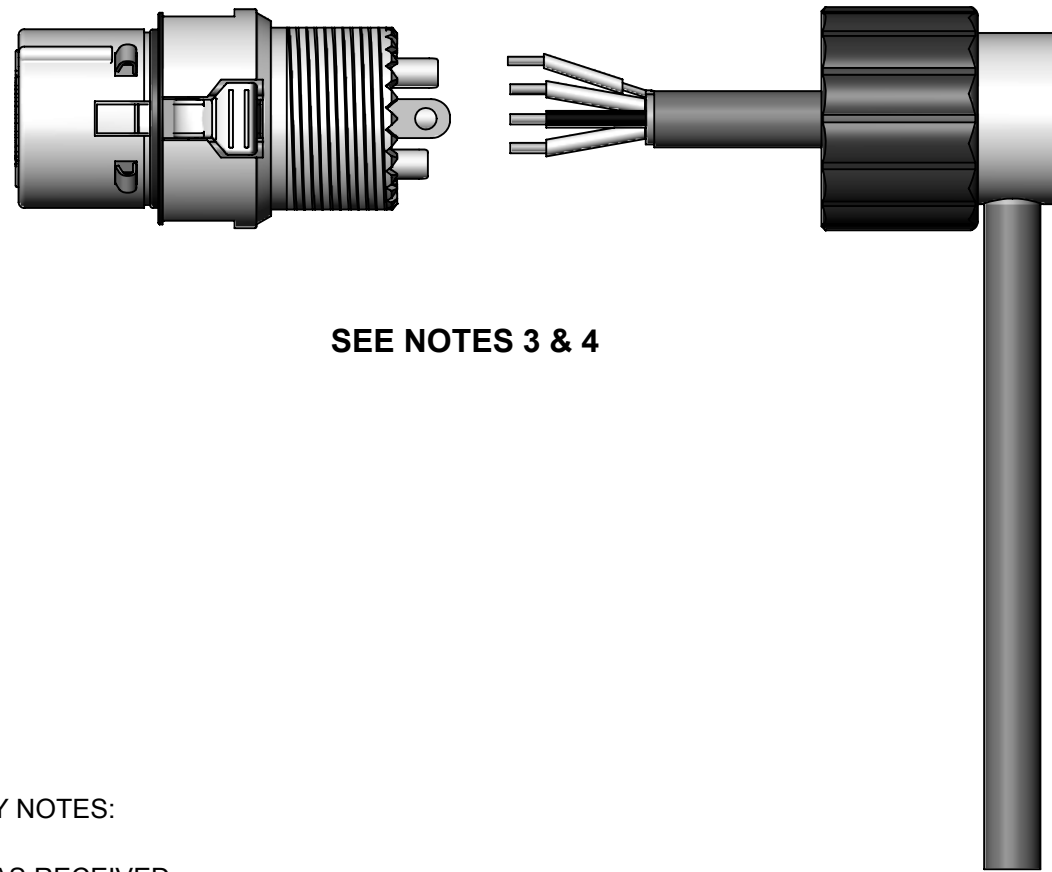

SEE NOTES 3 & 4

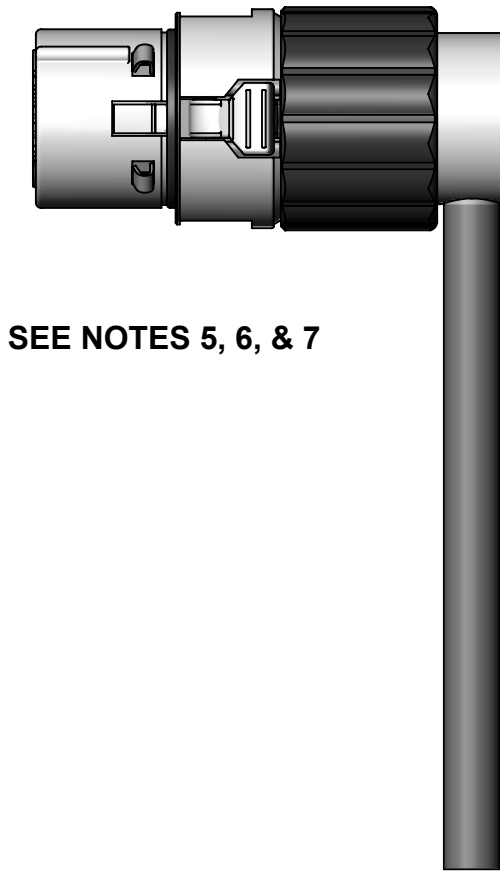

SEE NOTES 5, 6, & 7

ASSEMBLY NOTES:

1. PARTS AS RECEIVED.
2. PUSH STRAIN RELIEF INTO HANDLE AS SHOWN.
3. FEED CABLE THROUGH HOLE IN STRAIN RELIEF.
(3 CONDUCTOR 24 OR 26 GA. WITH OR WITHOUT SHIELD 0.145 TO 0.205 O.D.)
4. STRIP WIRES MINIMUM LENGTH AS NECESSARY (TWIST AND INSULATE SHIELD IF NECESSARY).
5. SOLDER WIRES TO CONTACT PINS AND GROUND TERMINAL.
6. PUSH HANDLE AND STRAIN RELIEF UP TO CONNECTOR THREAD.
TAKE CARE TO ORIENTATE THE WIRE EXIT AREA TO YOUR LIKEABLE POSITION.
7. CAREFULLY SCREW THE HANDLE ONTO THE CONNECTOR UNTIL TIGHT.

CUSTOMER DRAWING

SCALE 1.5:1	Switchcraft [®]	
DATE DRAWN 5-24-18		
DRAWN BY SRC	PART No. AAA_F_LP_SERIES	REV C