



Figure similar

Enclosed soft starter, Controller 3RW44436BC34, Std. duty rating 125Hp @460V, Std. duty current rating 180A, Control voltage 115 AC, Non-combination type, Enclosure NEMA type 1, Indoor general purpose use

product brand name	Class 73
design of the product	Enclosed soft starter
special product feature	Control transformer, built-in overload relay and bypass contactor included.
General technical data	
weight [lb]	116 lb
Height x Width x Depth [in]	36 × 22 × 20 in
touch protection against electrical shock	NA for enclosed products
installation altitude [ft] at height above sea level maximum	6560 ft
ambient temperature [°F]	
• during storage	-22 ... +149 °F
• during operation	-4 ... +104 °F
ambient temperature	
• during storage	-30 ... +65 °C
• during operation	-20 ... +40 °C
country of origin	USA
Power and control electronics	
manufacturer's article number of soft starter	3RW44436BC34
number of poles for main current circuit	3
design of power semiconductors (thyristors) for soft starter control	3 controlled phases
operating range factor supply voltage rated value	0.85 ... 1.1
operating range factor of control voltage rated value	0.85 ... 1.1
operating condition for standard duty	Class 10 standard duty (350% of motor FLA for 10 seconds)
operating condition for severe duty	Class 20 severe duty (350% of motor FLA for 20 seconds)
Features and functions	
ramp-up (soft starting)/ramp-down (soft stop)	Yes
starting voltage [%]	20 ... 100 %
stopping voltage [%]	20 ... 100 %
voltage ramp	Yes
ramp-up time	1 ... 360 s
ramp-down time	1 ... 360 s
torque control	Yes
starting torque [%]	20 ... 100 %
stopping torque [%]	20 ... 100 %
torque limitation [%]	20 ... 200 %
ramp time of torque	1 ... 360 s
adjustable current limitation	Yes
creep speed in both directions of rotation	Yes

pump ramp down	Yes
integrated bypass contact system	Yes
external isolation contactor	No
intrinsic device protection	Yes
overload protection	Yes
trip class	CLASS 5 / 10 / 15 / 20 / 30
reset function	Manual and automatic
thermistor motor protection	Yes
inside-delta circuit	Yes
breakaway pulse	Yes
DC braking	Yes
combined braking	Yes
motor heating	Yes
configuration of control input 1	Factory set as START MOTOR
configuration of control input 2	programmable
configuration of control input 3	programmable
configuration of control input 4	Factory set as TRIP RESET
configuration of relay output 1	Factory set as ON-TIME MOTOR
configuration of relay output 2	programmable
configuration of relay output 3	programmable
configuration of relay output 4	Factory set as GROUP ERROR
display version	Graphic display
operating measured value display	Yes
product extension optional human machine interface module	Yes
type of communication optional	With optional Profibus or Profinet
error logbook	Yes
event list	Yes
slave pointer function	Yes
trace function	Yes
number of parameter sets	3
engineering software (Soft Starter ES)	Yes
disconnecter functionality	No
Contactor	
size of contactor	NA
Coil	
type of voltage of the control supply voltage	AC
control supply voltage	
• at AC at 50 Hz rated value	115 V
• at AC at 60 Hz rated value	115 V
Enclosure	
degree of protection NEMA rating	1
degree of protection NEMA rating of the enclosure	NEMA Type 1
design of the housing	indoors, usable on a general basis
type of cooling	None
Mounting/wiring	
mounting position	Vertical
fastening method	Surface mounting and installation
wire length between motor starter and motor maximum	500 m
type of electrical connection for supply voltage line-side	Box lug
tightening torque [lbf-in] for supply	180 ... 195 lbf-in
type of connectable conductor cross-sections at line-side at AWG cables single or multi-stranded	3/0 AWG ... 600 MCM (front only) or 250 ... 500 MCM (back only) or 2x 2/0 AWG ... 2x 500 MCM (both front & back)
temperature of the conductor for supply maximum permissible	75 °C
material of the conductor for supply	AL or CU
type of electrical connection for load-side outgoing feeder	Box lug
tightening torque [lbf-in] for load-side outgoing feeder	180 ... 195 lbf-in
type of connectable conductor cross-sections at AWG cables for load-side outgoing feeder single or multi-stranded	3/0 ... 600 kcmil (front only) or 250 ... 500 kcmil (back only) or 2x 500 kcmil (both front & back) AWG

temperature of the conductor for load-side outgoing feeder maximum permissible	75 °C
material of the conductor for load-side outgoing feeder	CU
type of electrical connection for auxiliary and control circuit	screw-type terminals
tightening torque [lbf-in] for auxiliary and control contacts with screw-type terminals	7 ... 10 lbf-in
temperature of the conductor for auxiliary and control contacts maximum permissible	75 °C
material of the conductor for auxiliary and control contacts	CU

Short-circuit current rating	
design of the fuse link for short-circuit protection of the main circuit required	10kA@600V (Class H or K); 100kA@600V (Class R, J or L)
design of the short-circuit trip	Thermal magnetic circuit breaker
breaking capacity maximum short-circuit current (Icu)	
<ul style="list-style-type: none"> at 240 V at 480 V at 600 V 	100 kA 100 kA 0 kA
certificate of suitability	NEMA ICS 2; UL 508A

Further information

- Industrial Controls - Product Overview (Catalogs, Brochures,...)
www.usa.siemens.com/iccatalog
- Industry Mall (Online ordering system)
<https://mall.industry.siemens.com/mall/en/us/Catalog/product?mlfb=US2:73KT34BFA>
- Service&Support (Manuals, Certificates, Characteristics, FAQs,...)
<https://support.industry.siemens.com/cs/US/en/ps/US2:73KT34BFA>
- Image database (product images, 2D dimension drawings, 3D models, device circuit diagrams, EPLAN macros, ...)
http://www.automation.siemens.com/bilddb/cax_de.aspx?mlfb=US2:73KT34BFA&lang=en
- Certificates/approvals
<https://support.industry.siemens.com/cs/US/en/ps/US2:73KT34BFA/certificate>

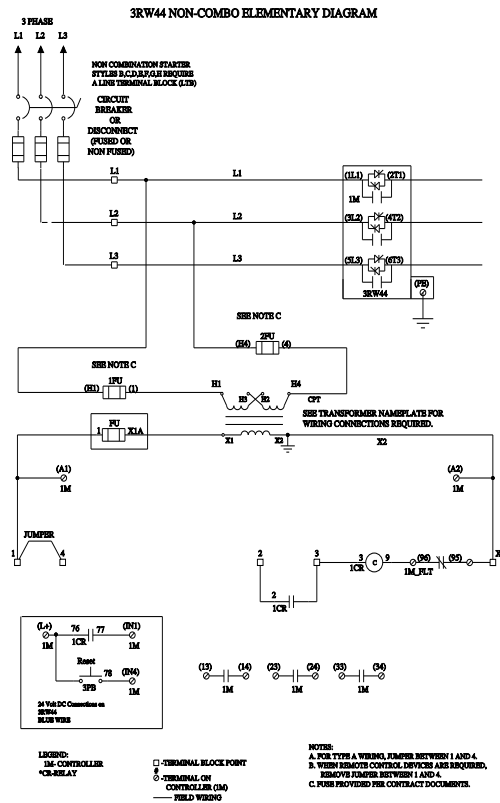

D69015H11

last modified:

1/25/2022