



TAI-SAW TECHNOLOGY CO., LTD.

No. 3, Industrial 2nd Rd., Ping-Chen Industrial District,
Taoyuan, 324, Taiwan, R.O.C.

TEL: 886-3-4690038 FAX: 886-3-4697532

E-mail: tstsales@mail.taisaw.com Web: www.taisaw.com

Product Specifications Approval Sheet

Product Name: SAW Filter 1568MHz SMD 3.0 x 3.0mm(BW=18.322MHz)

TST Parts No.: :TA1584A

Customer Parts No.: _____

Company: _____
Division: _____
Approved by : _____
Date: _____

Checked by: _____ Andy Yu 

Approval by: _____ Bob Chau 

Date: _____ 2015/6/17

1. Customer signed back is required before TST can proceed with sample build and receive orders.
2. Orders received without customer signed back will be regarded as agreement on the specifications.
3. Any specifications changes must be approved upon by both parties and a new revision of specifications shall be released to reflect the changes.



TAI-SAW TECHNOLOGY CO., LTD.

No. 3, Industrial 2nd Rd., Ping-Chen Industrial District,
Taoyuan, 324, Taiwan, R.O.C.

TEL: 886-3-4690038 FAX: 886-3-4697532

E-mail: tstsales@mail.taisaw.com Web: www.taisaw.com

SAW Filter 1568MHz SMD 3.0 x 3.0mm(BW=18.322MHz)

MODEL NO.: TA1584A

REV. NO : 3.0

A. MAXIMUM RATING:

1. Input Power Level: 10 dB_m
2. DC voltage: 0 V
3. Operating Temperature: -40°C to +85°C
4. Storage Temperature: -40°C to +105°C
5. MSL 1

RoHS Compliant
Lead free
Lead-free soldering

Electrostatic Sensitive Device

B. ELECTRICAL CHARACTERISTICS:

Item		Min.	Typ.	Max.	
Center frequency	F_c	-	1568	-	
Insertion loss within 1559.098 ~1563.098 MHz	IL	-	1.1	2.0	
Insertion loss within 1573.420 ~1577.420 MHz	IL	-	1.3	2.2	
Amplitude ripple (p-p) within 1559.098 ~ 1577.420 MHz		-	0.3	1.2	
Group delay ripple within 1559.098 ~ 1577.420 MHz			4	40	
Attenuation (Reference level from 0 dB)					
10.000 ~ 820.00	MHz	dB	27	35	-
820.00 ~ 1521.0	MHz	dB	30	35	-
1616.0 ~ 1624.0	MHz	dB	45	59	-
1624.0 ~ 3000.0	MHz	dB	30	38	-
VSWR within 1559.098 ~1577.420	MHz		-	1.45	2.0
Source impedance	Z _s	Ω	-	50	-
Load impedance	Z _L	Ω	-	50	-

C. MEASUREMENT CIRCUIT:

HP Network analyzer

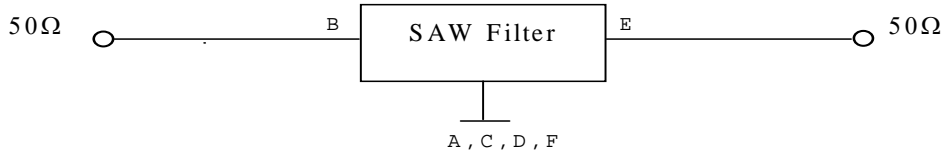

D. OUTLINE DRAWING :

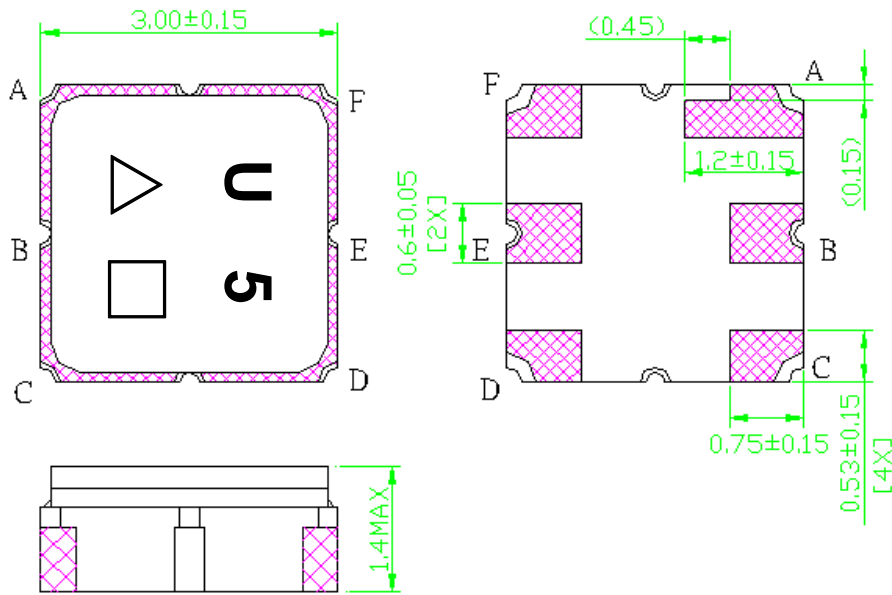

B : Input

E : Output

A、C、D、F : Ground

Unit : mm

△ : Year Code(2012→2,...2019→9)

□ : Date Code(Follow the table from planner each year)

WK01	WK02	WK03	WK04	WK05	WK06	WK07	WK08	WK09	WK10	WK11	WK12	WK13
A	B	C	D	E	F	G	H	I	J	K	L	M
WK14	WK15	WK16	WK17	WK18	WK19	WK20	WK21	WK22	WK23	WK24	WK25	WK26
N	O	P	Q	R	S	T	U	V	W	X	Y	Z
WK27	WK28	WK29	WK30	WK31	WK32	WK33	WK34	WK35	WK36	WK37	WK38	WK39
a	b	c	d	e	f	g	h	i	j	k	l	m
WK40	WK41	WK42	WK43	WK44	WK45	WK46	WK47	WK48	WK49	WK50	WK51	WK52
n	o	p	q	r	s	t	u	v	w	x	y	z

E. PCB Footprint :

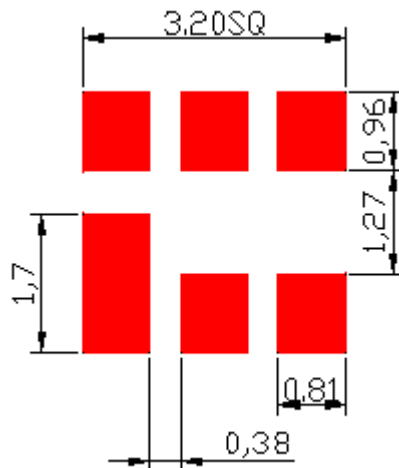

F. Frequency Characteristics :
Transfer function

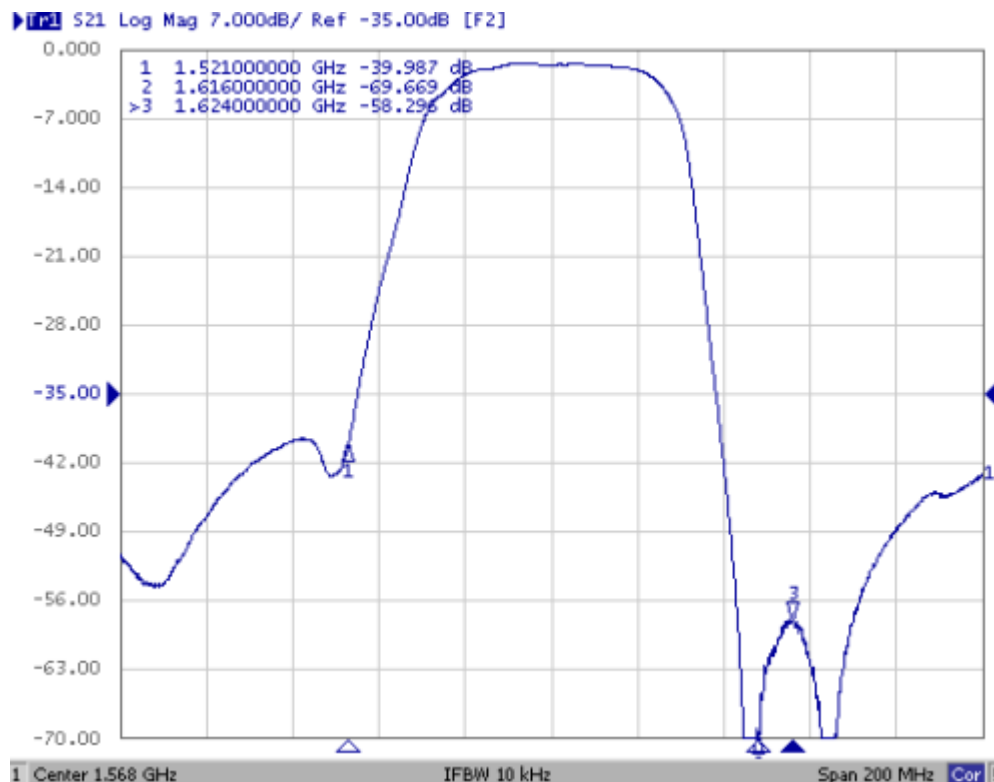
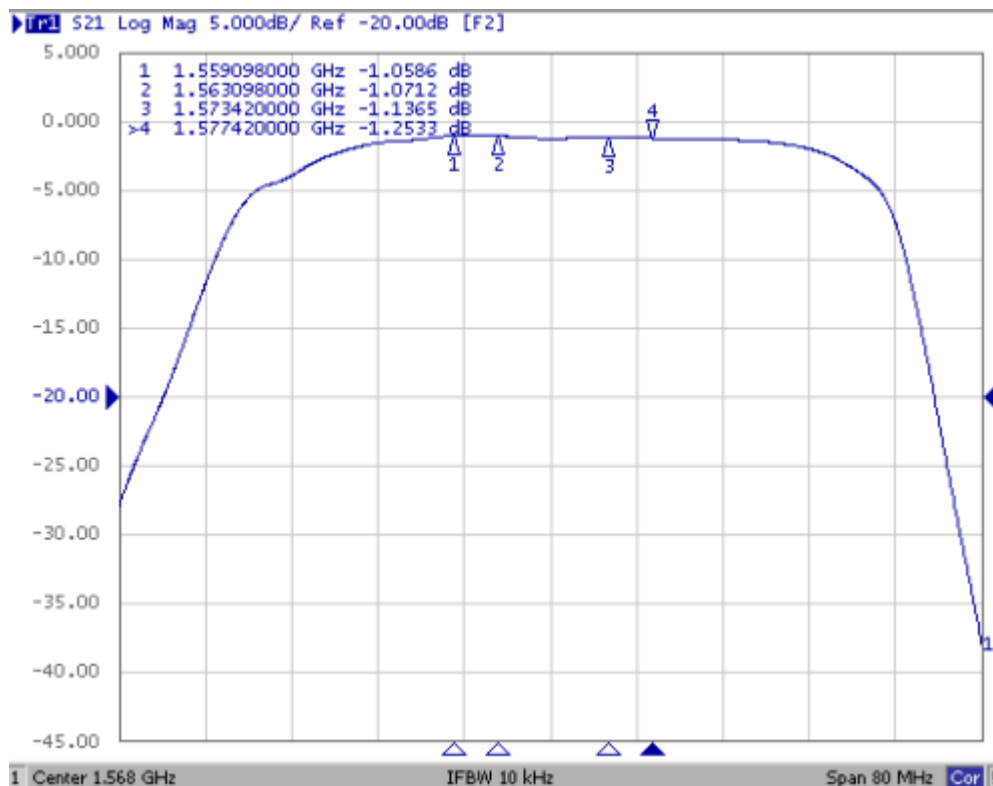

Wide band :

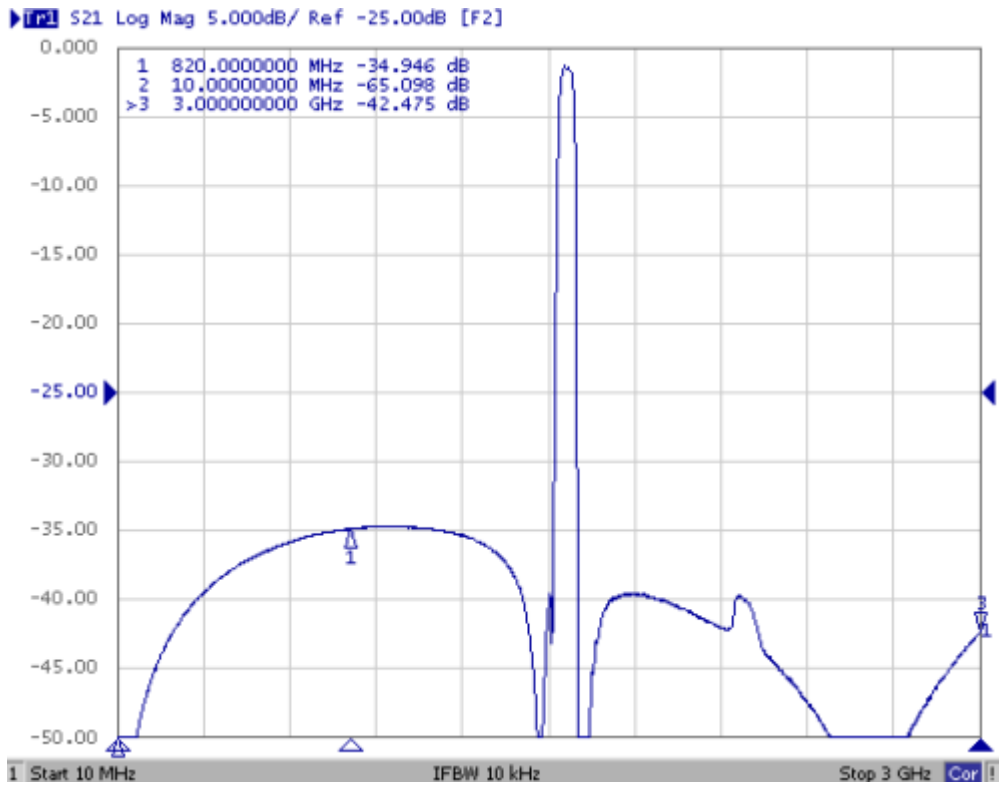

Group delay ripple :

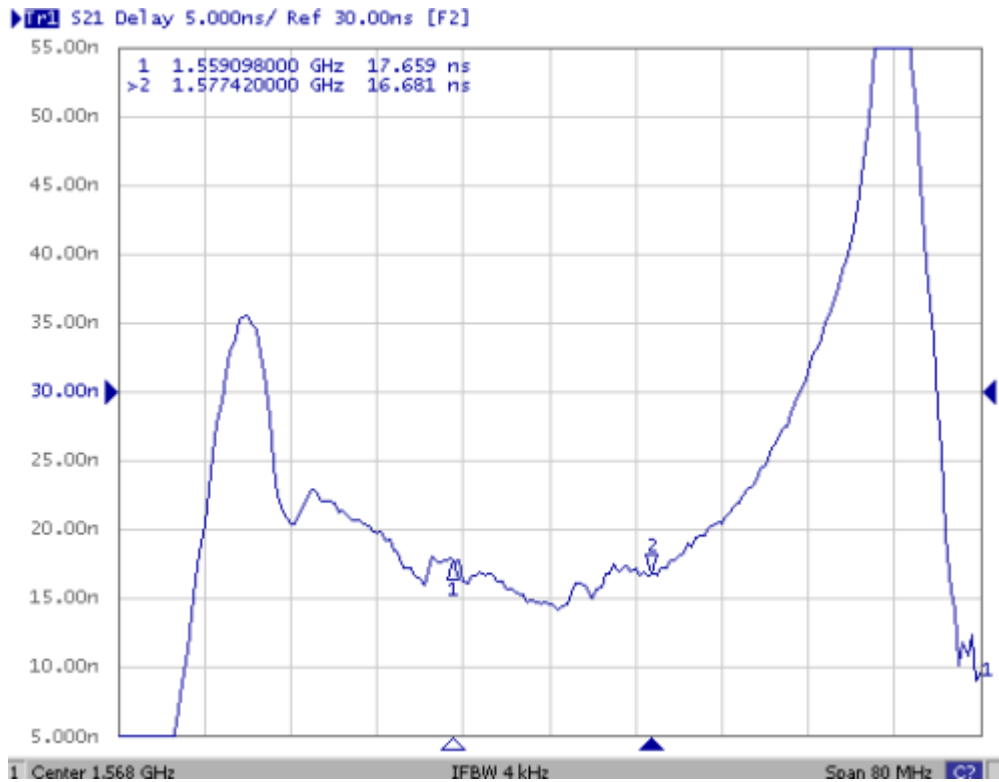

VSWR_S11 :

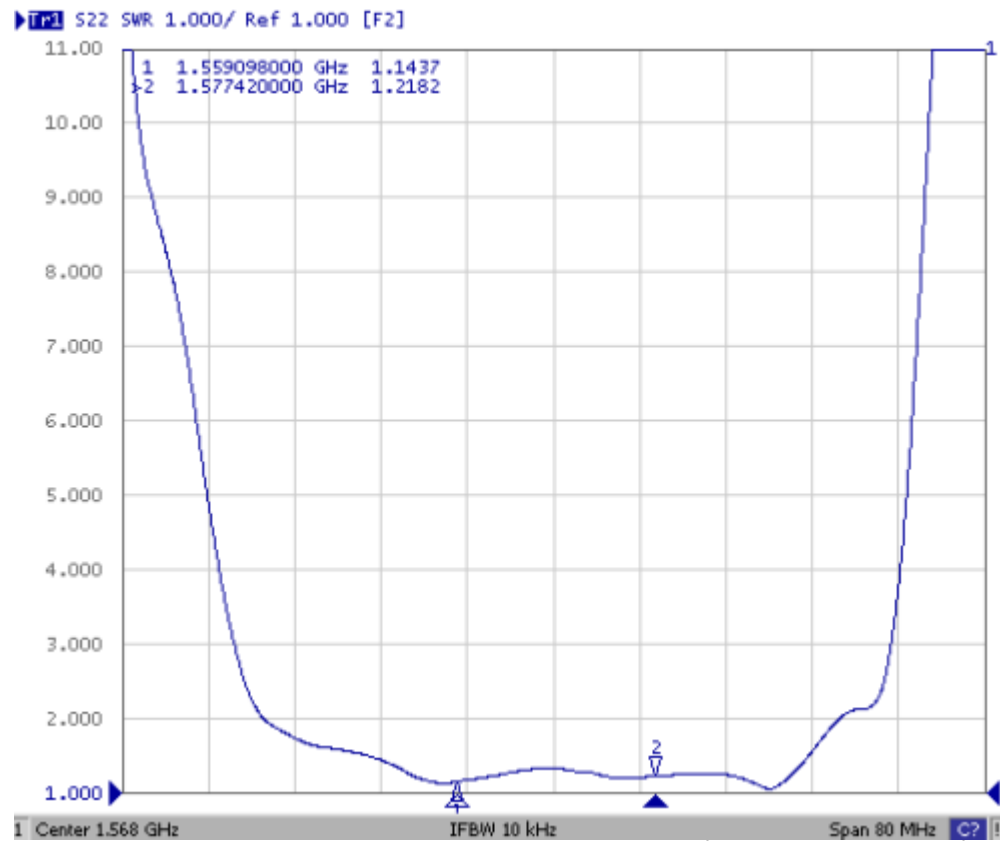
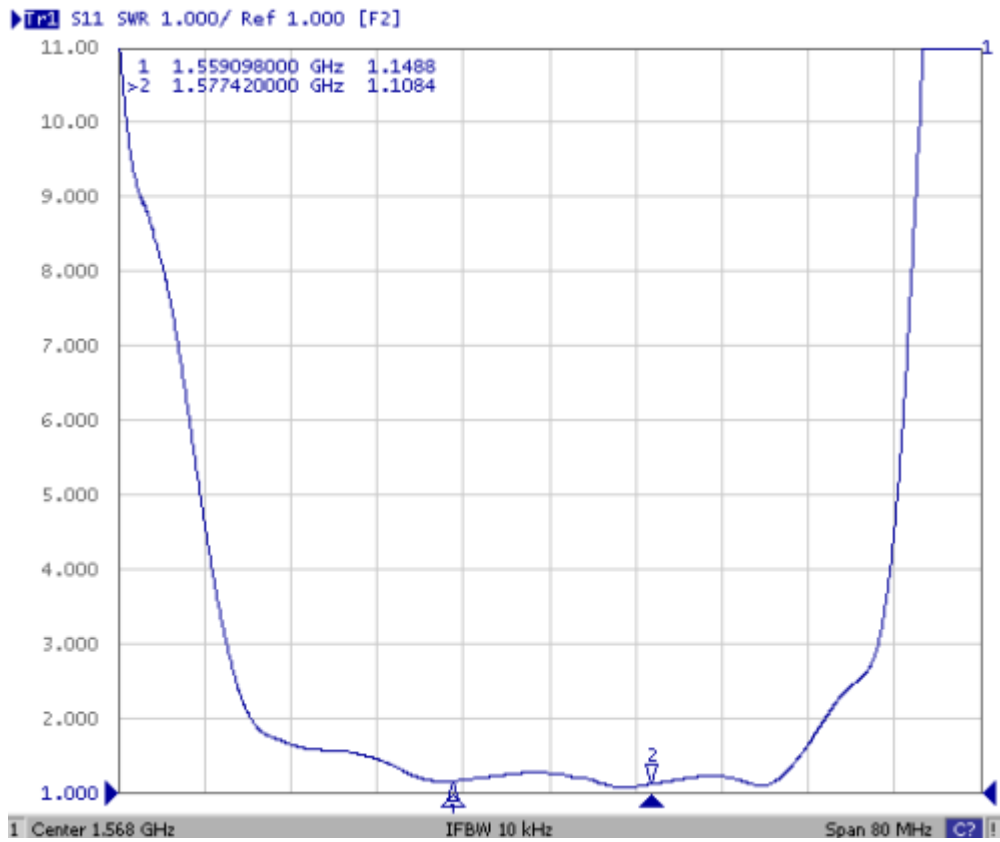

G. PACKING:

1. REEL DIMENSION

(Please refer to FR-75D10 for packing quantity)

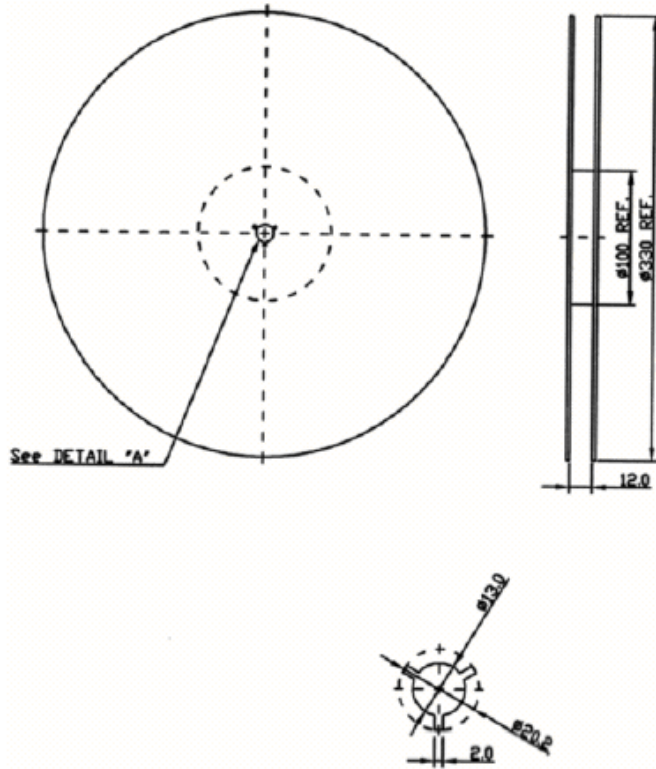

2. TAPE DIMENSION

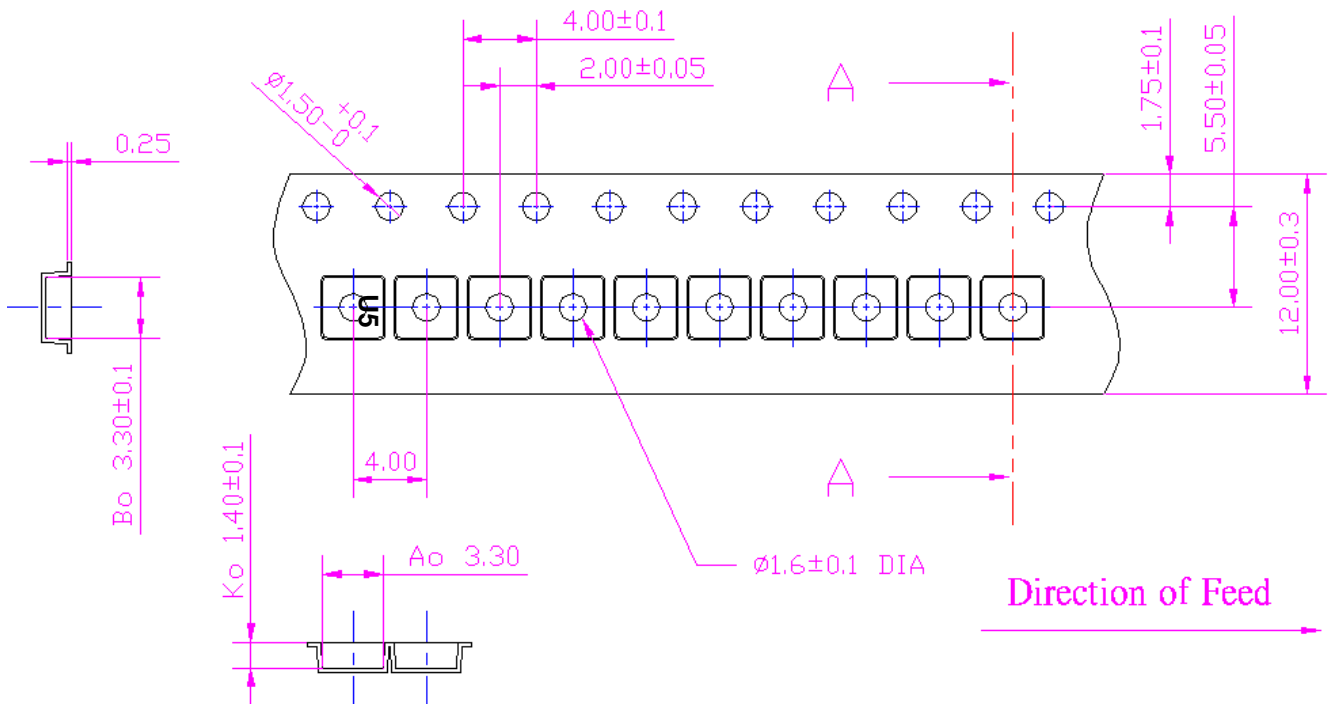

H. RECOMMENDED REFLOW PROFILE:

